

EDR-3000-2A0AA

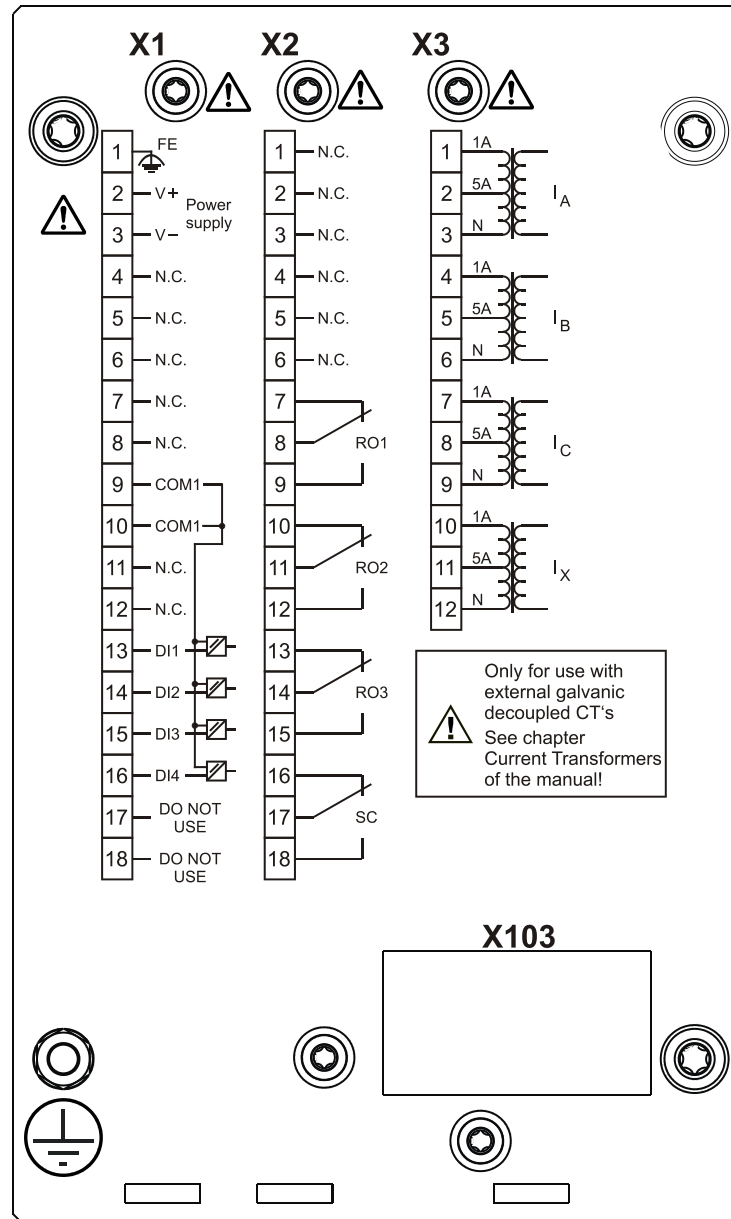

EDR-3000-2A0AB

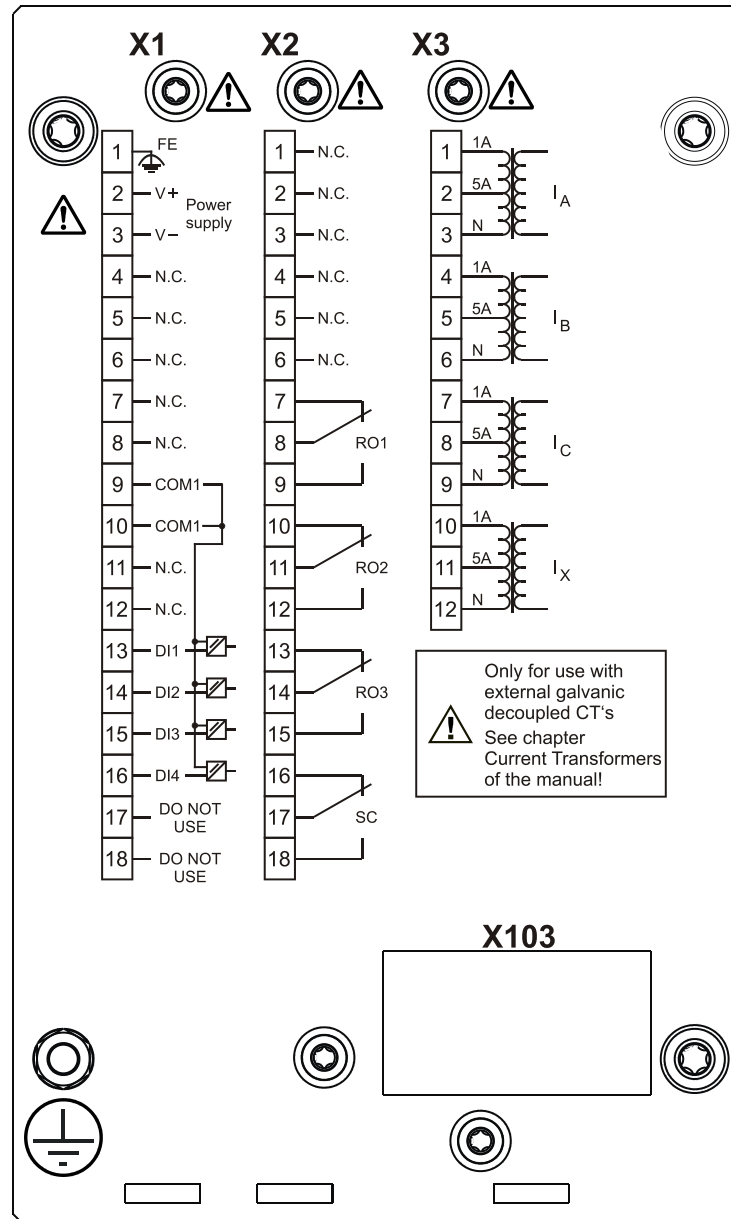

EDR-3000-2A0BA

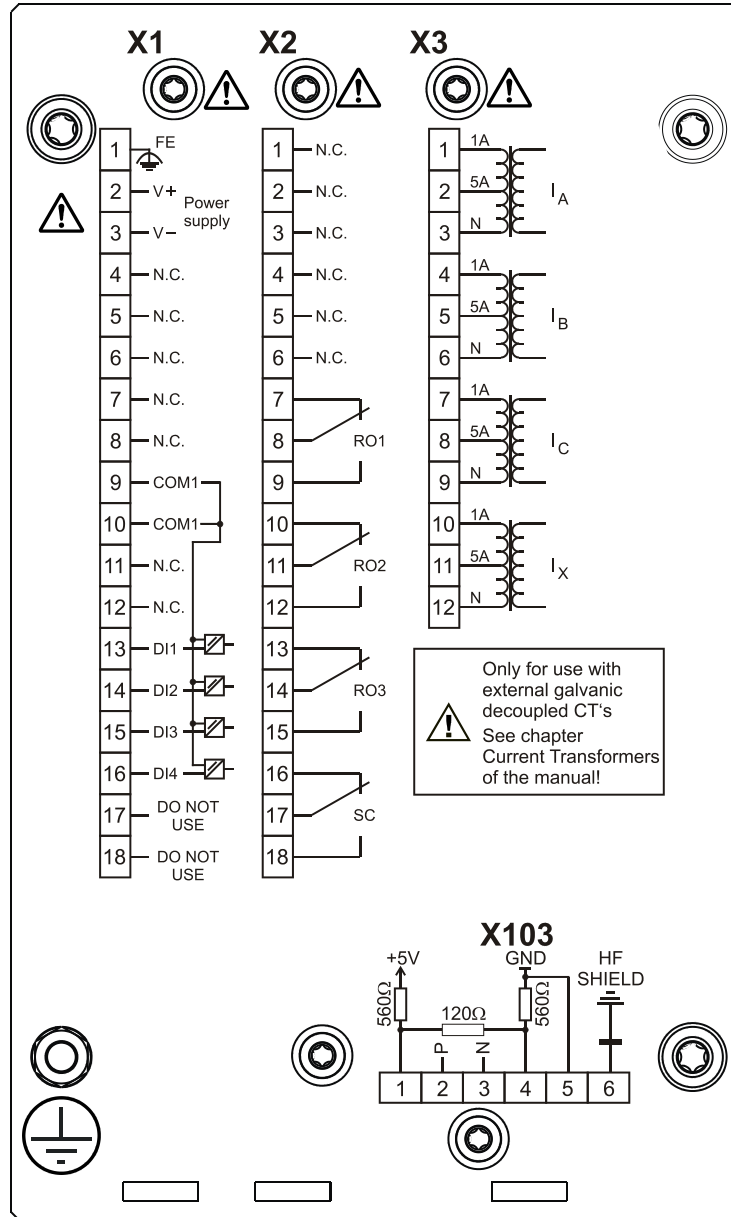

EDR-3000-2A0BB

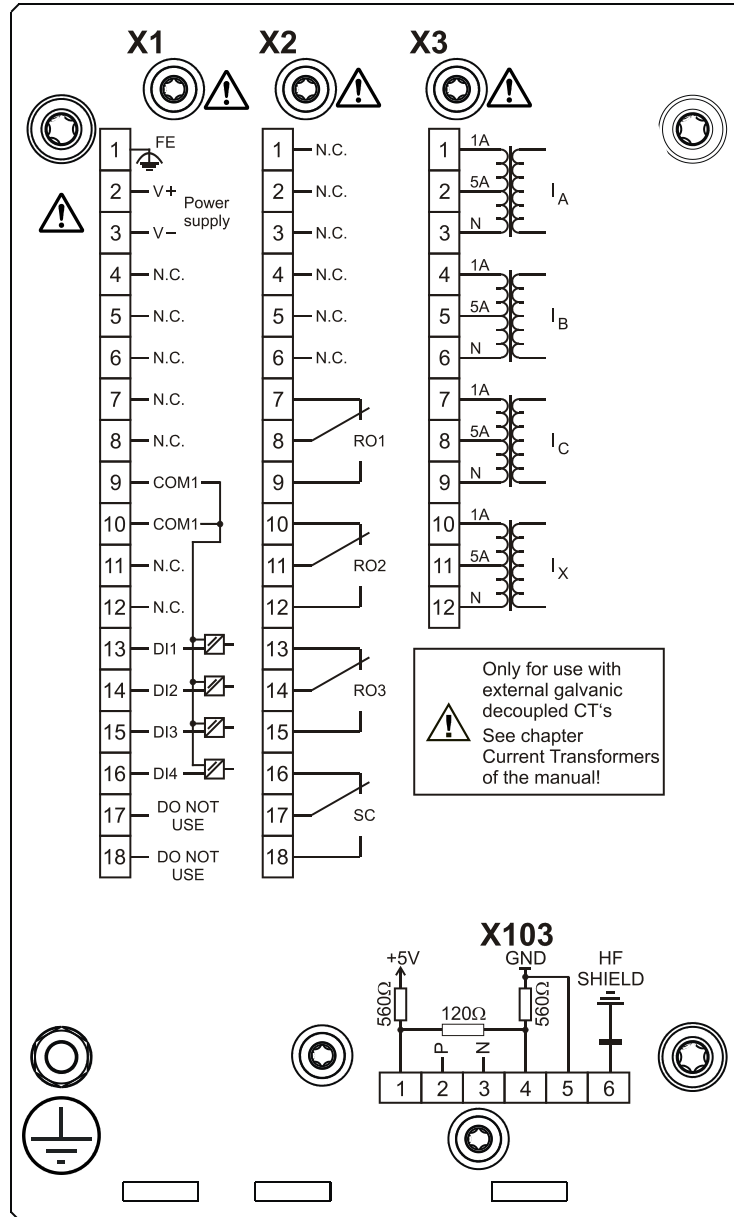

EDR-3000-2A0CA

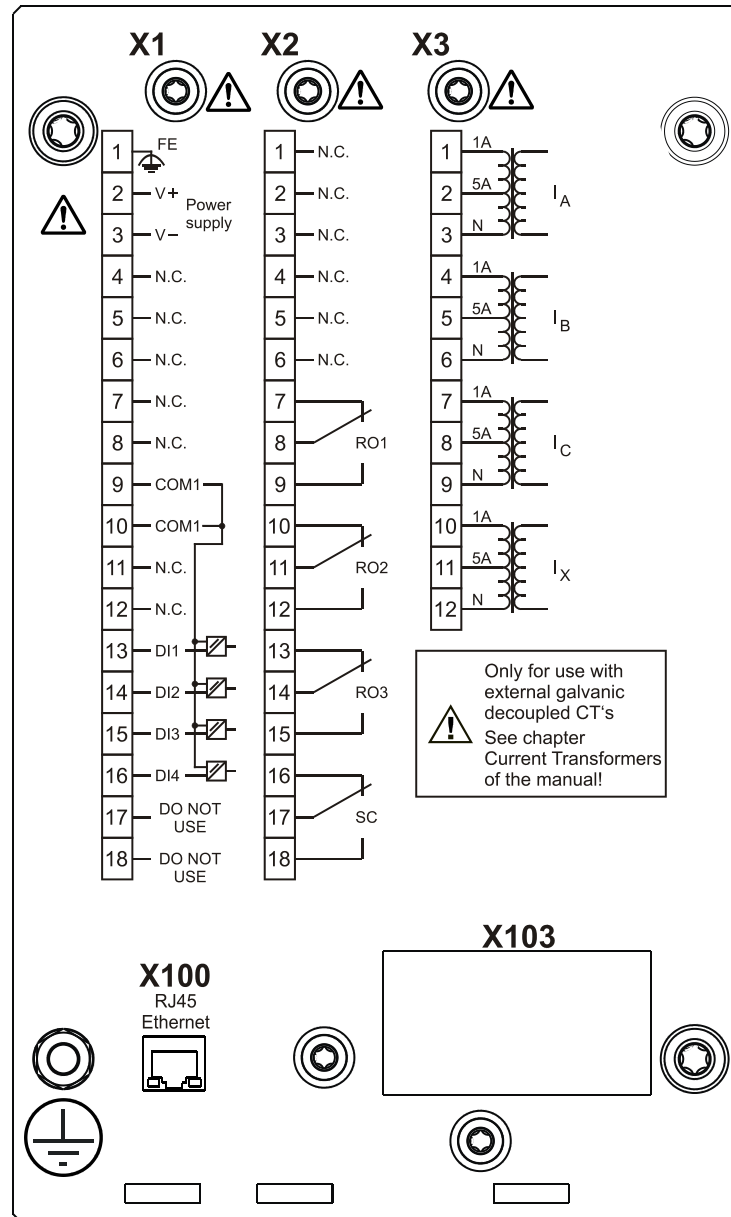

EDR-3000-2A0CB

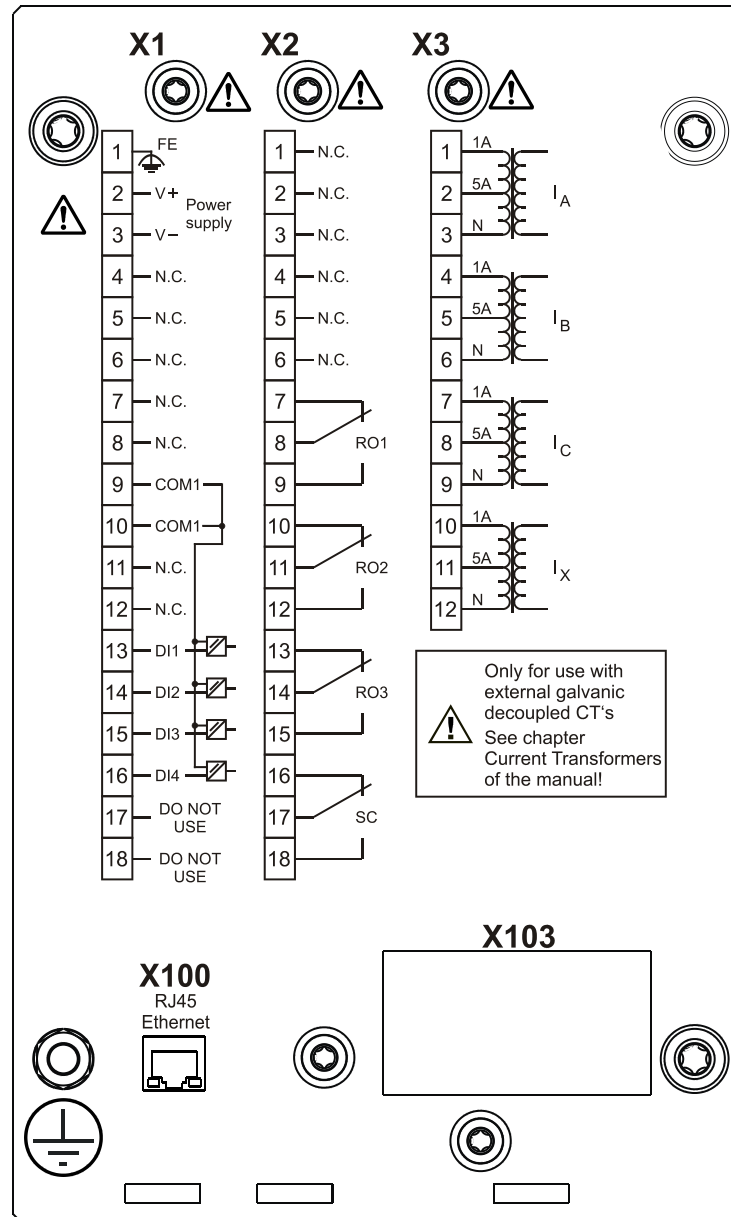

EDR-3000-2A0DA

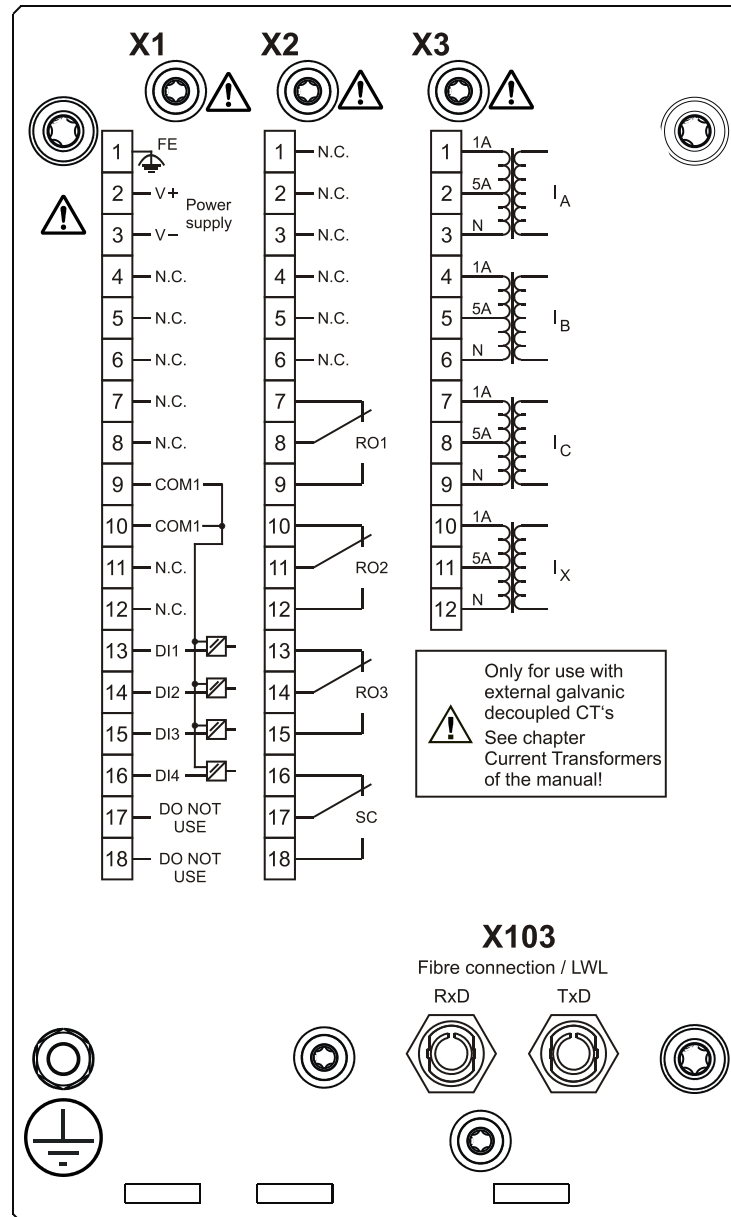

EDR-3000-2A0DB

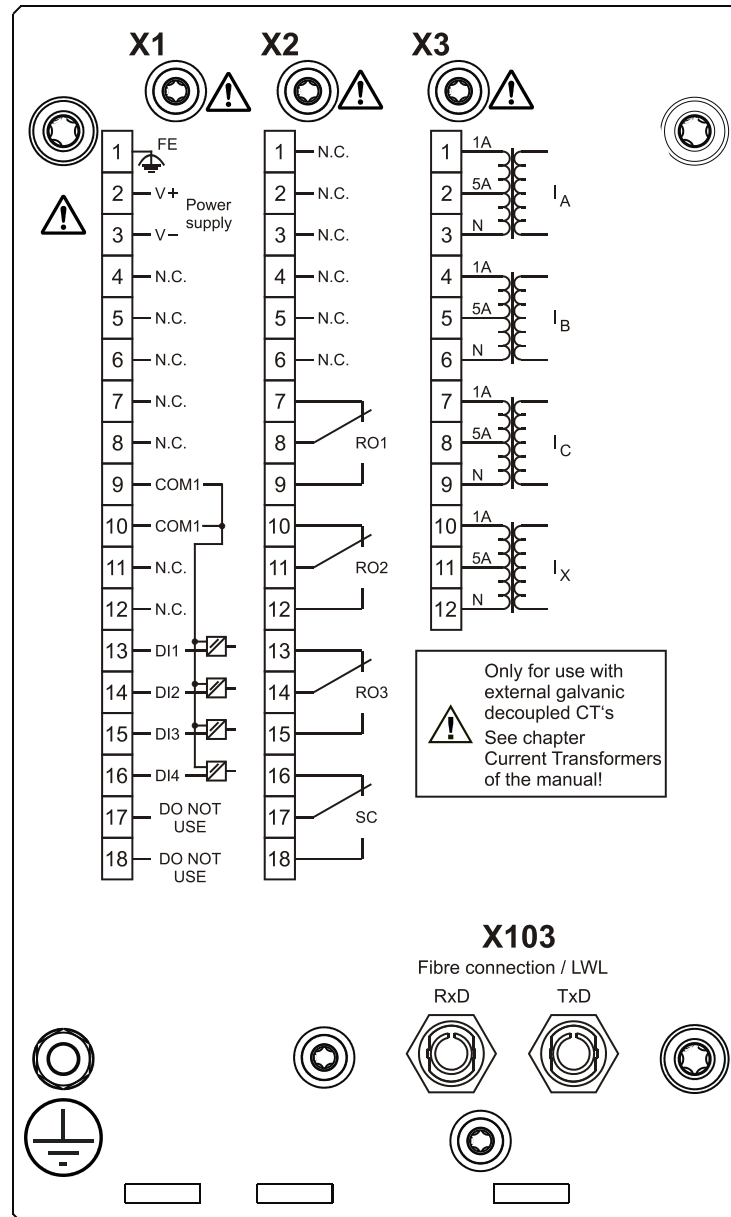

EDR-3000-2A0EA

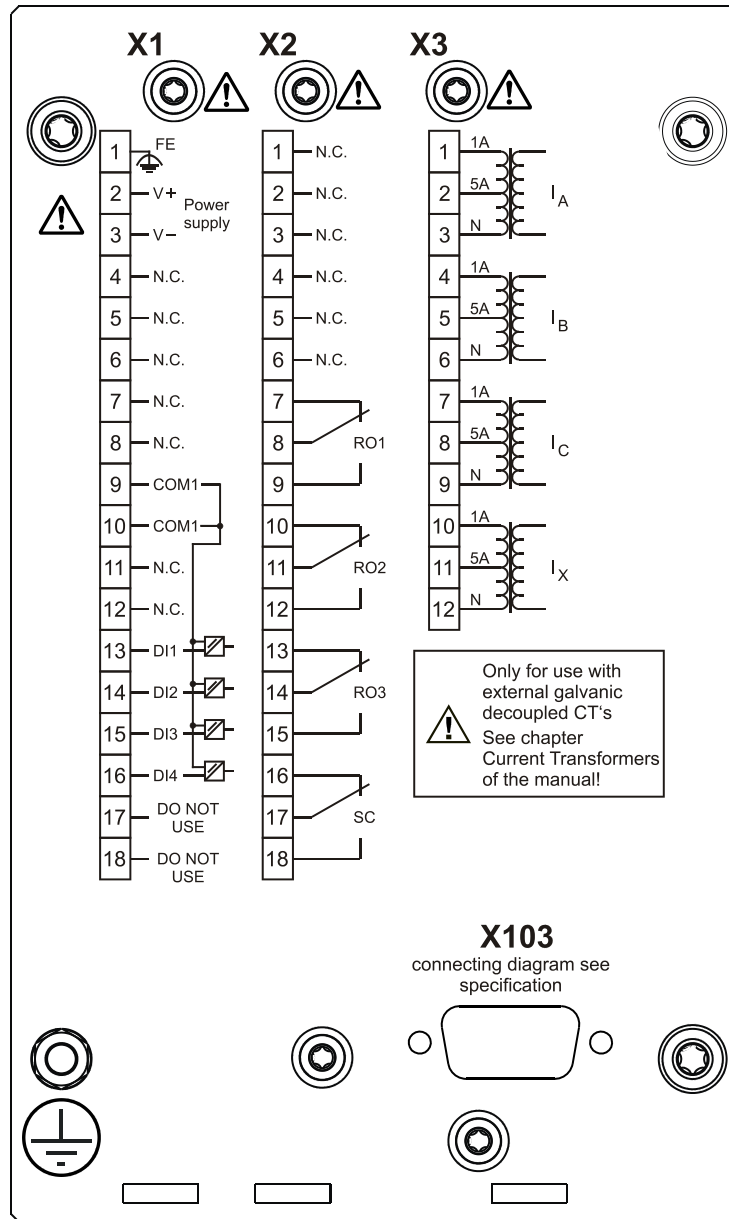

EDR-3000-2A0EB

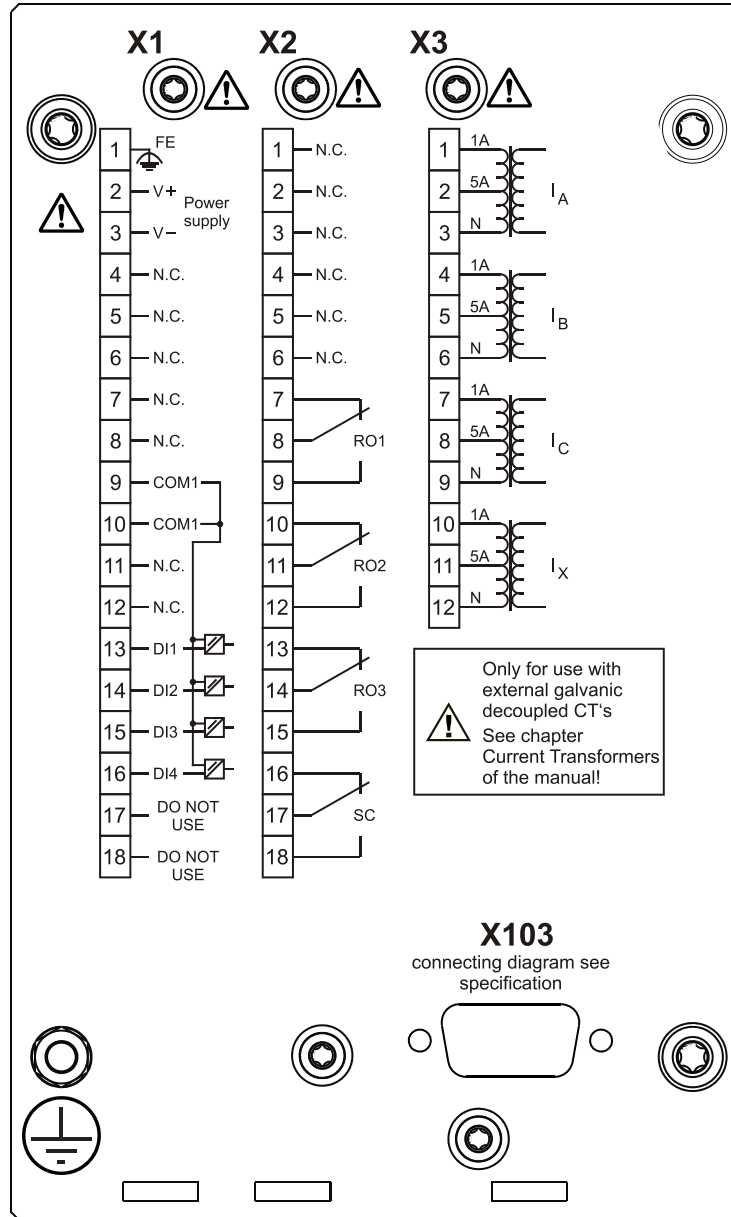

EDR-3000-2A0FA

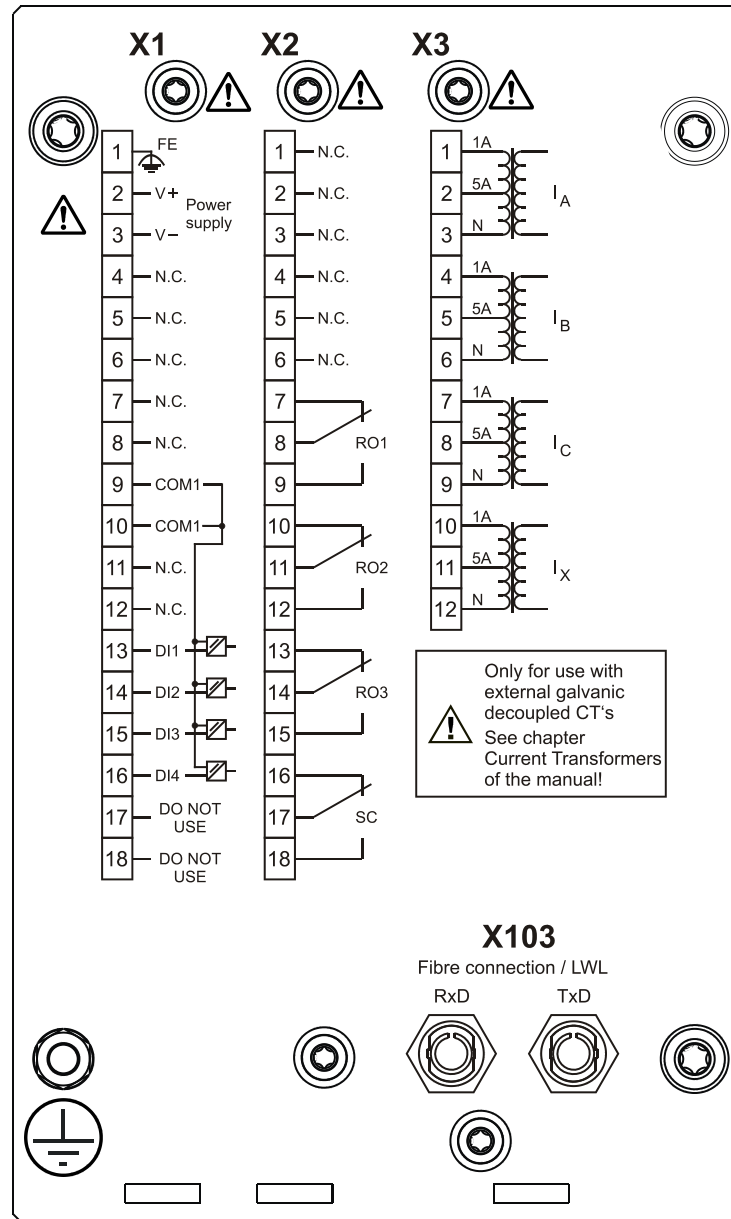

EDR-3000-2A0FB

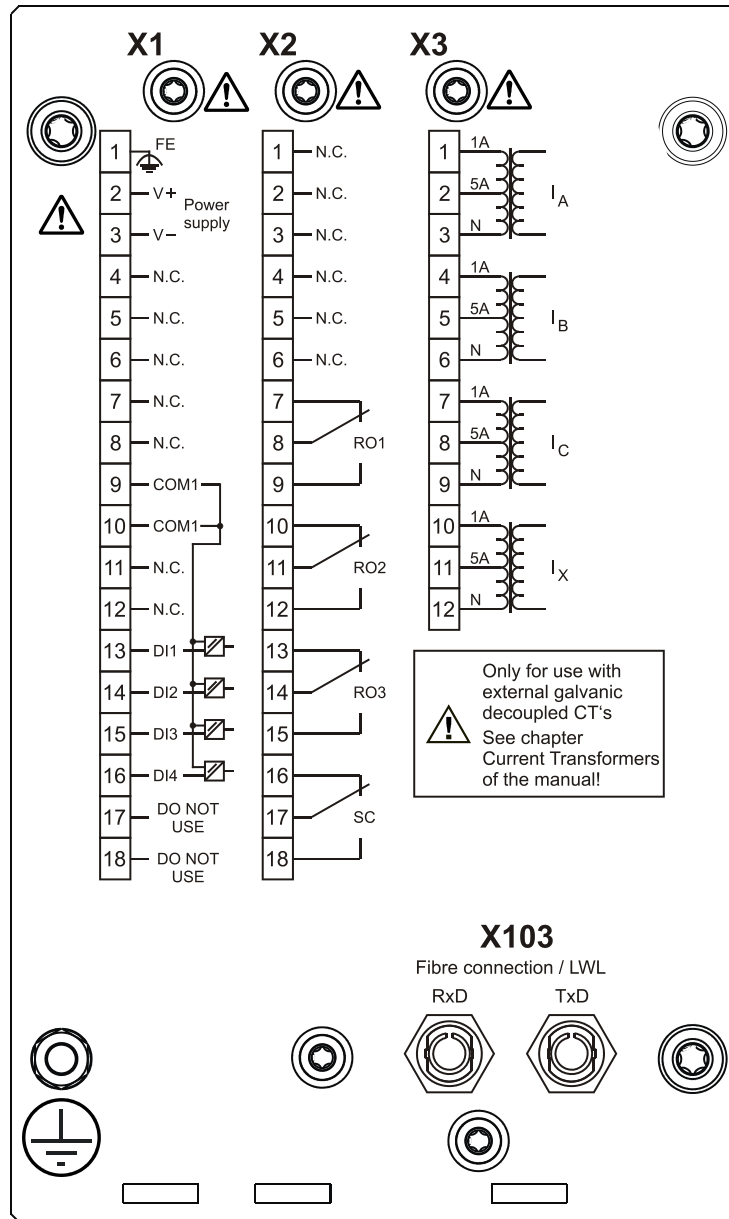

EDR-3000-2A0GA

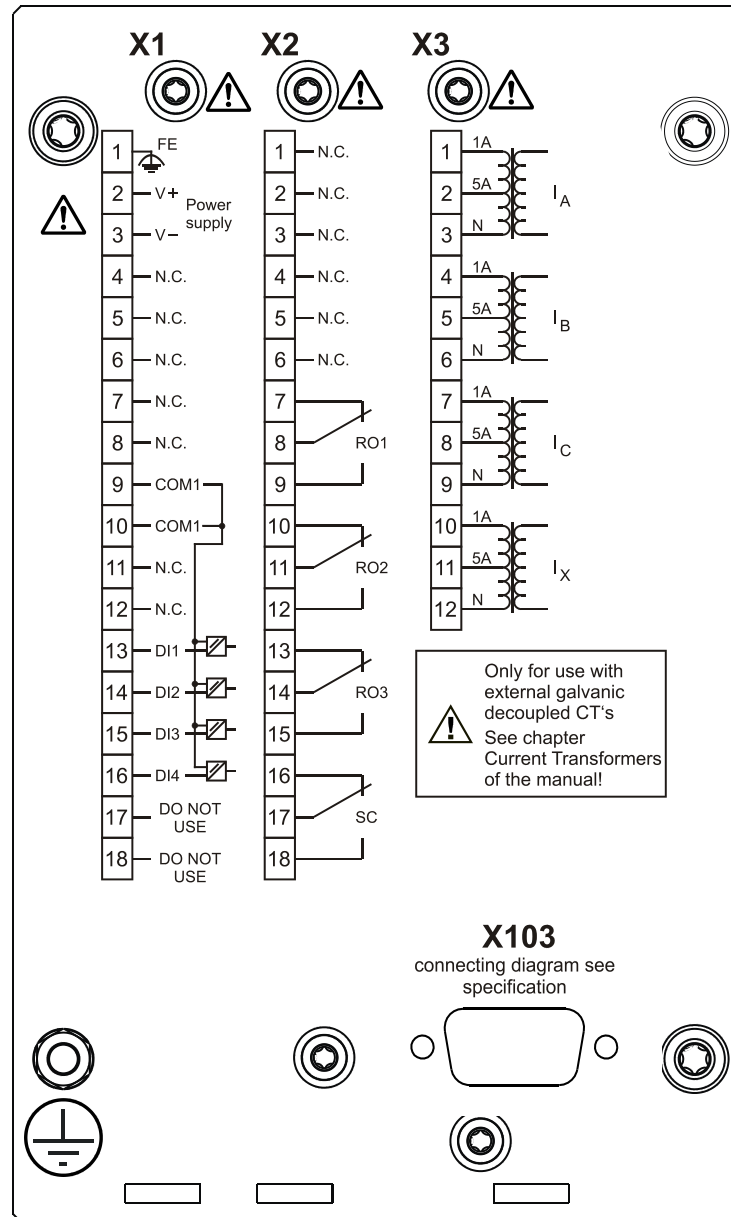

EDR-3000-2A0GB

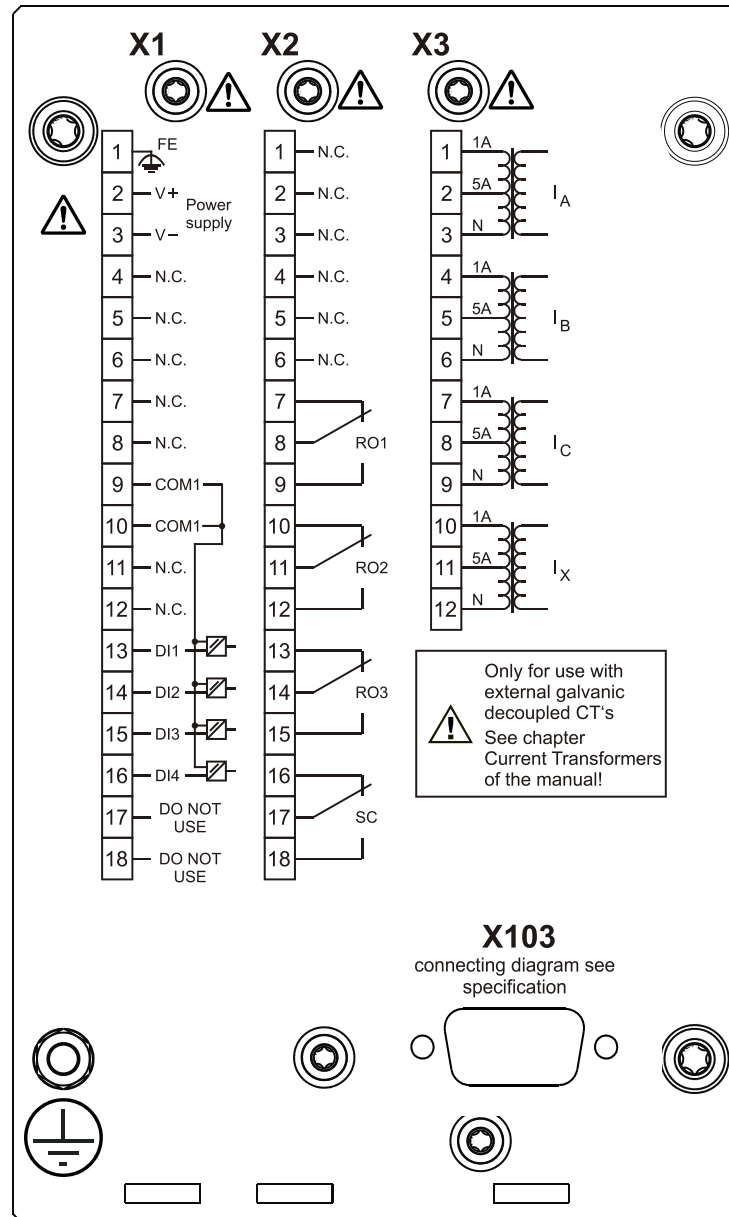

EDR-3000-2A0HA

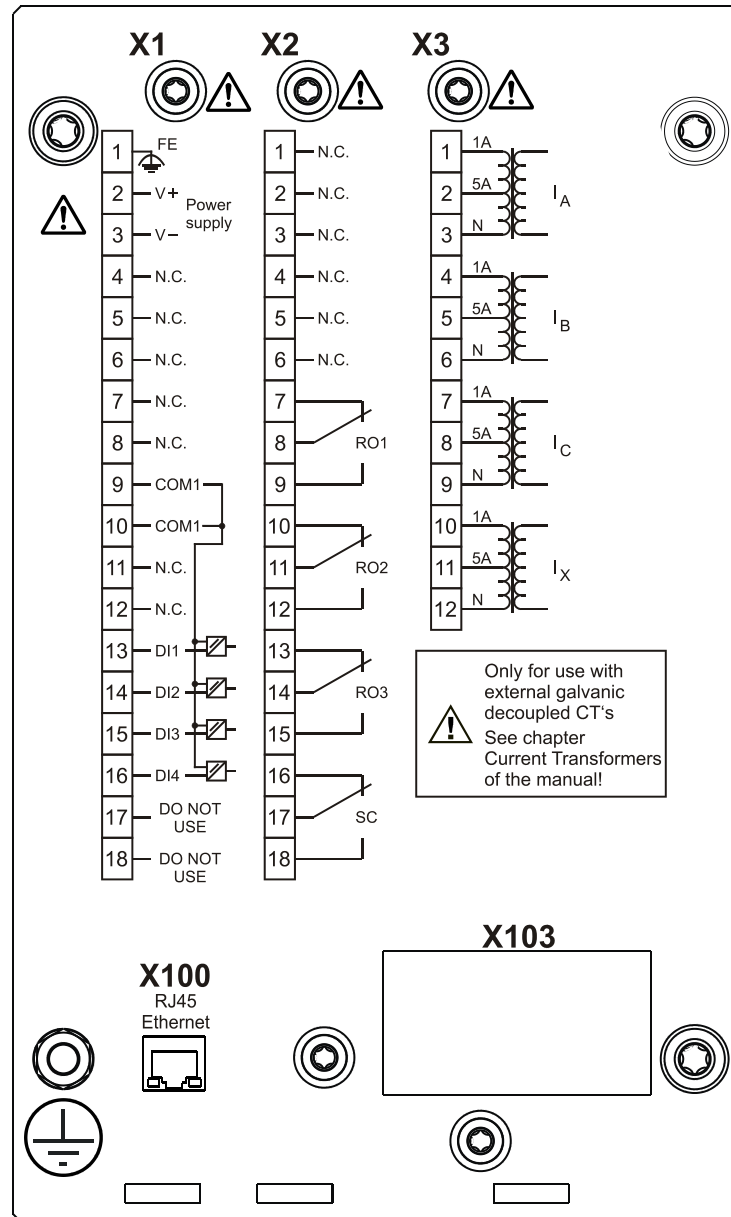

EDR-3000-2A0HB

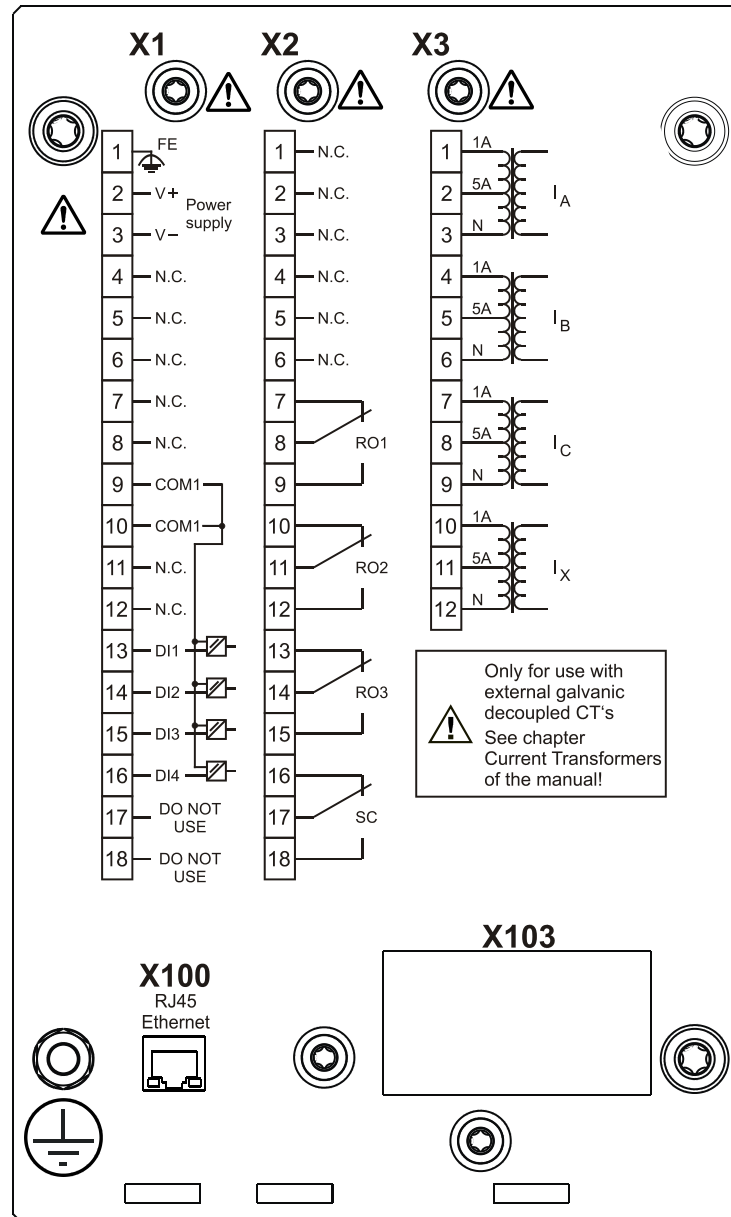

EDR-3000-2A01A

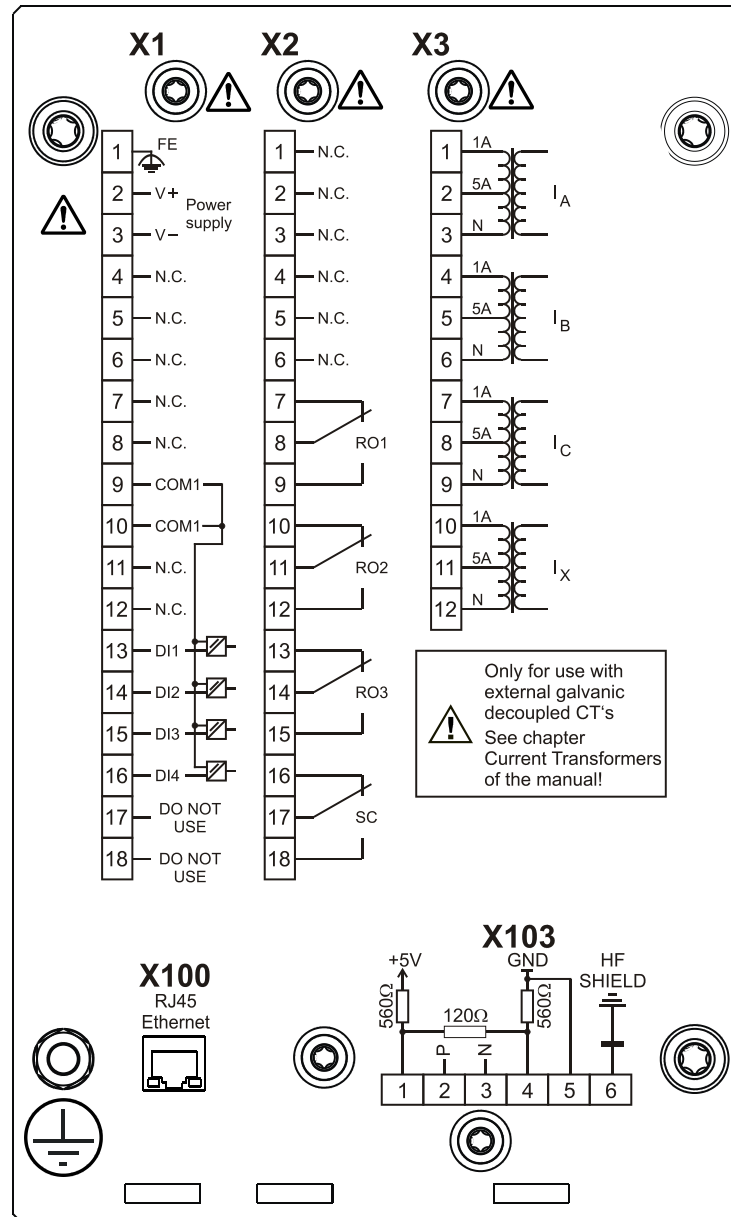

EDR-3000-2A01B

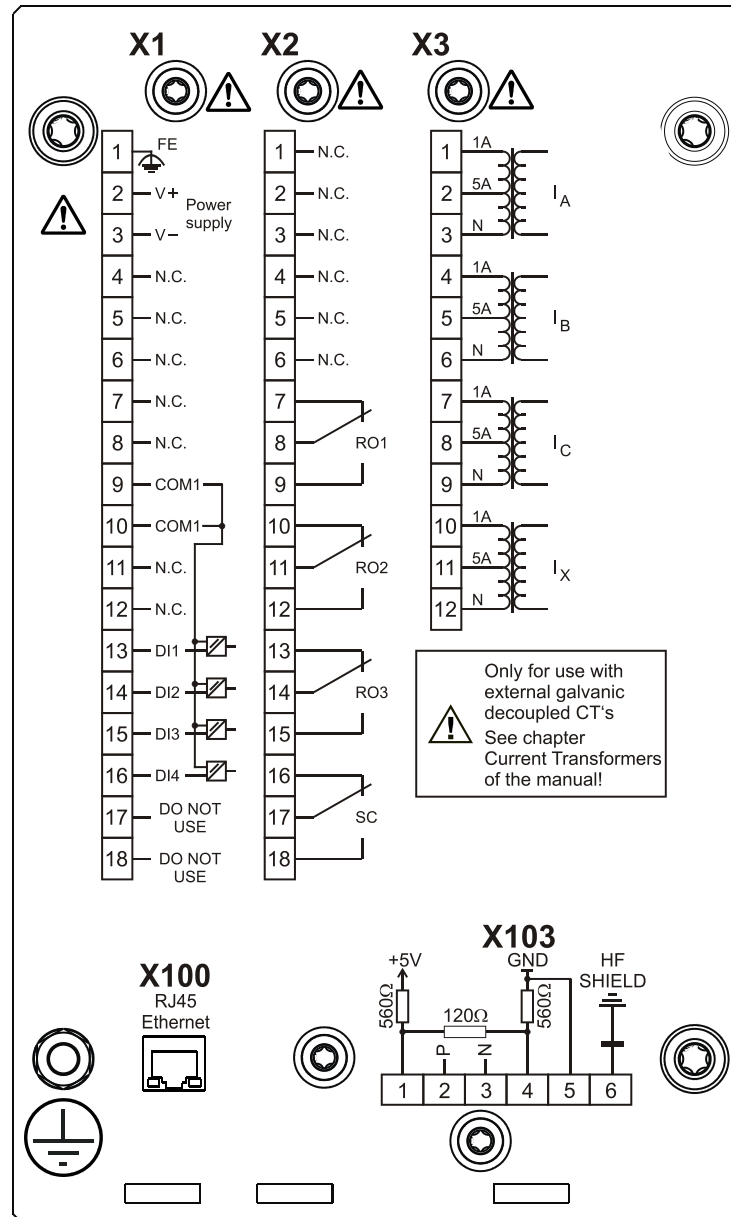

EDR-3000-2A0KA

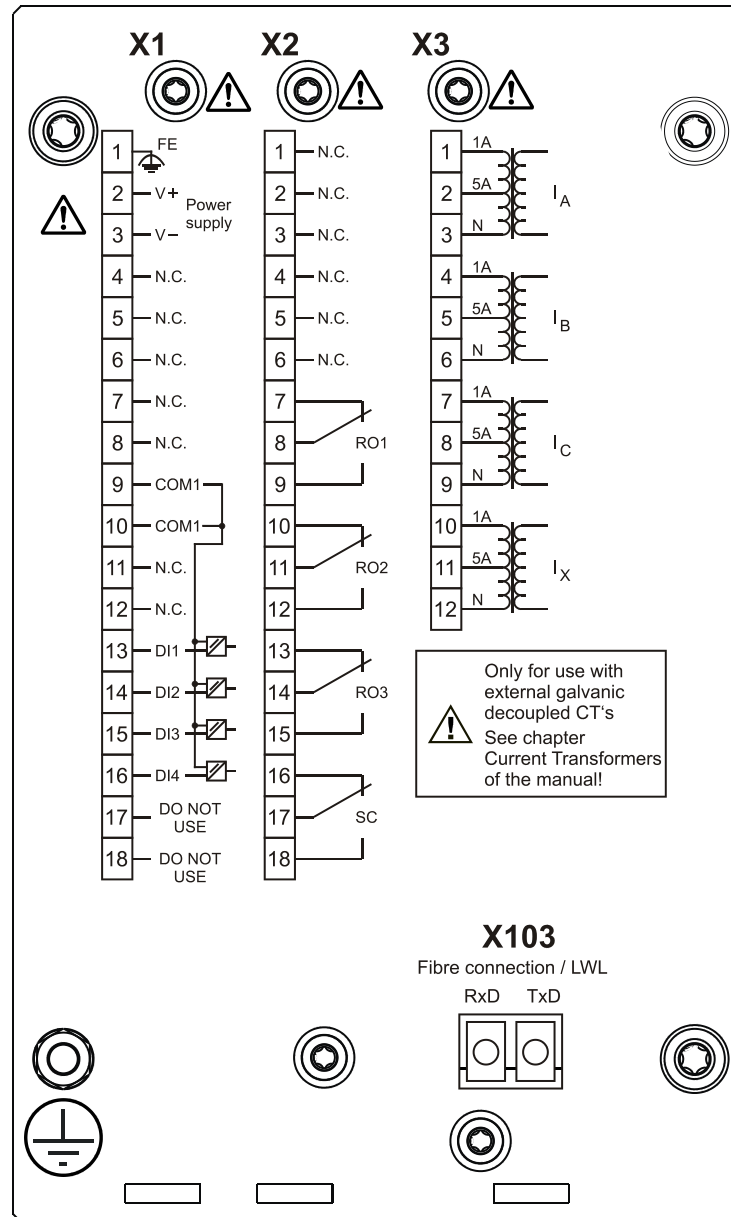

EDR-3000-2A0KB

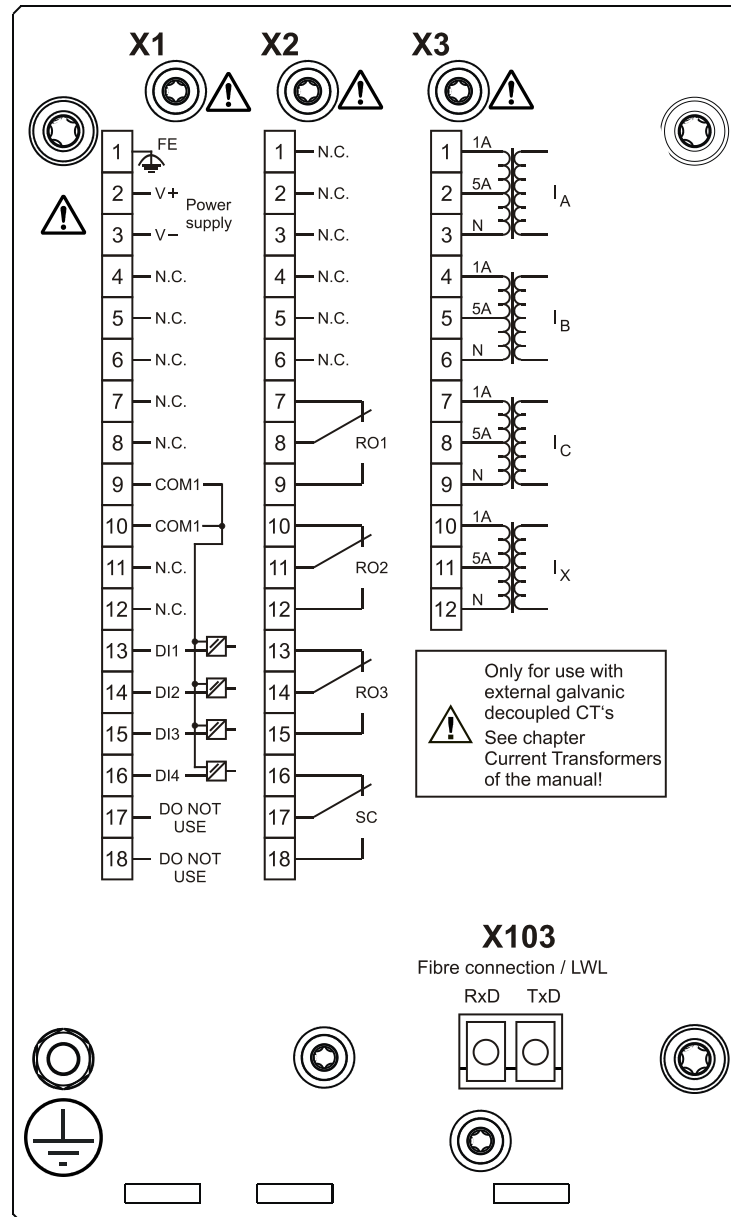

EDR-3000-2A0LA

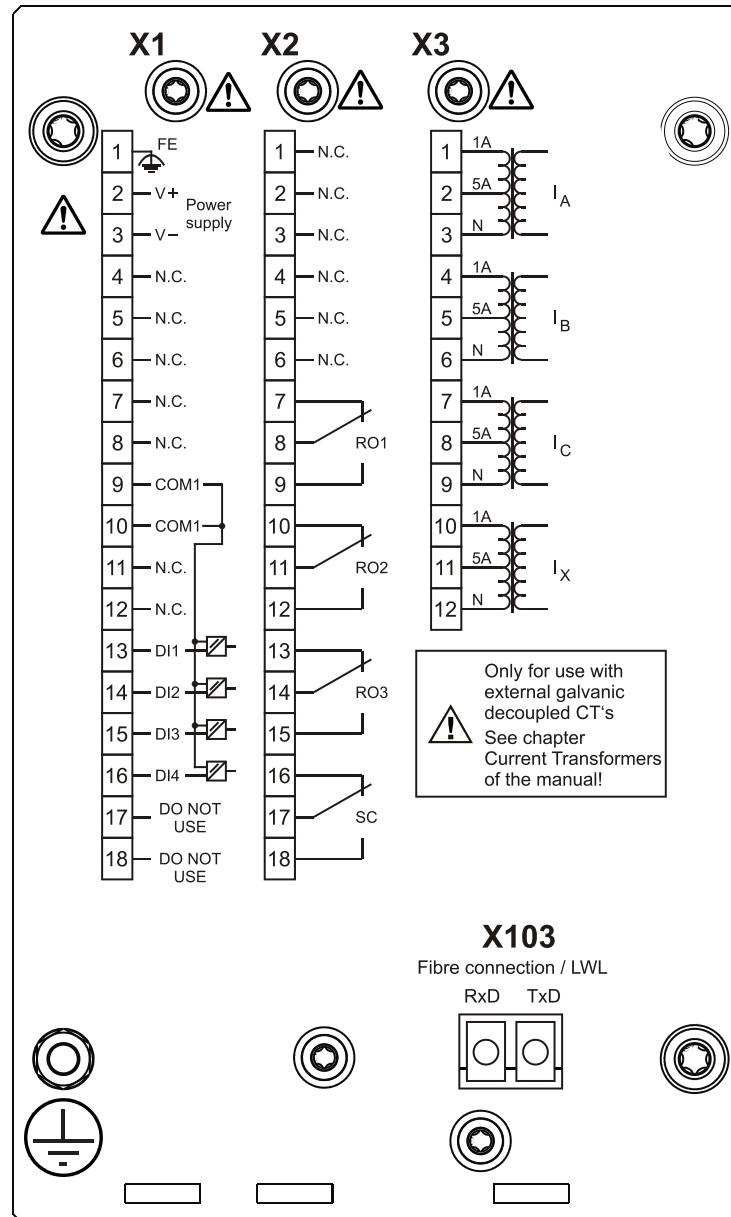

EDR-3000-2A0LB

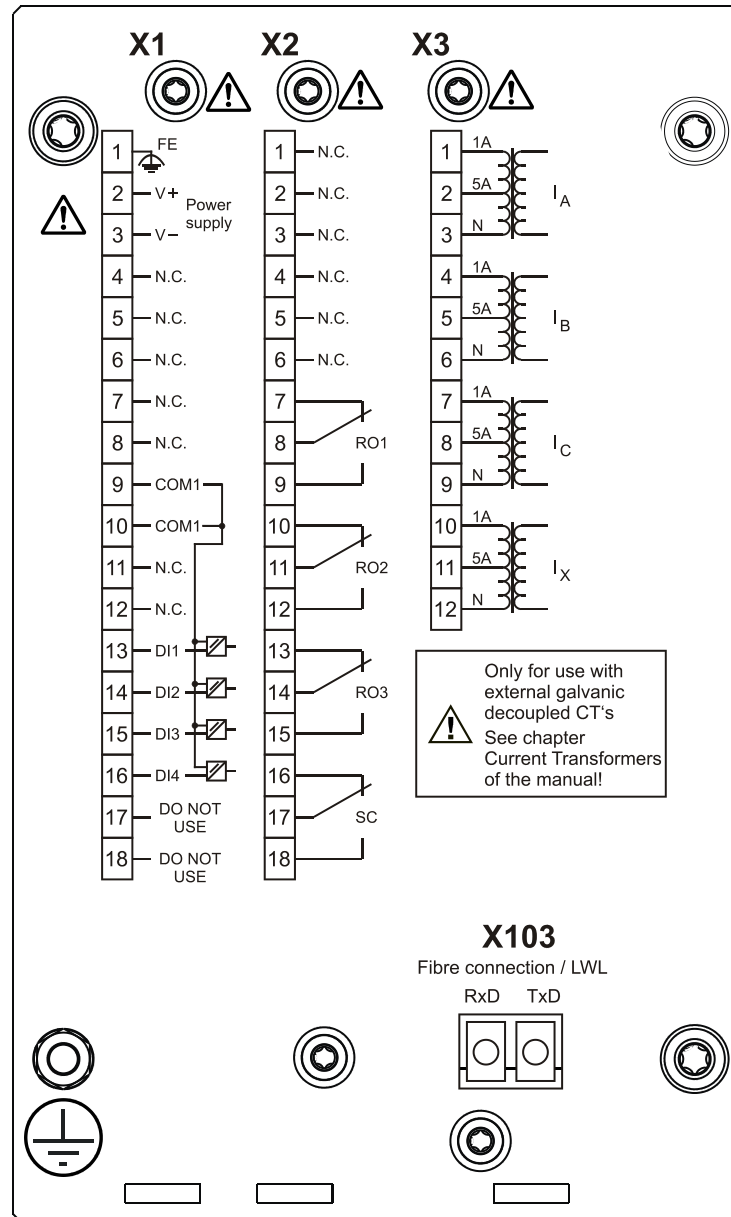

EDR-3000-2A1AA

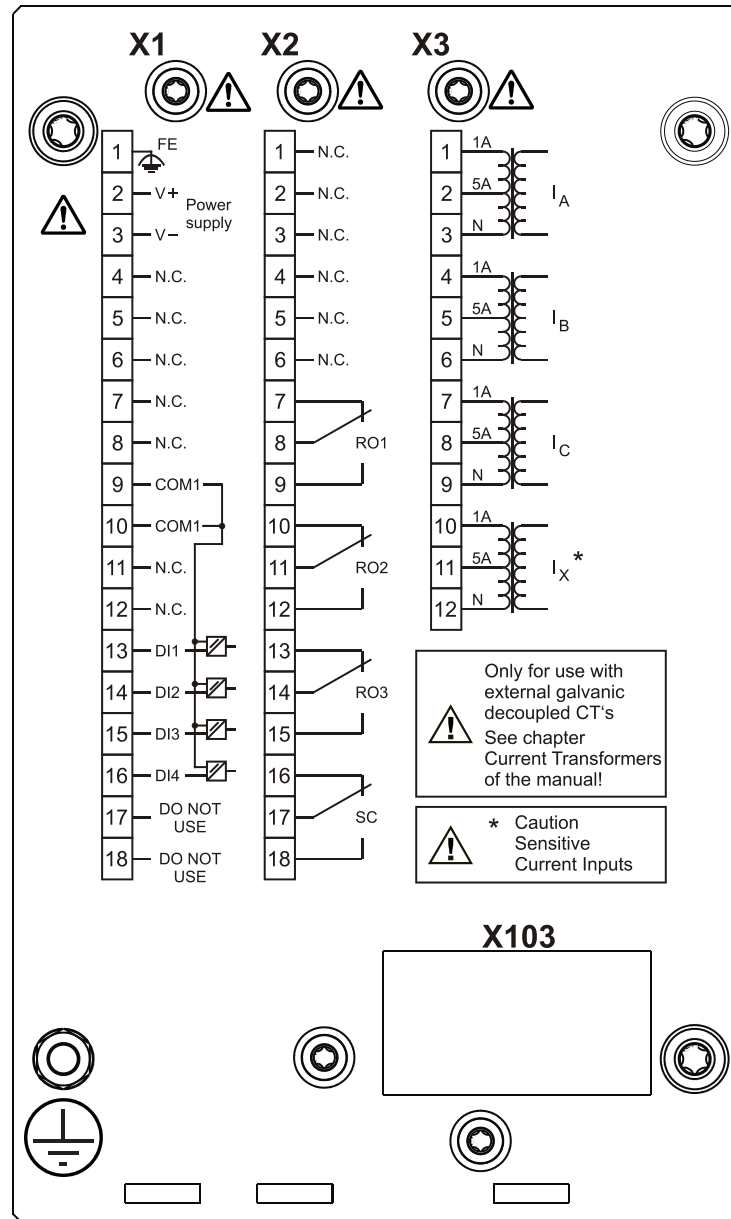

EDR-3000-2A1AB

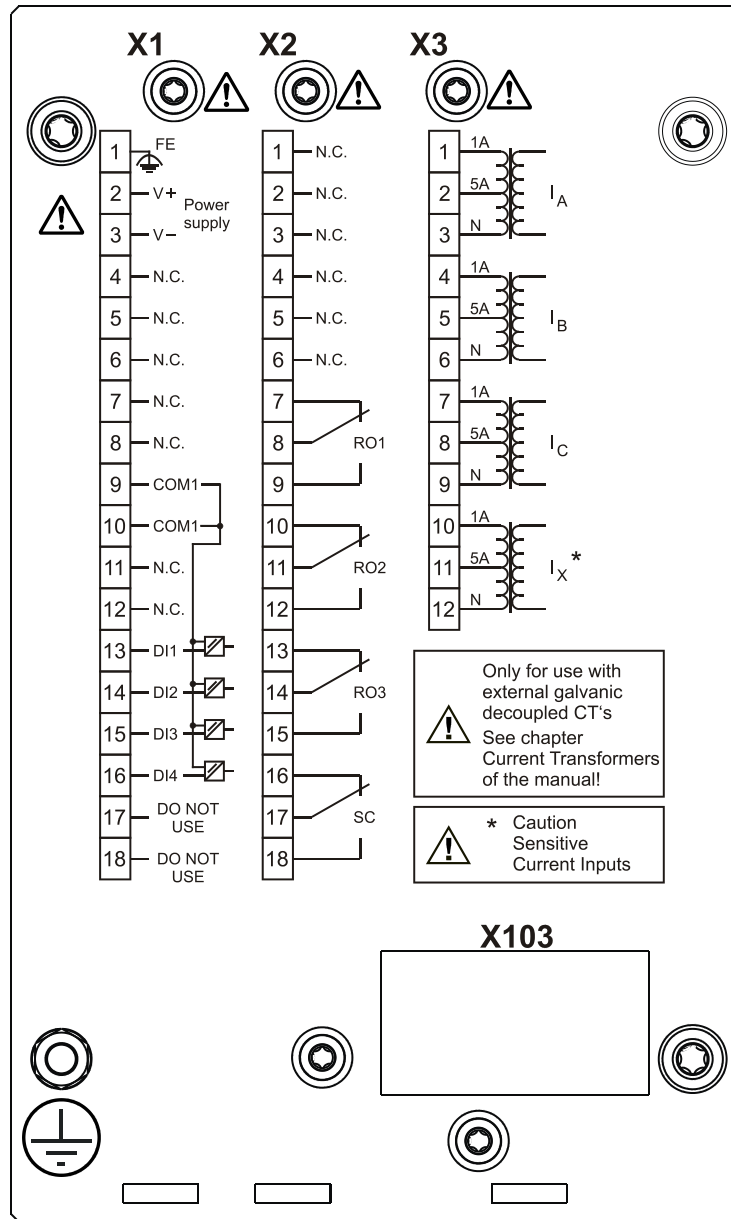

EDR-3000-2A1BA

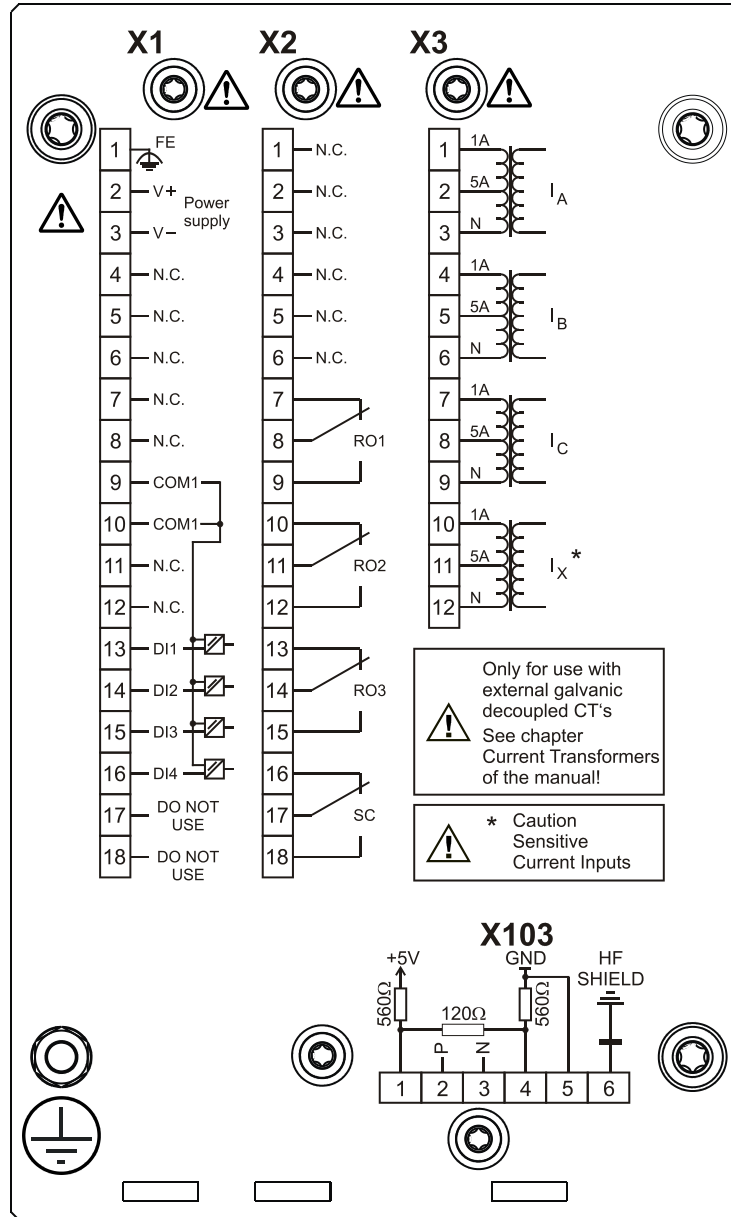

EDR-3000-2A1BB

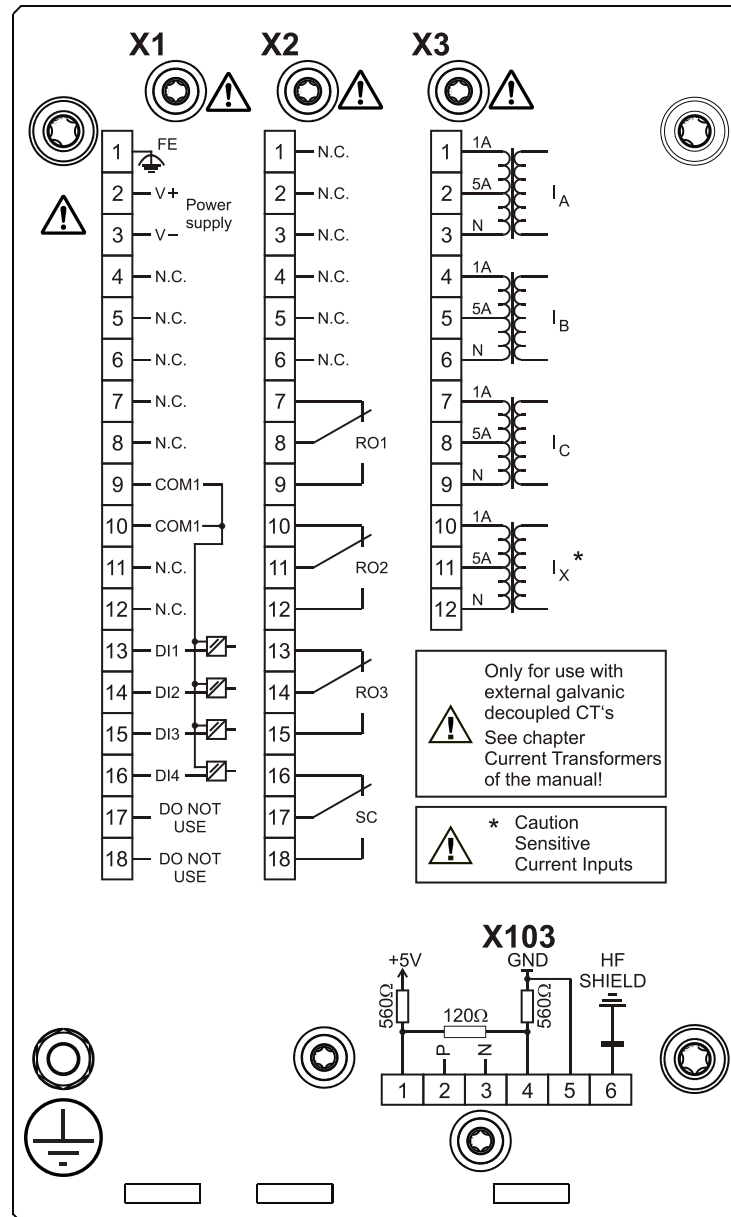

EDR-3000-2A1CA

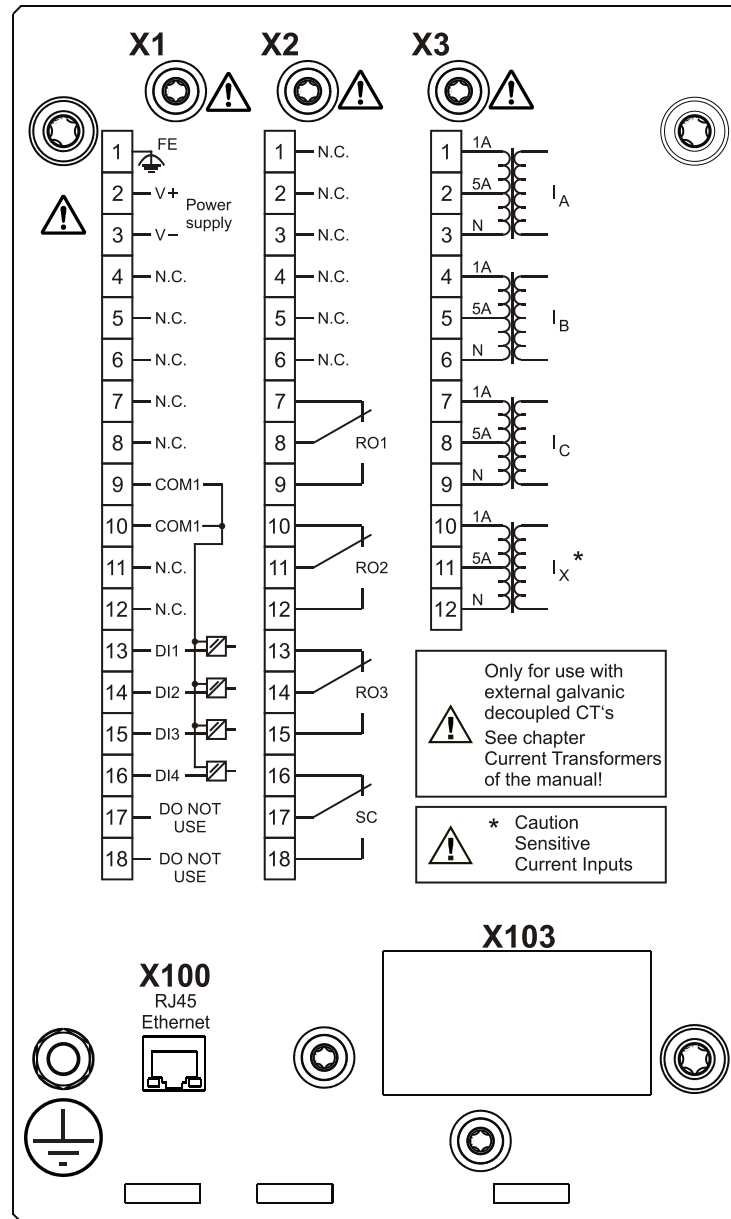

EDR-3000-2A1CB

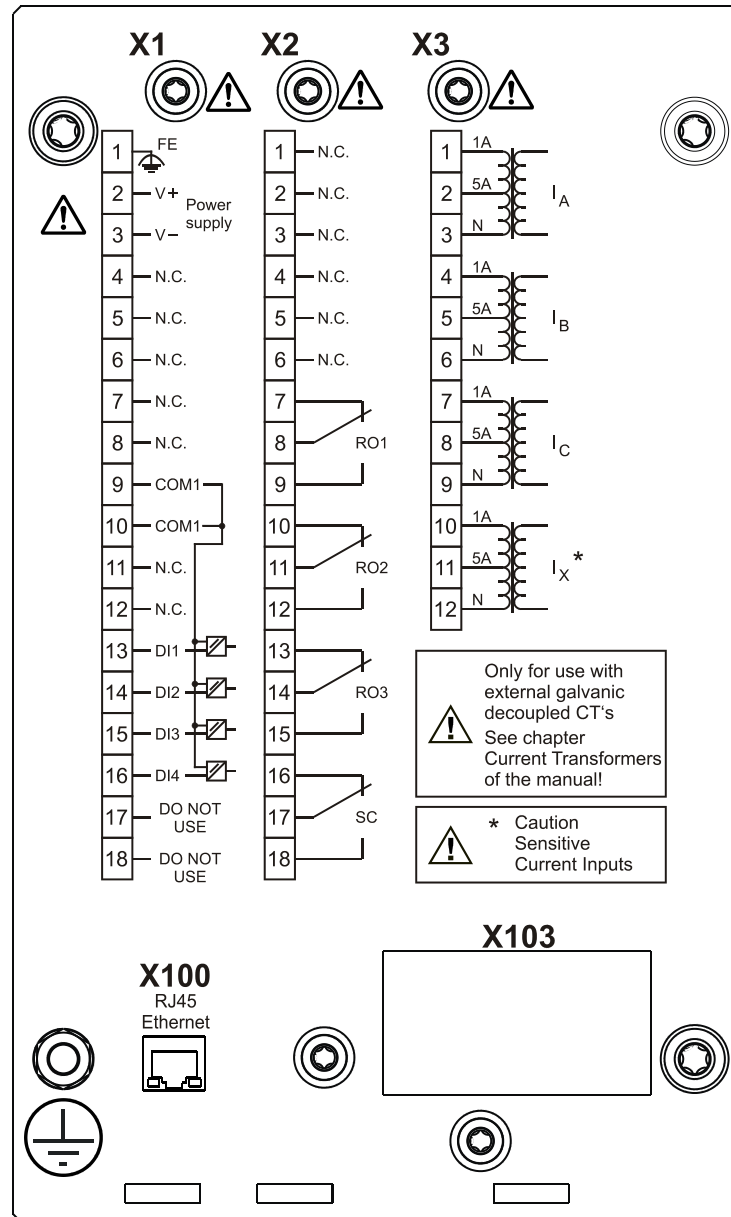

EDR-3000-2A1DA

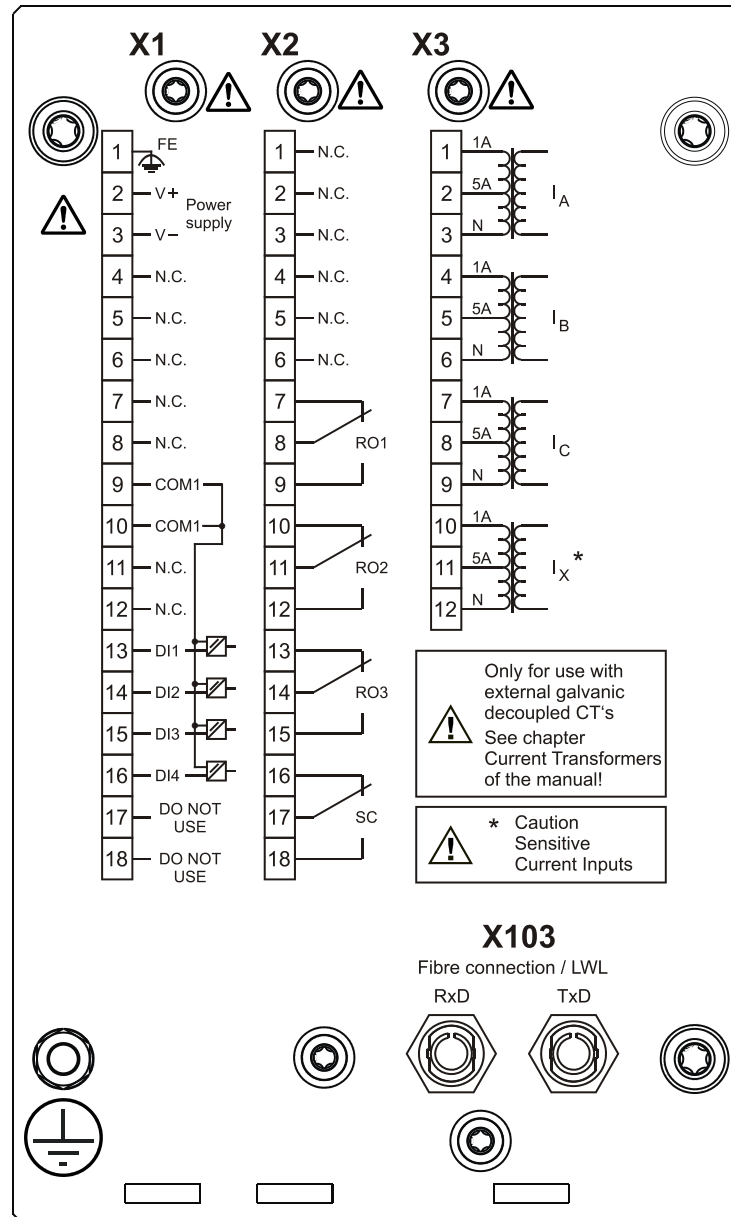

⚠ Only for use with external galvanic decoupled CT's
See chapter Current Transformers of the manual!

⚠ * Caution Sensitive Current Inputs

EDR-3000-2A1DB

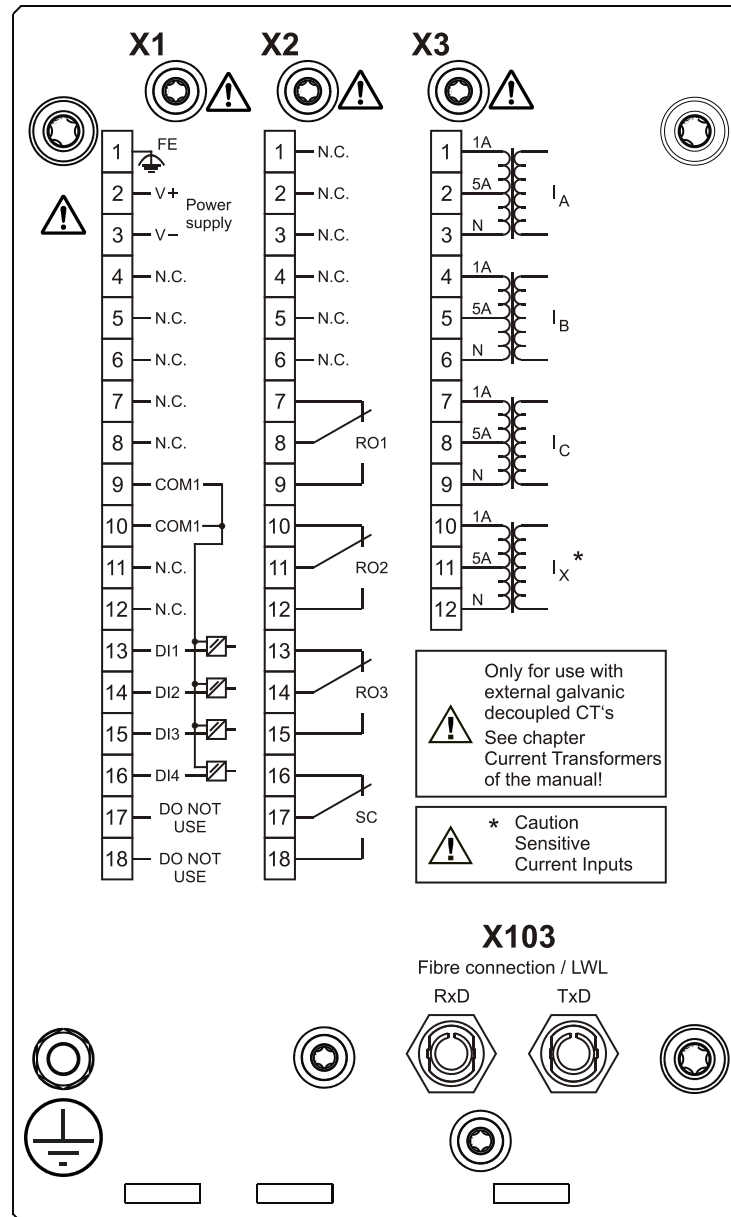

EDR-3000-2A1EA

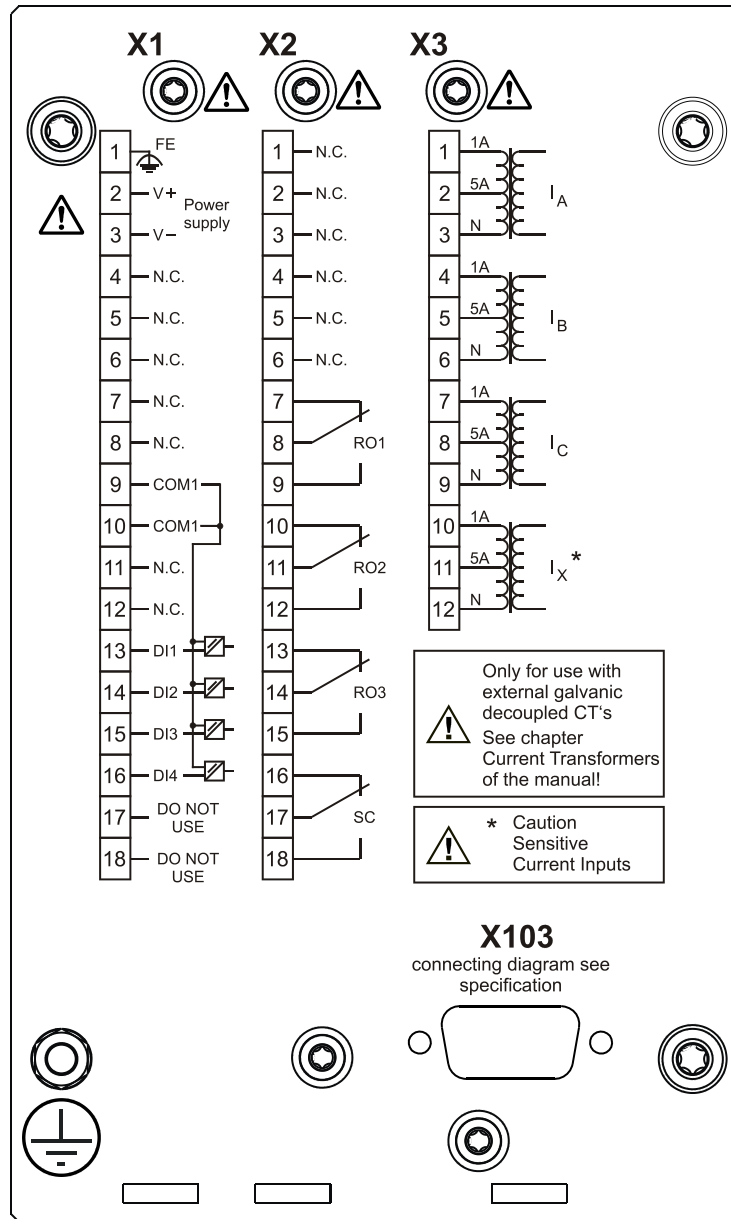

EDR-3000-2A1EB

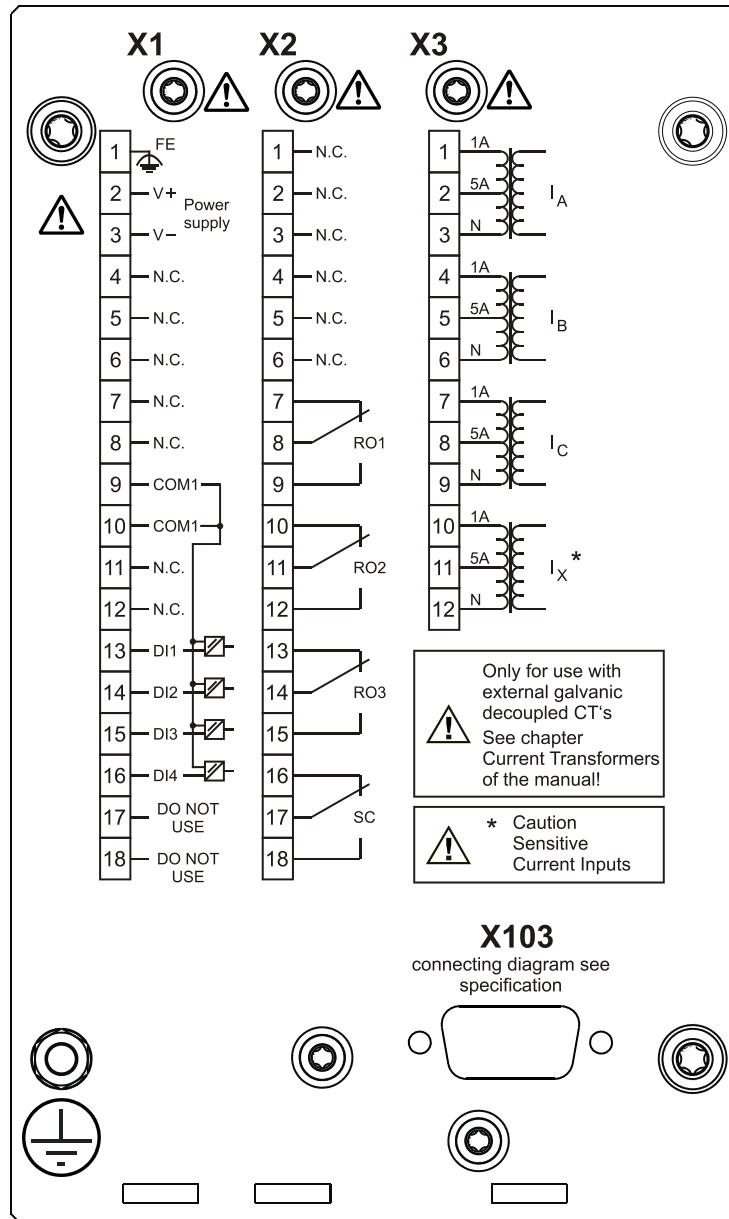

EDR-3000-2A1FA

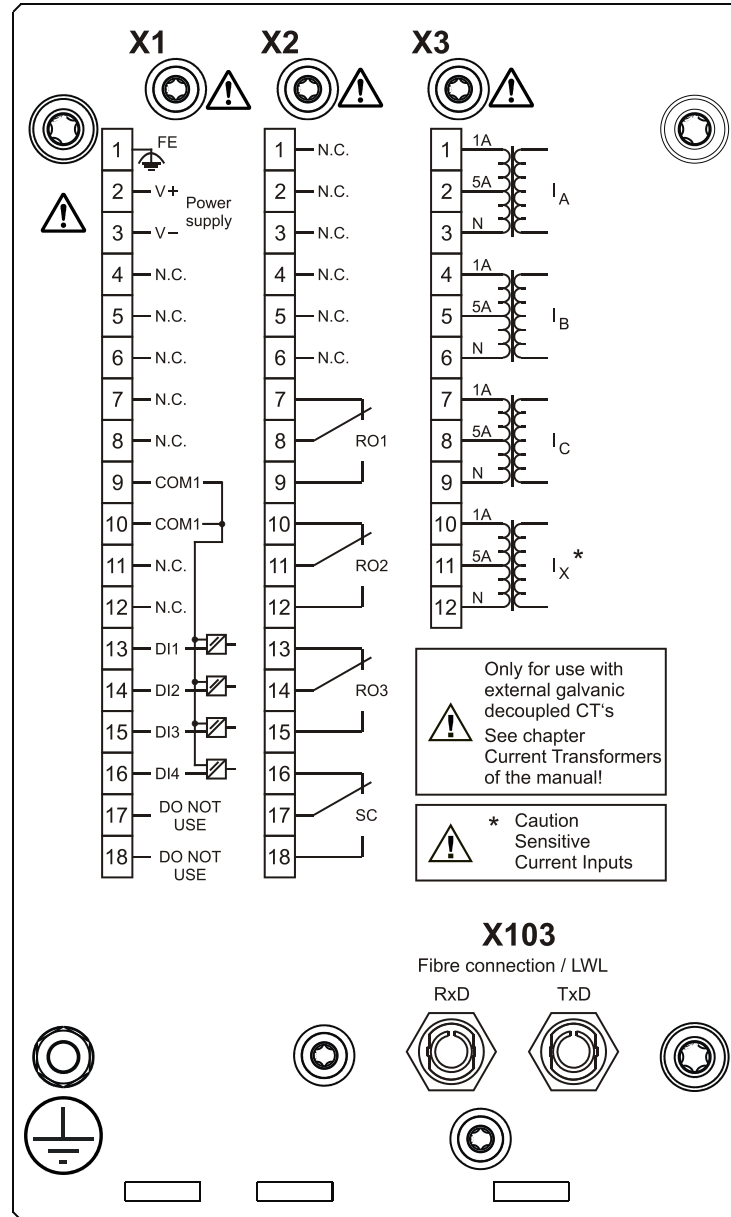

EDR-3000-2A1FB

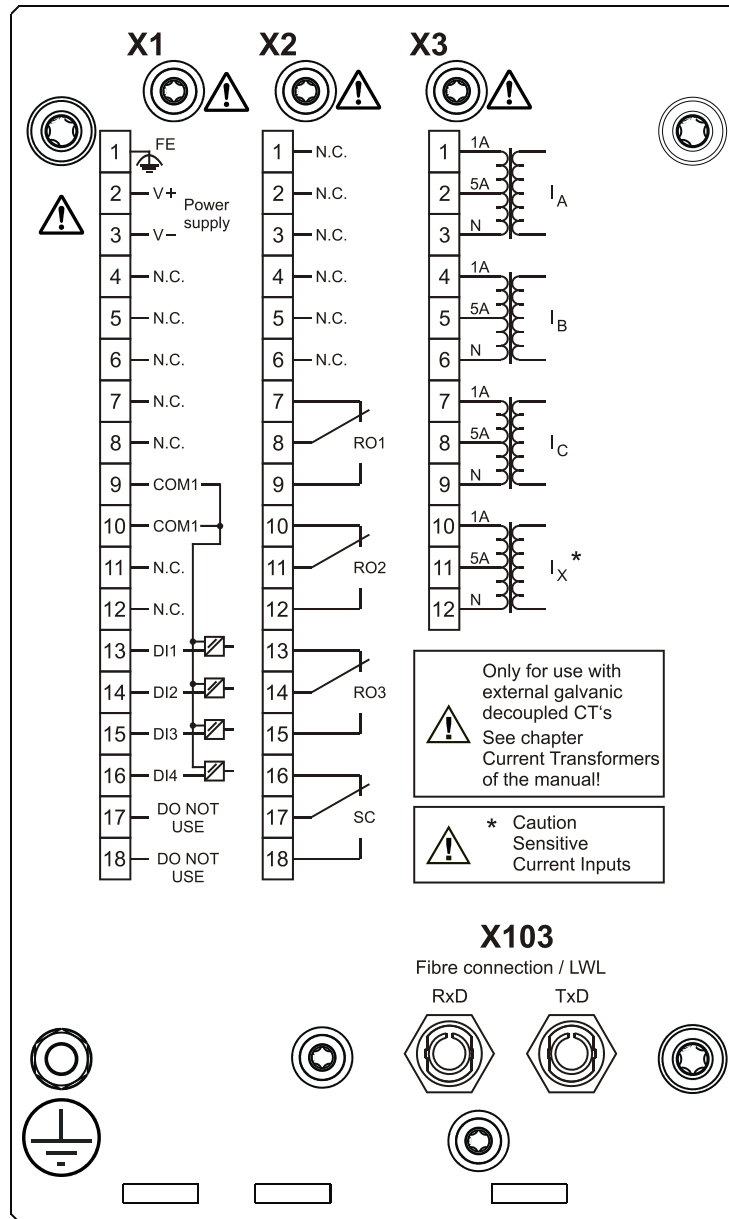

EDR-3000-2A1GA

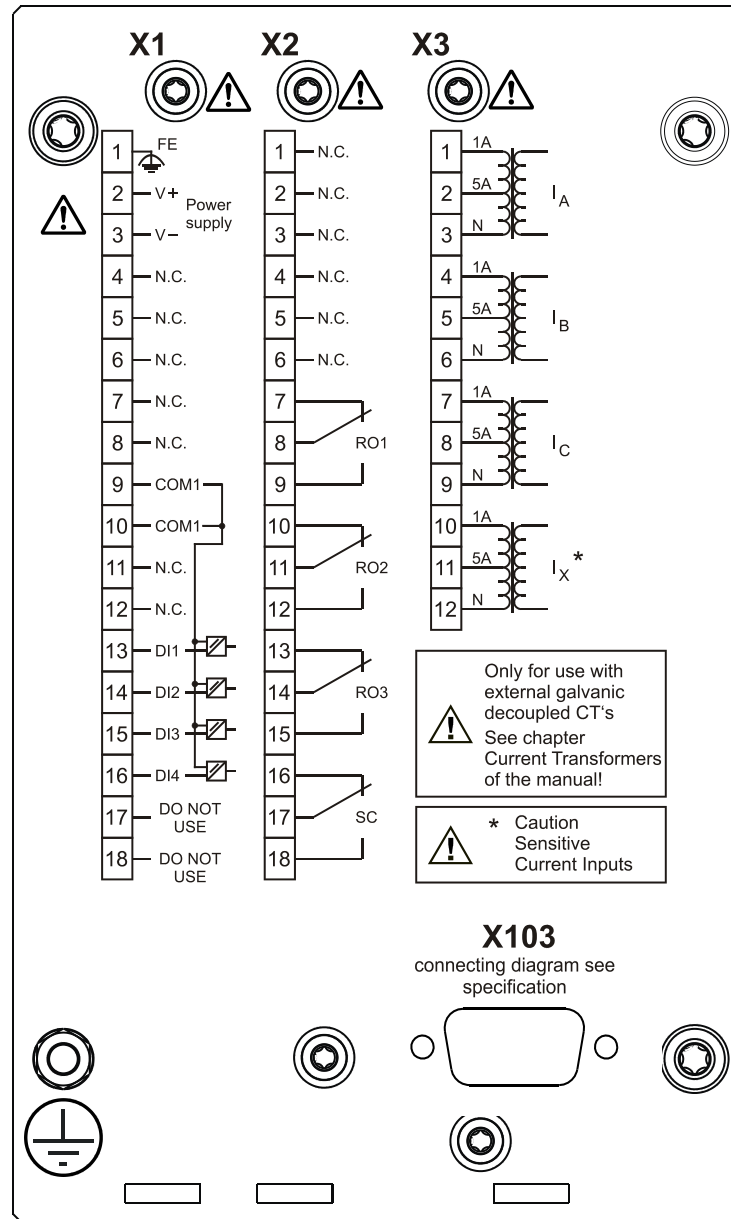

EDR-3000-2A1GB

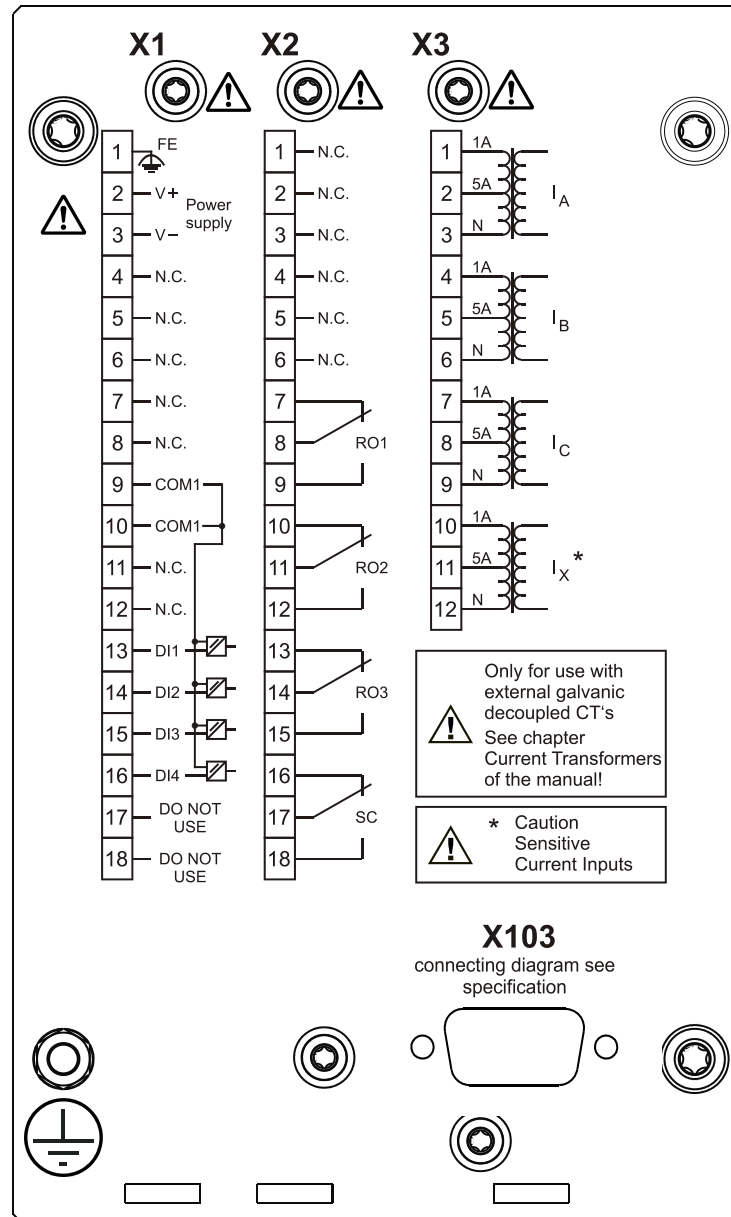

EDR-3000-2A1HA

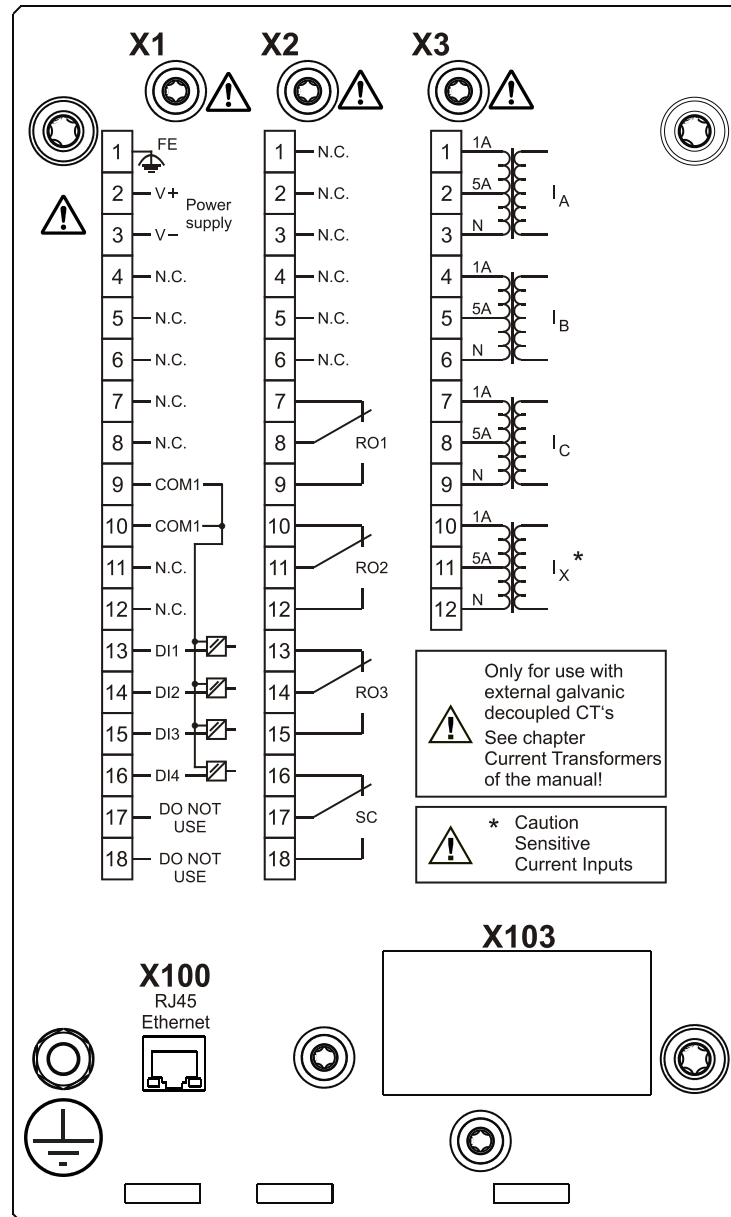

EDR-3000-2A1HB

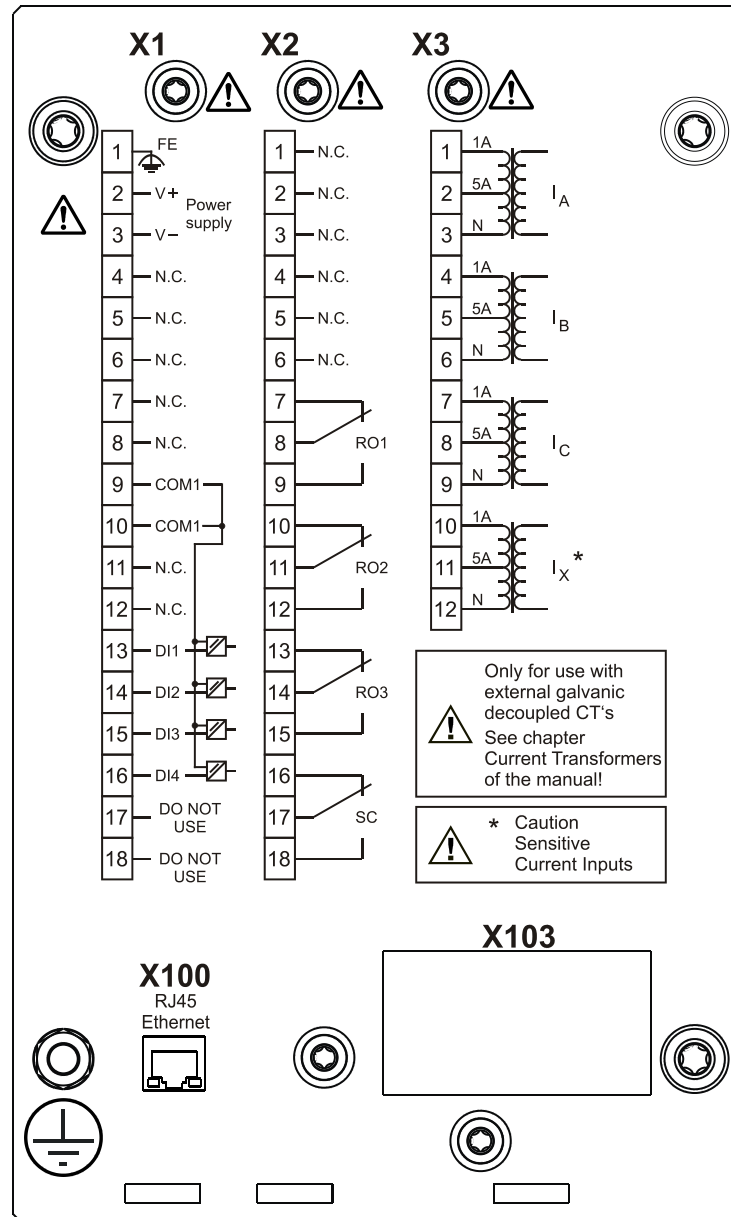

EDR-3000-2A1IA

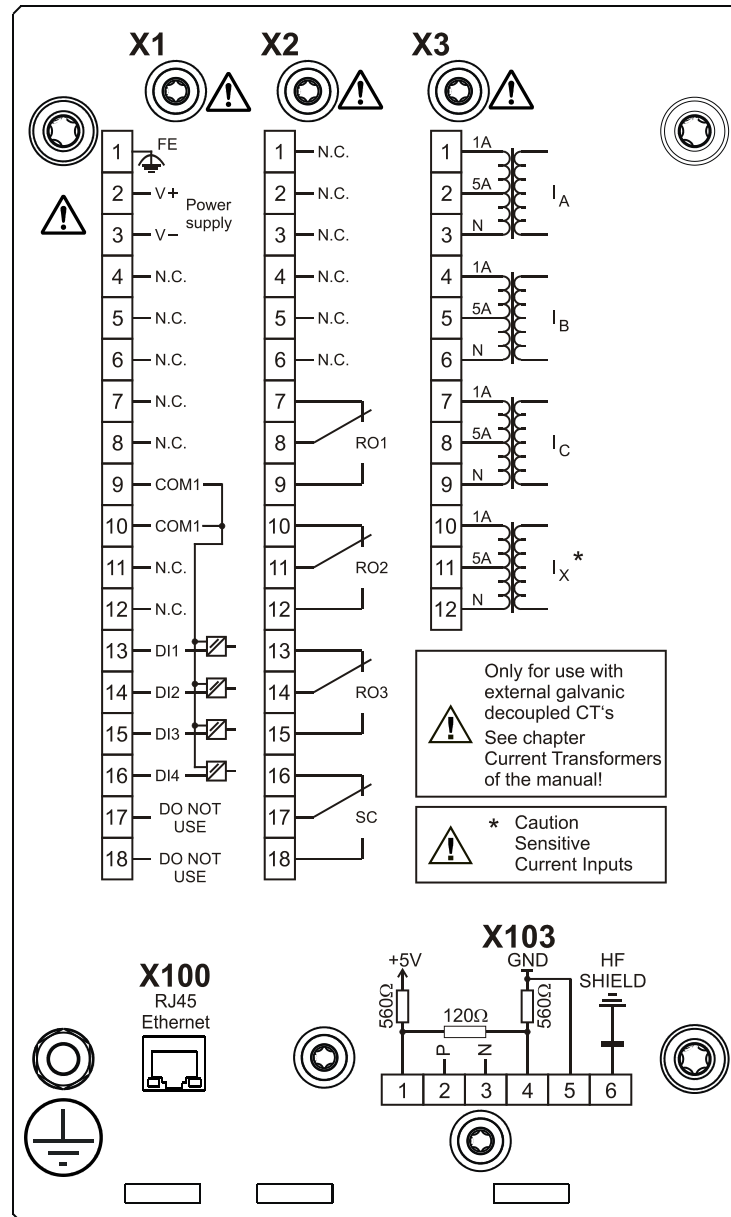

EDR-3000-2A1IB

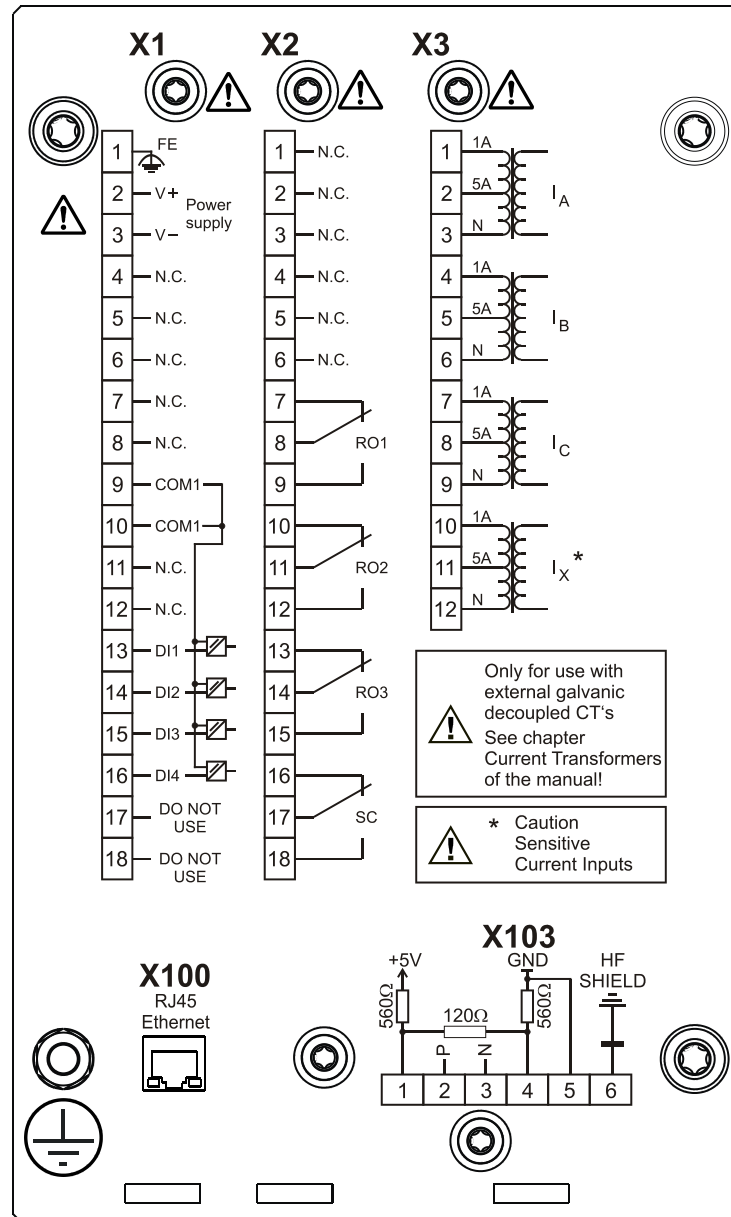

EDR-3000-2A1KA

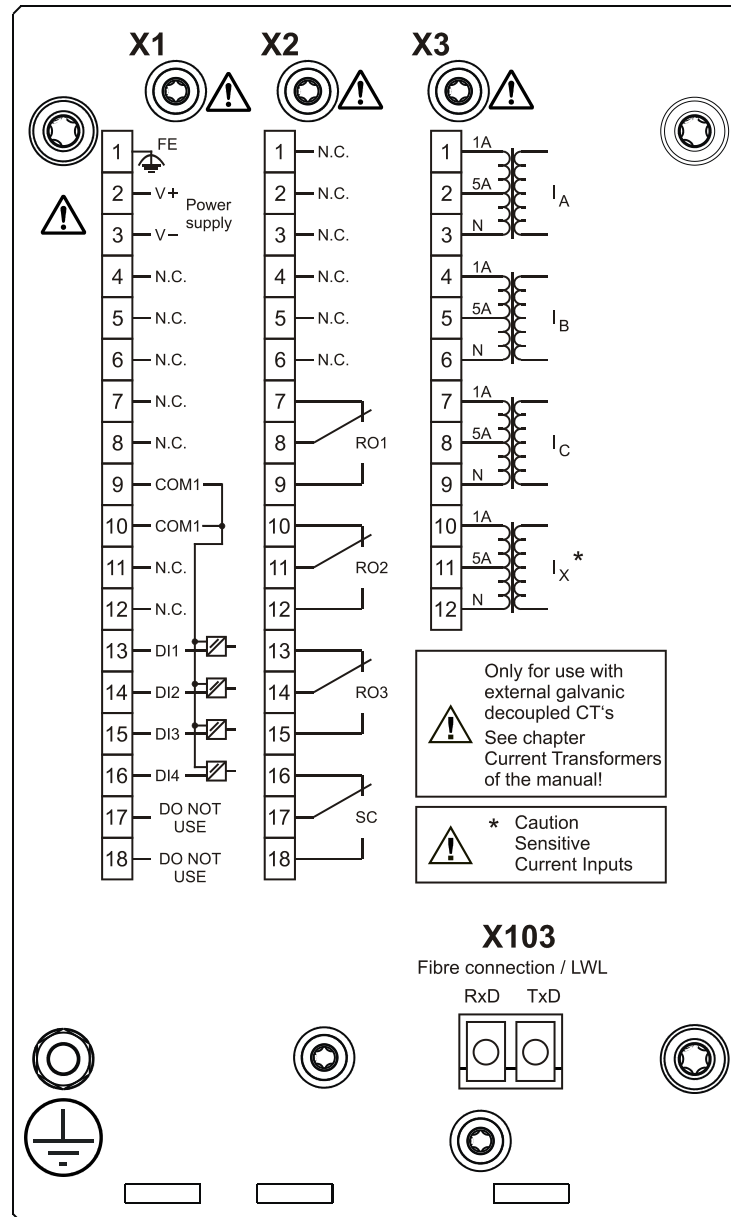

EDR-3000-2A1KB

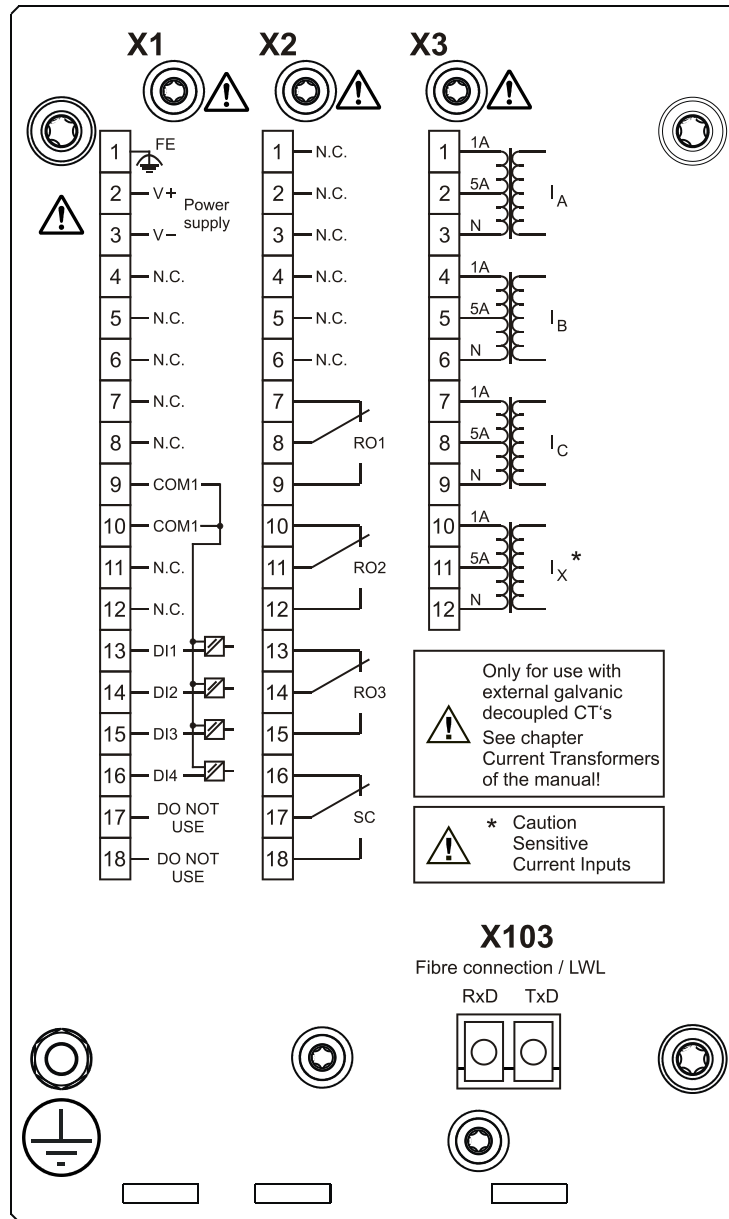

EDR-3000-2A1LA

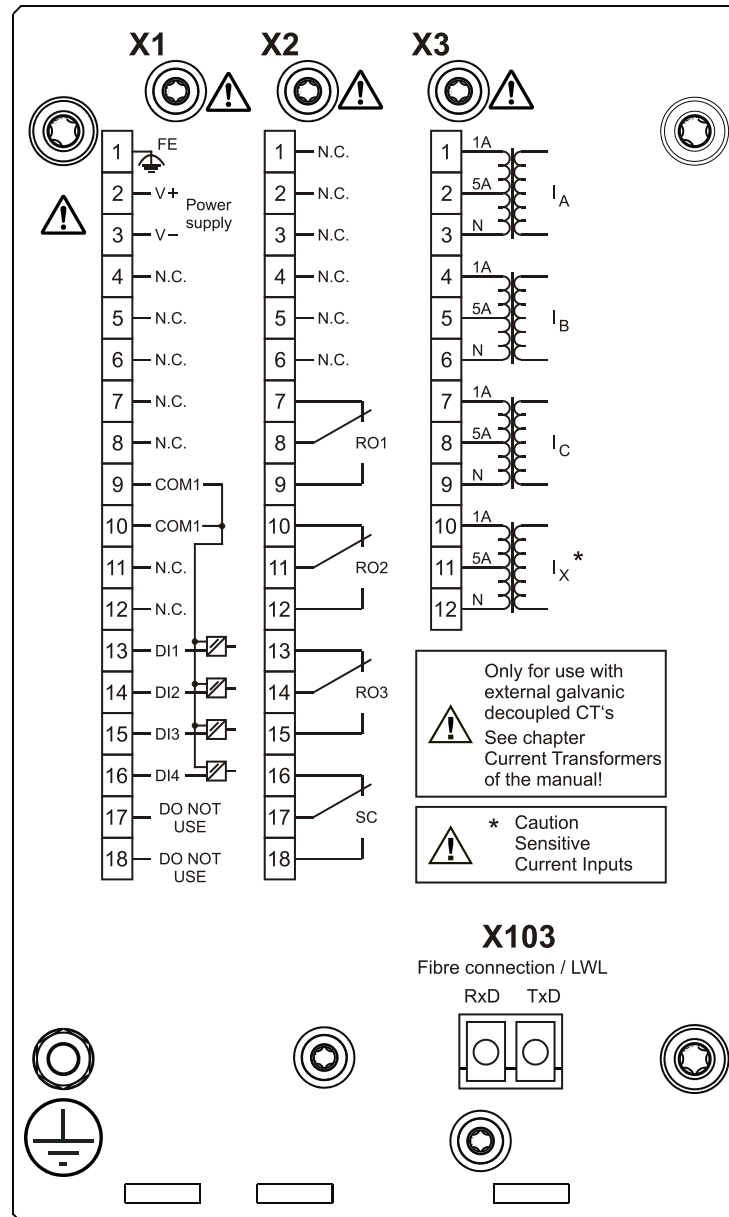

EDR-3000-2A1LB

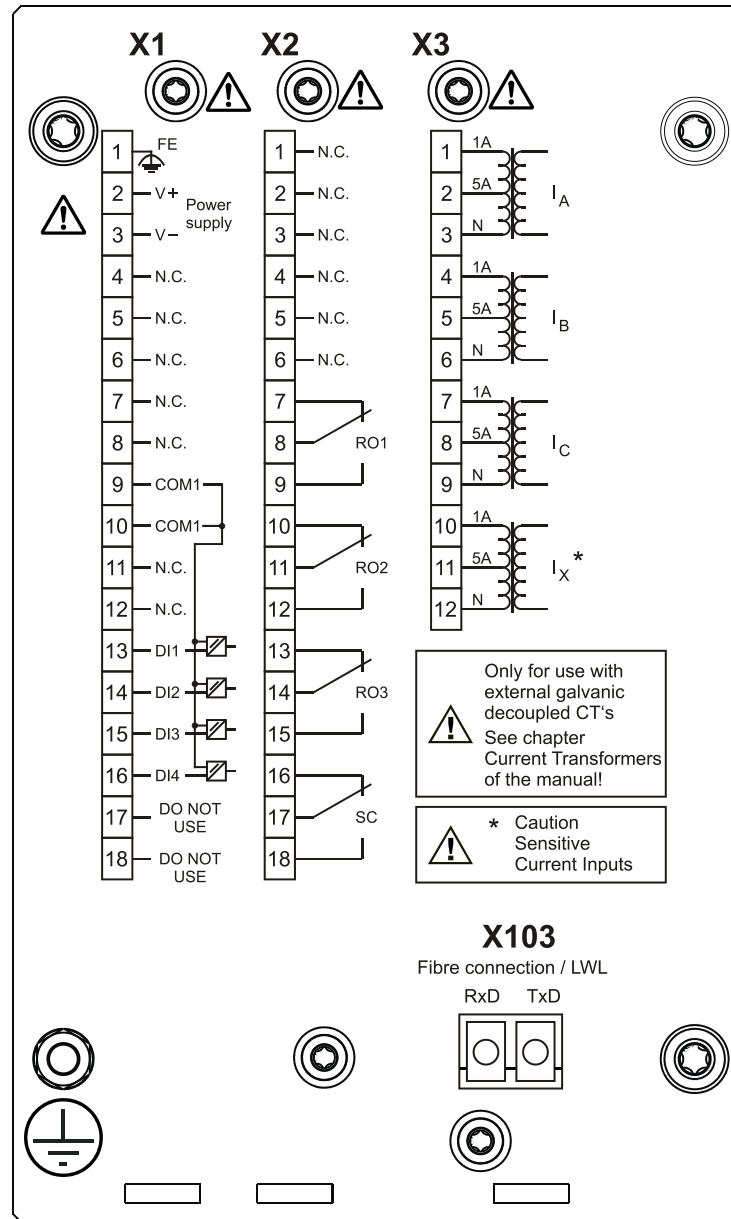

EDR-3000-2B0AA

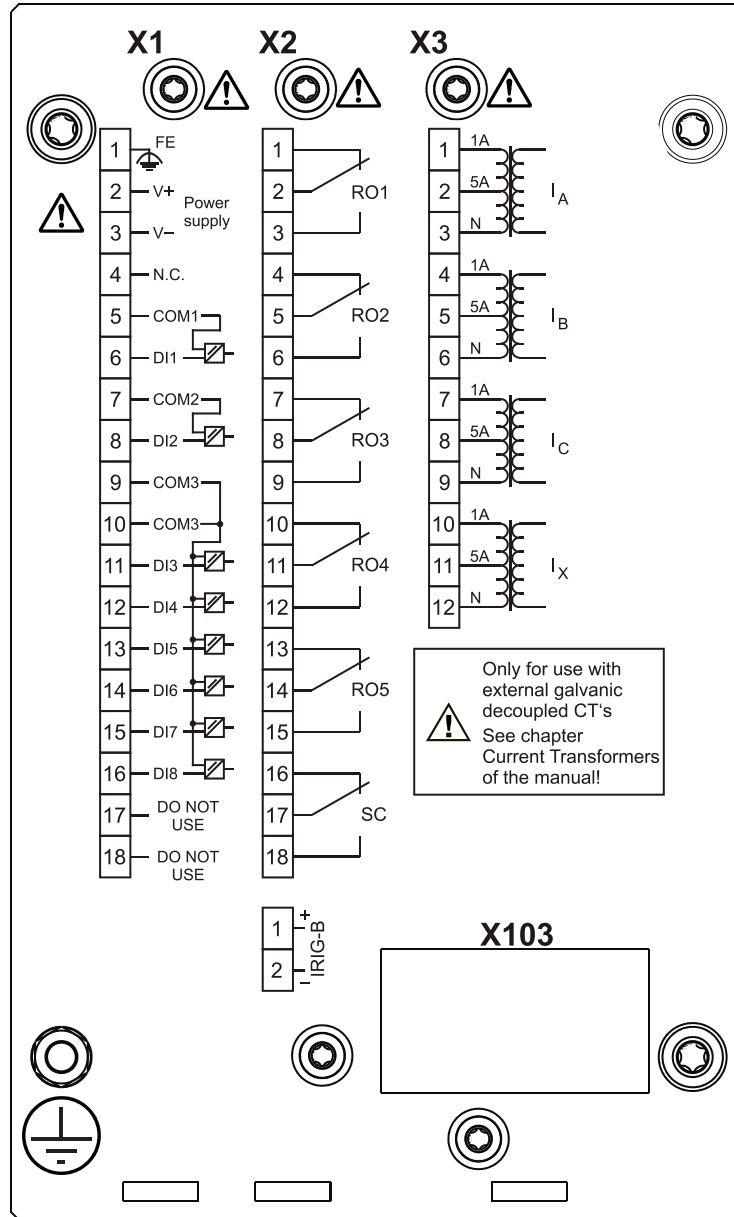

EDR-3000-2B0AB

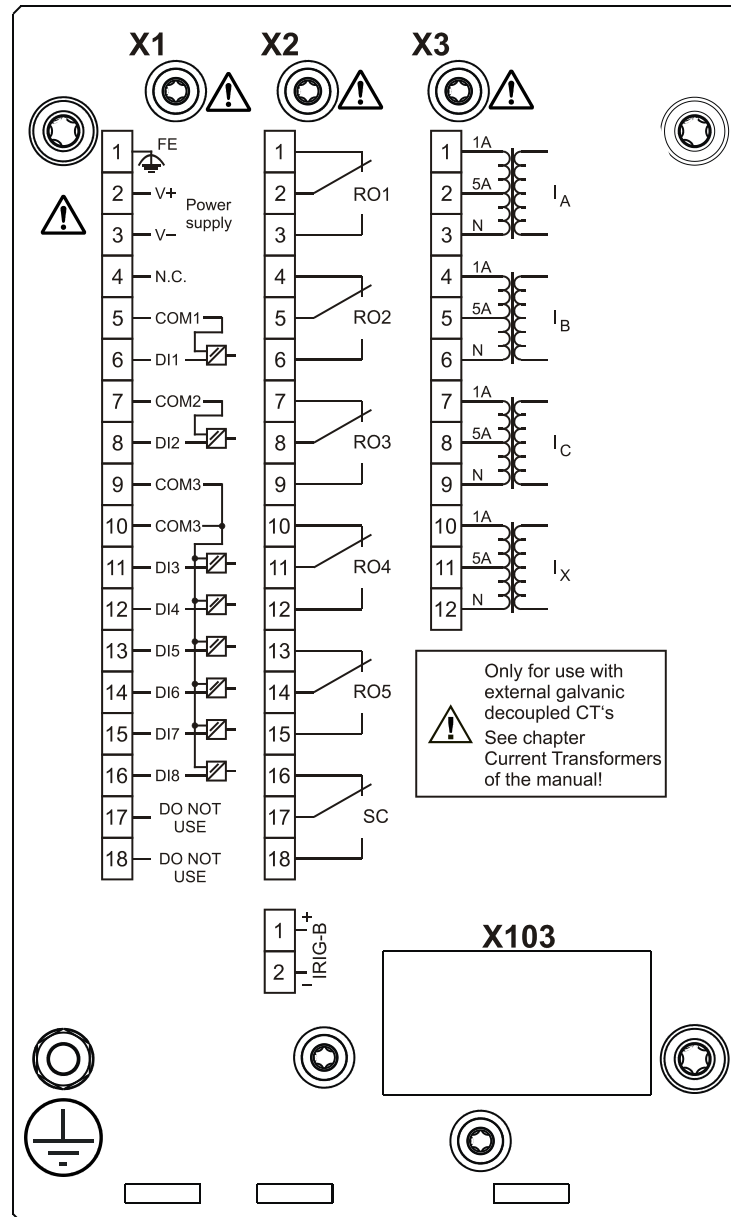

EDR-3000-2B0BA

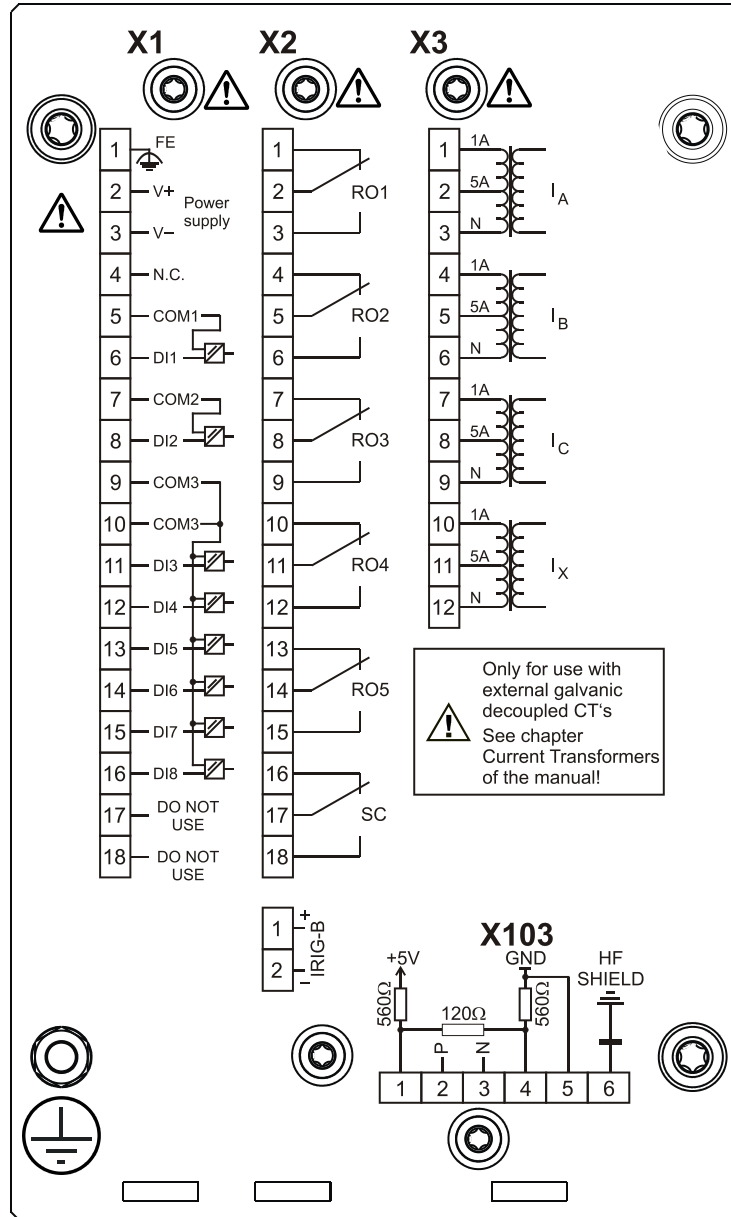

EDR-3000-2B0BB

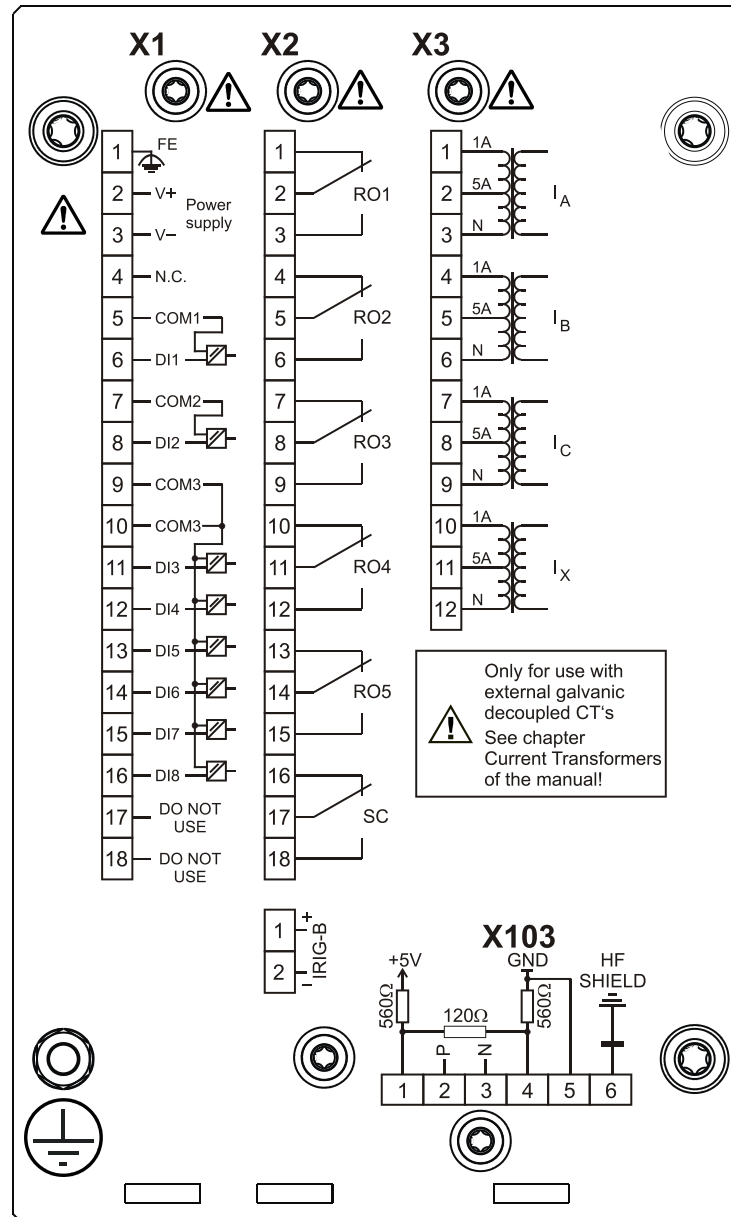

EDR-3000-2B0CA

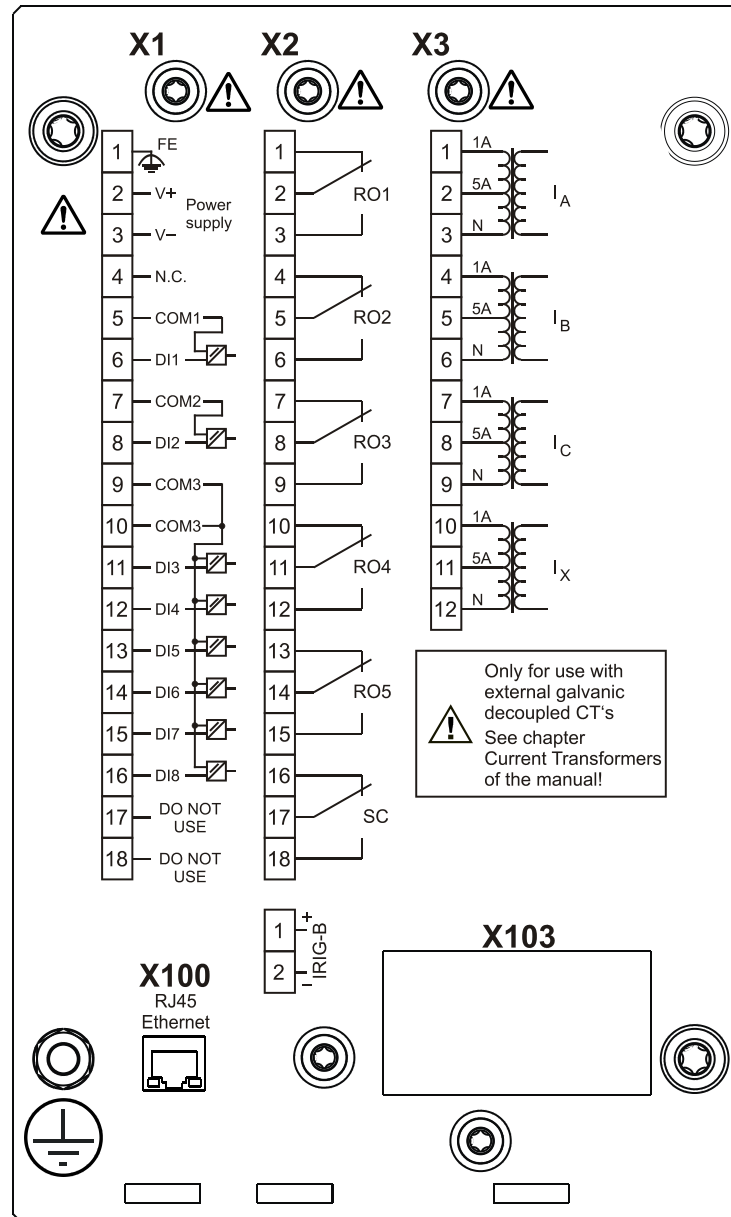

EDR-3000-2B0CB

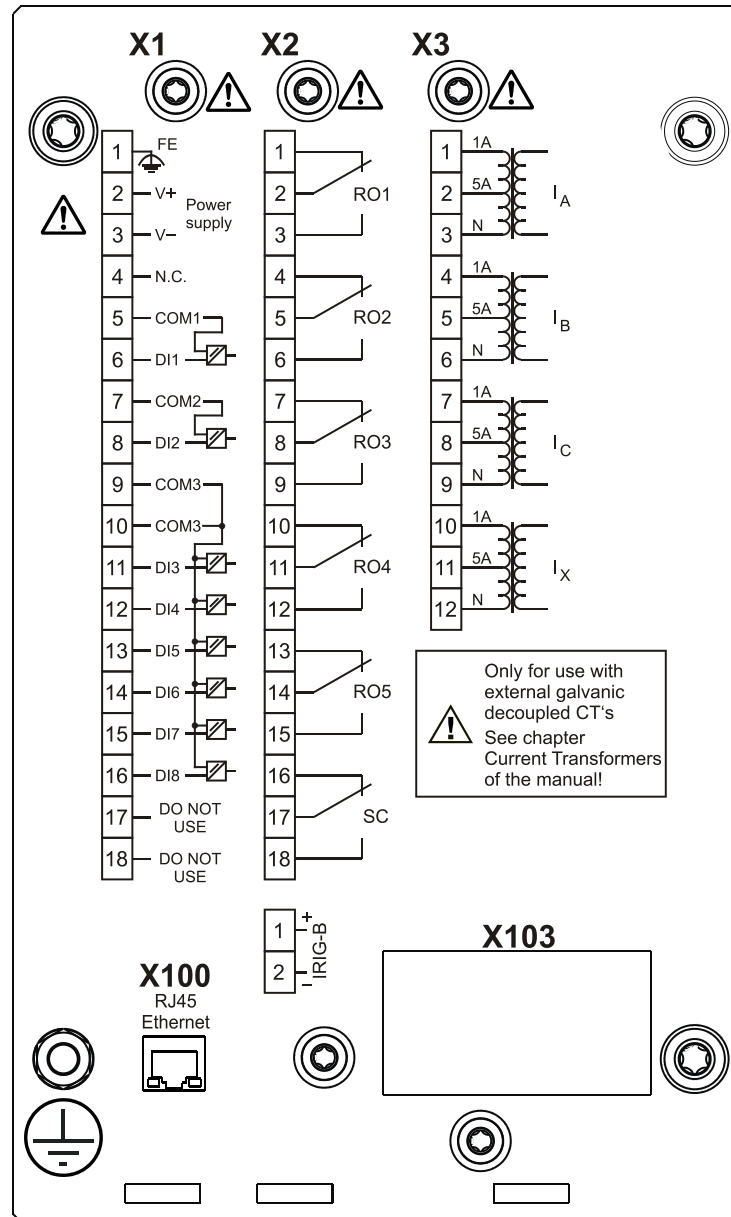

EDR-3000-2B0DA

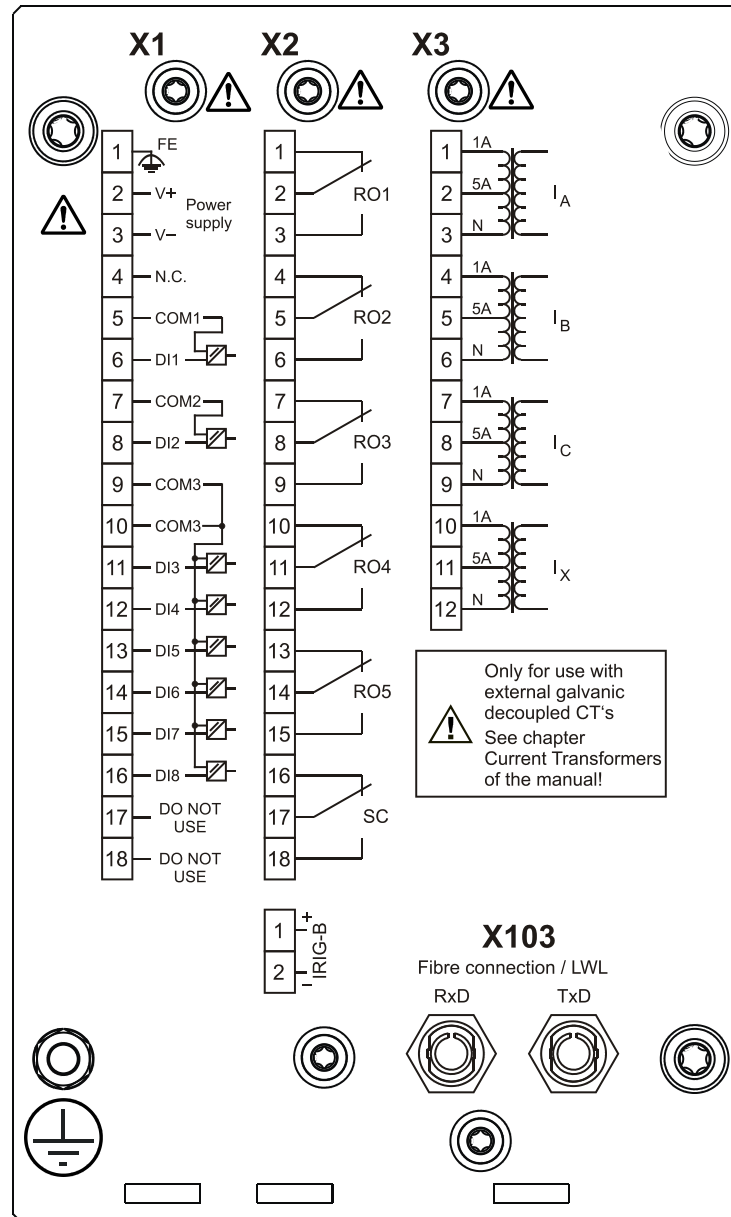

EDR-3000-2B0DB

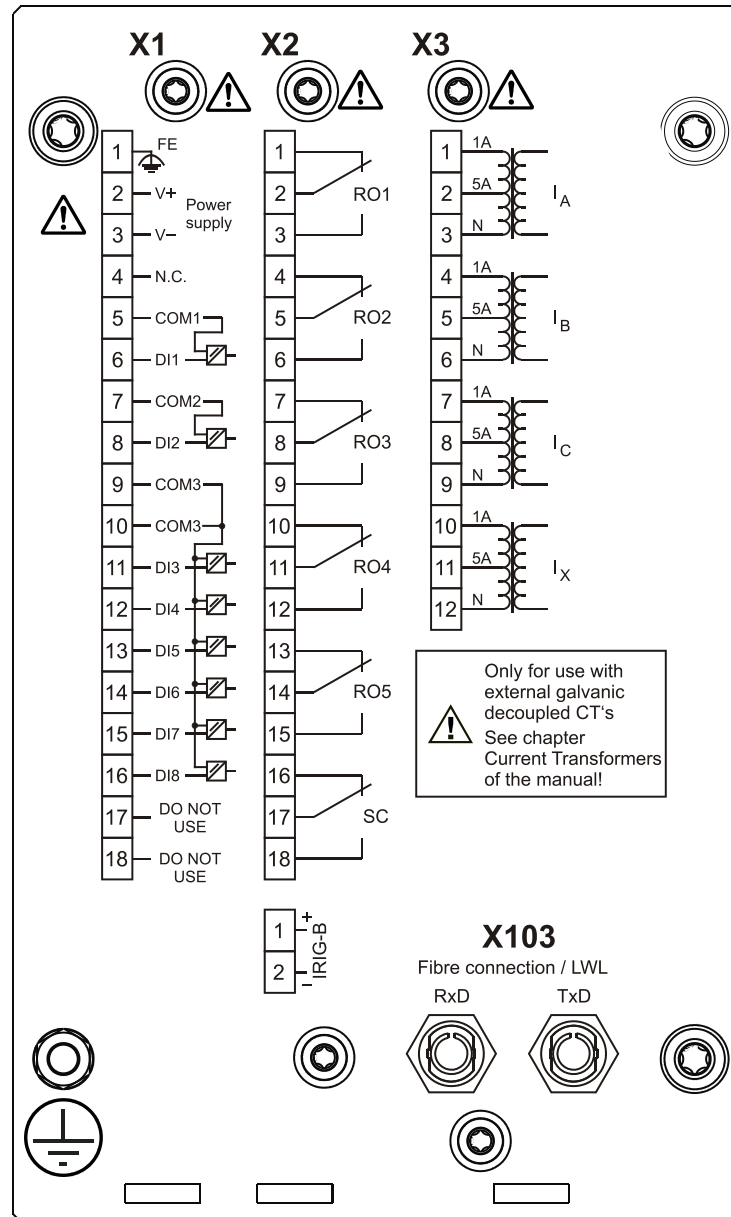

EDR-3000-2B0EA

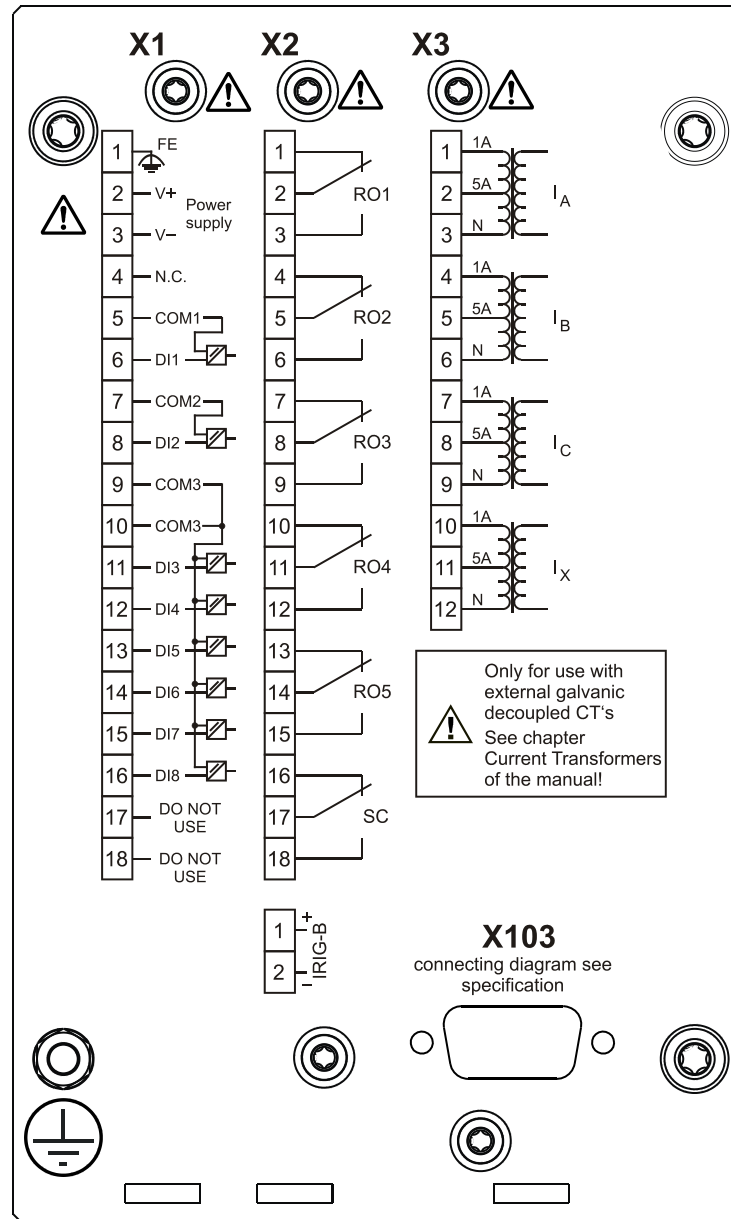

EDR-3000-2B0EB

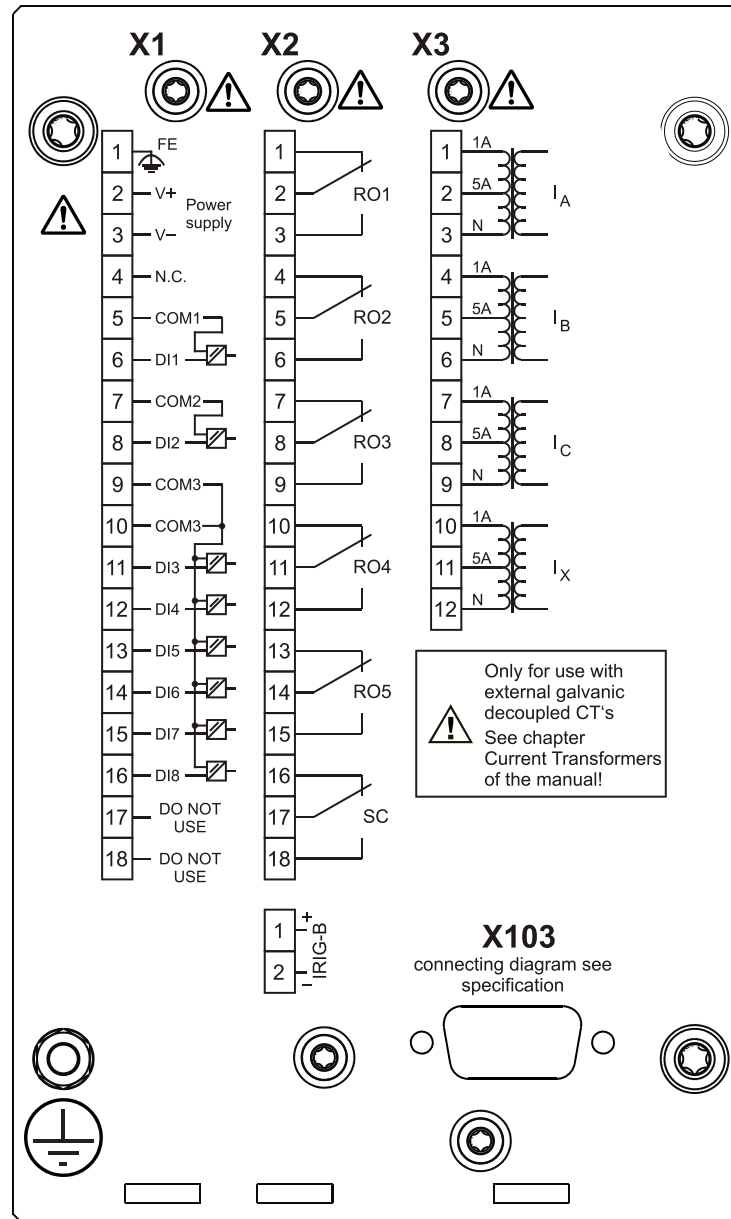

EDR-3000-2B0FA

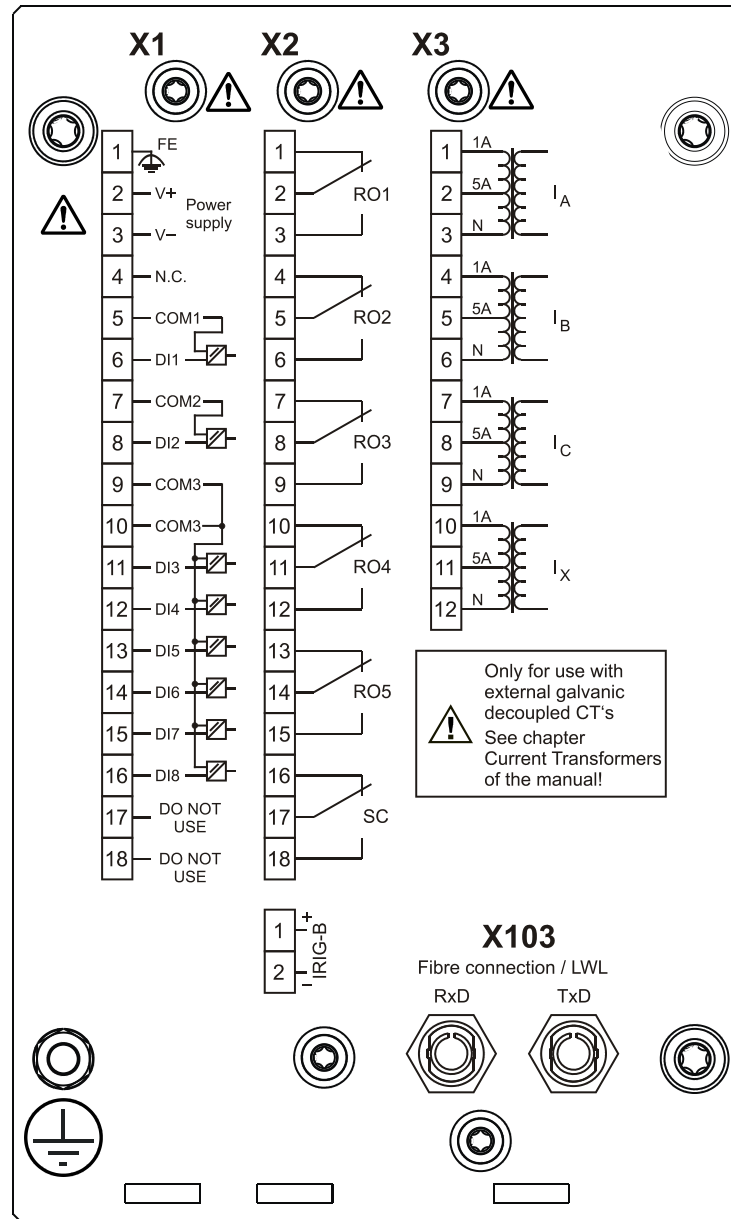

EDR-3000-2B0FB

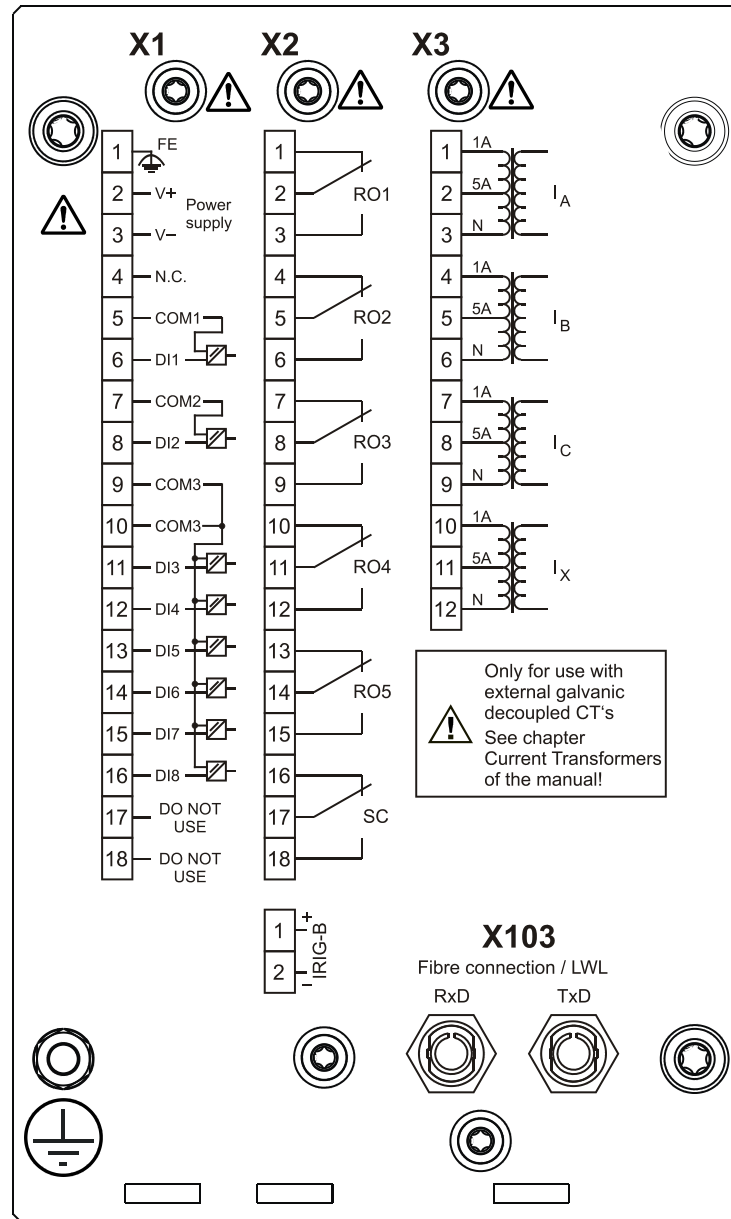

EDR-3000-2B0GA

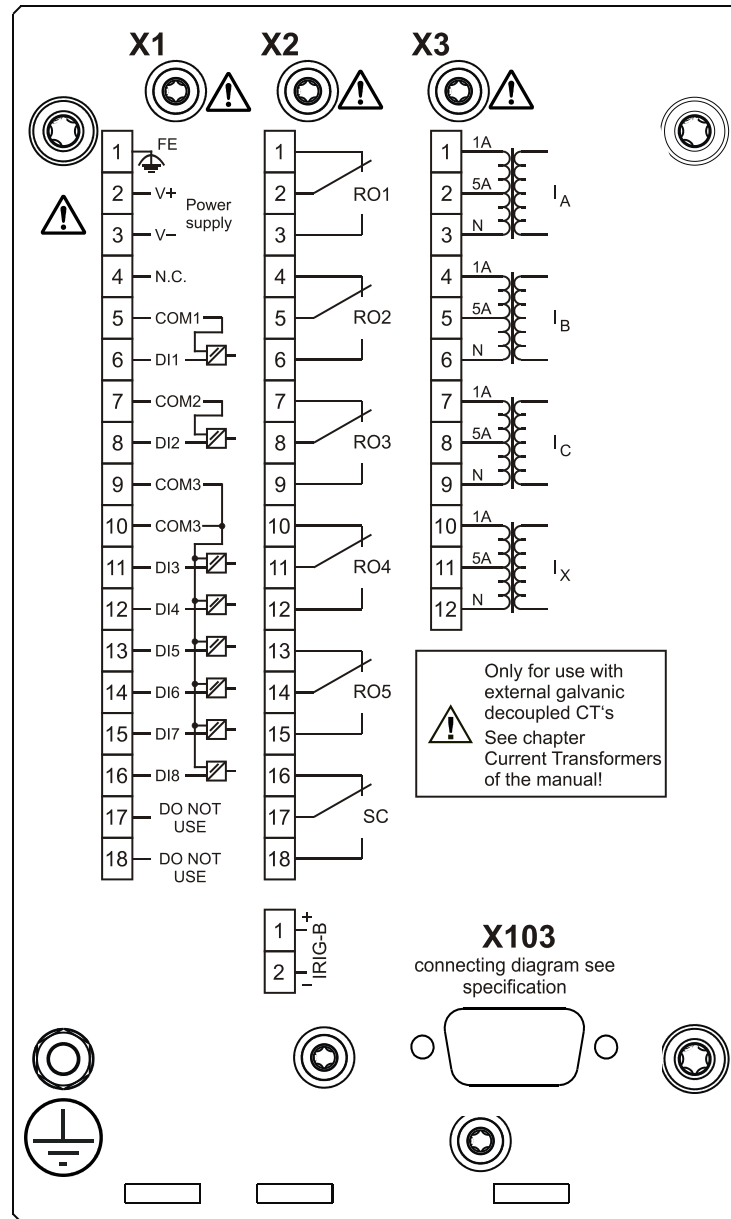

EDR-3000-2B0GB

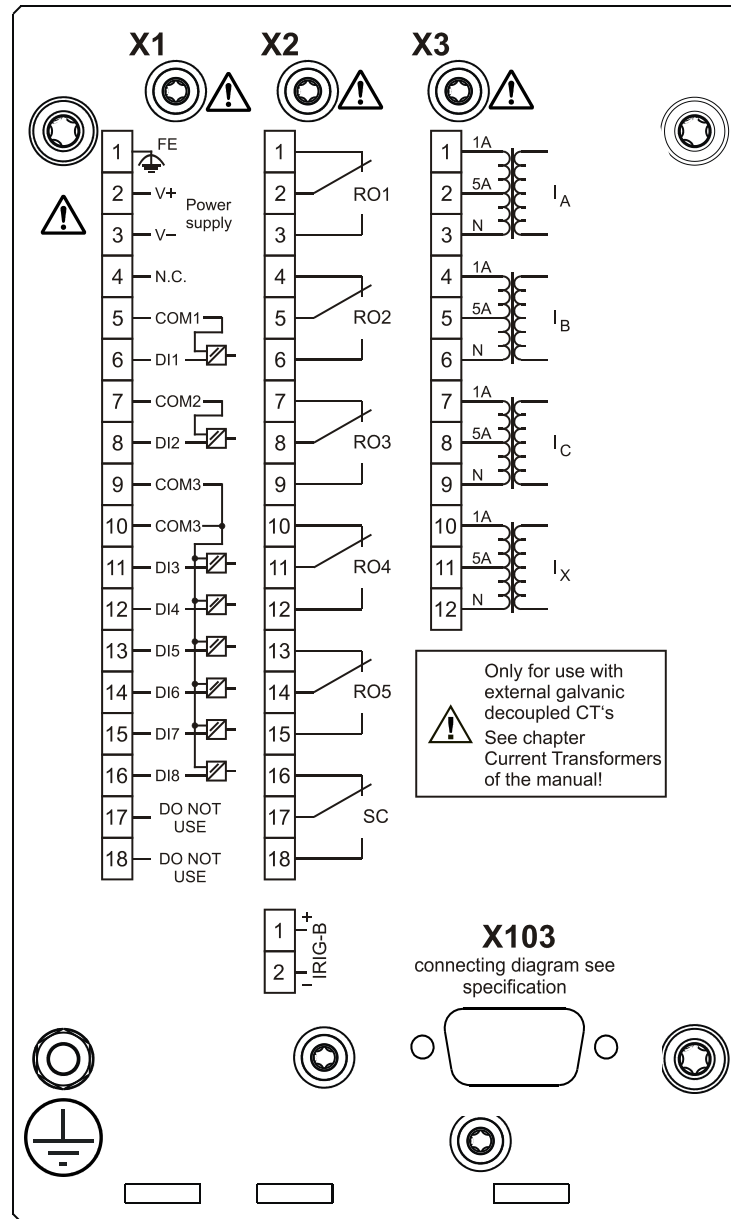

EDR-3000-2B0HA

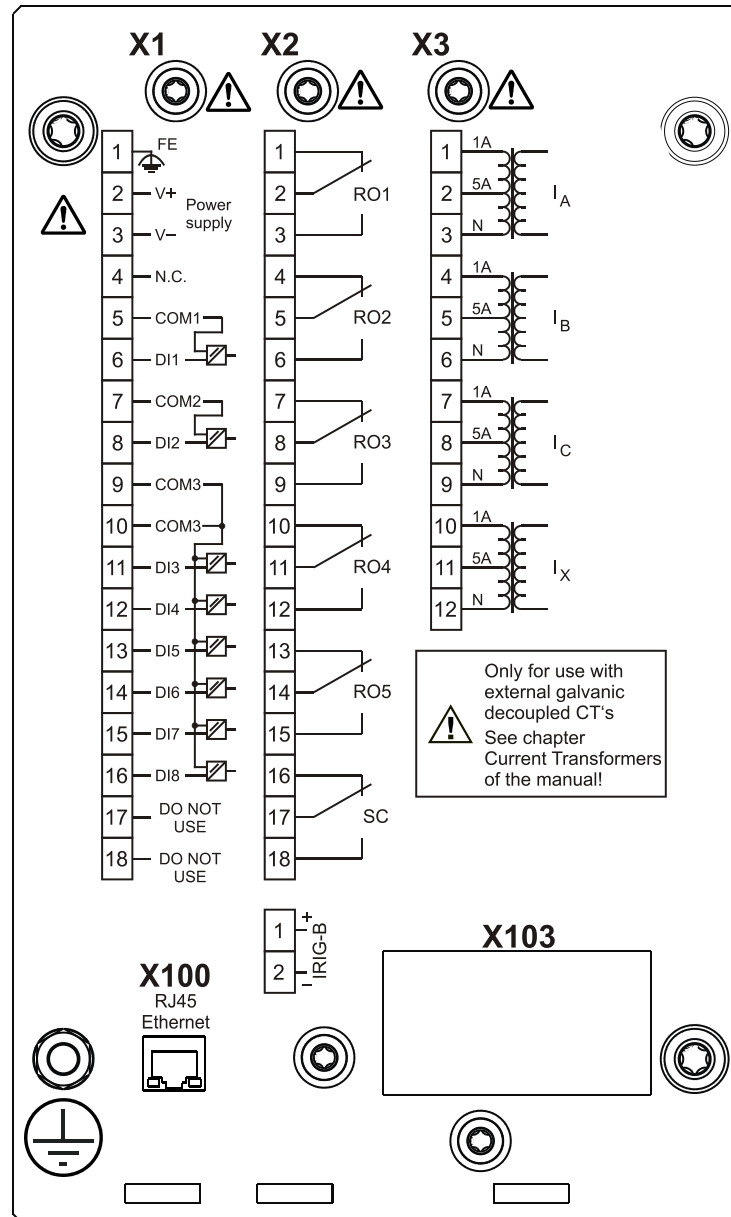

EDR-3000-2B0HB

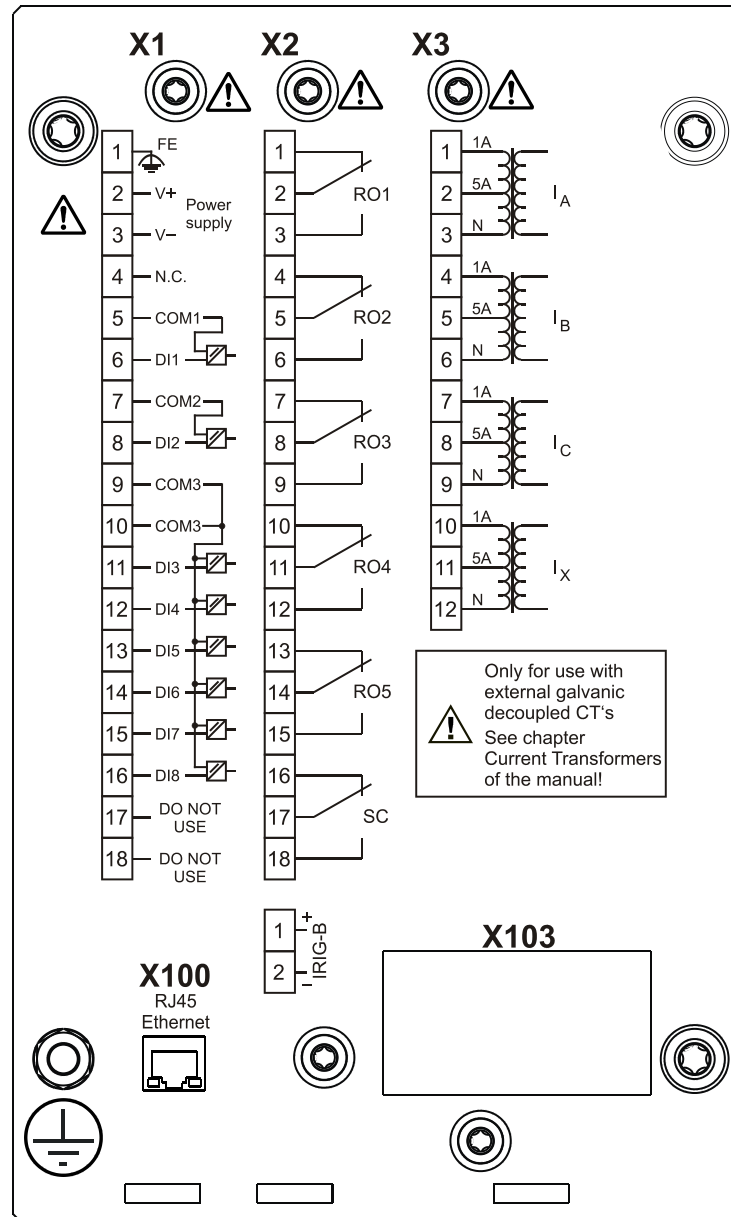

EDR-3000-2B01A

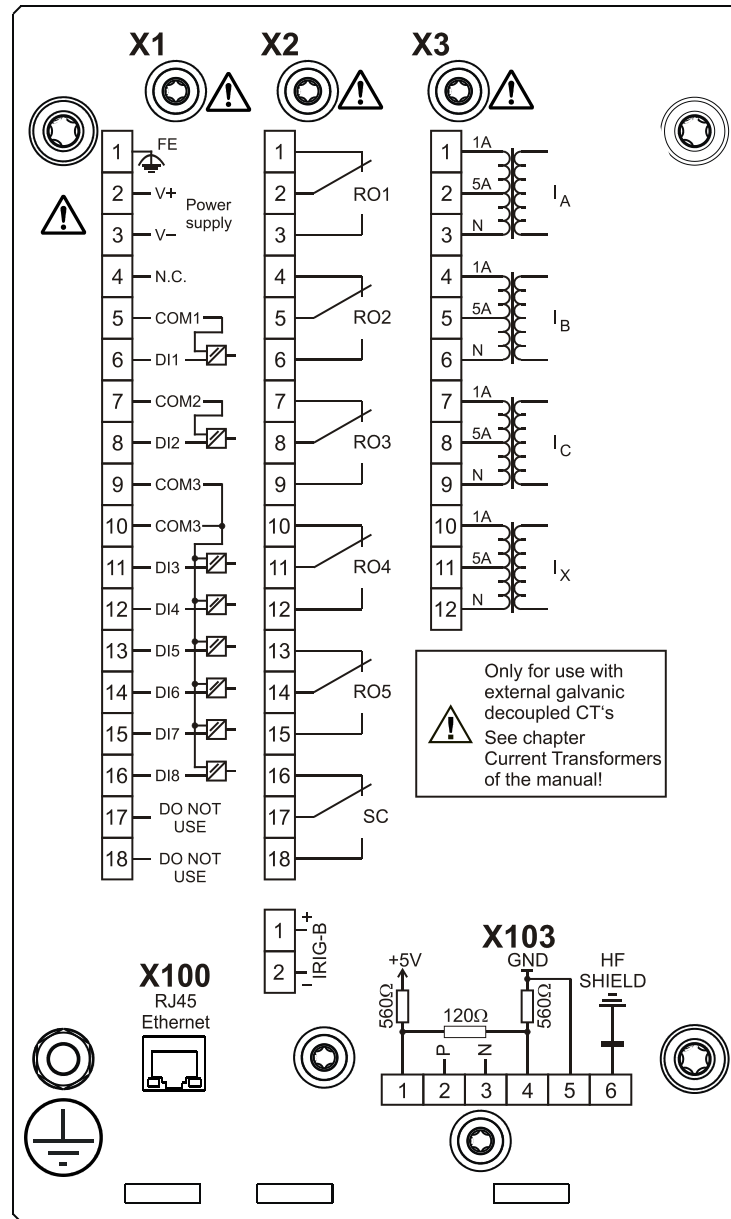

EDR-3000-2B0IB

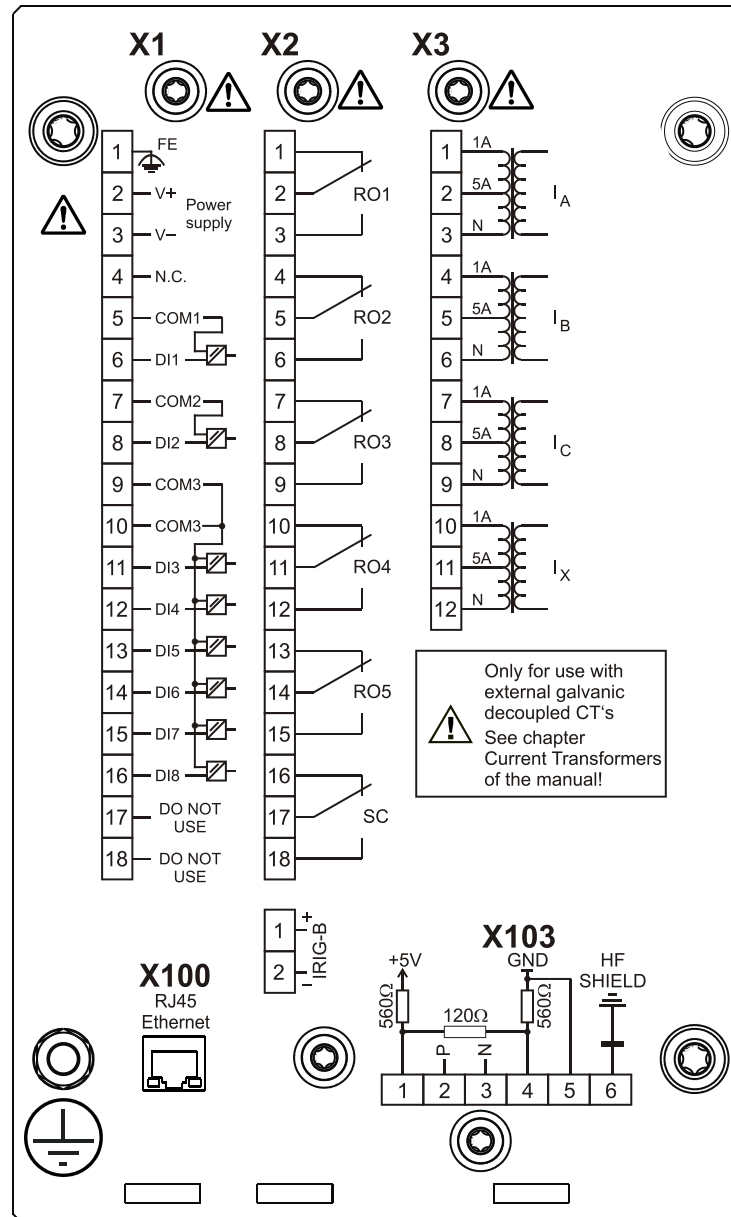

EDR-3000-2B0KA

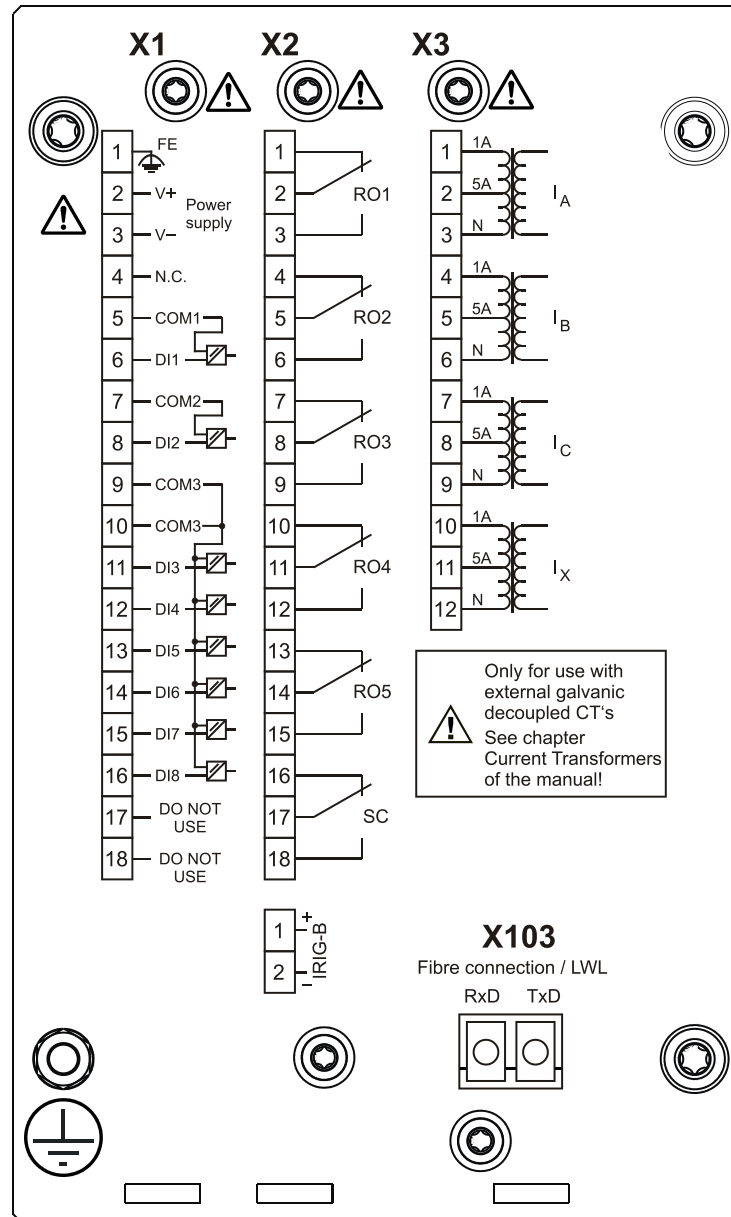

EDR-3000-2B0KB

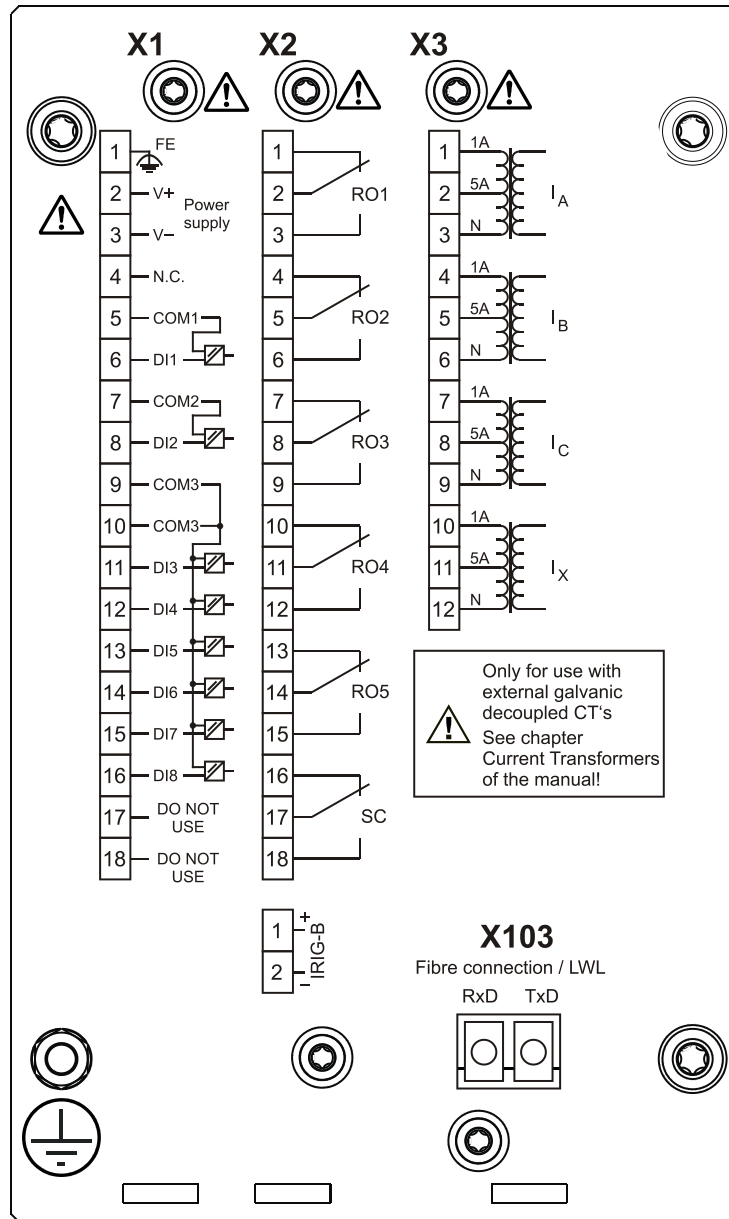

EDR-3000-2B0LA

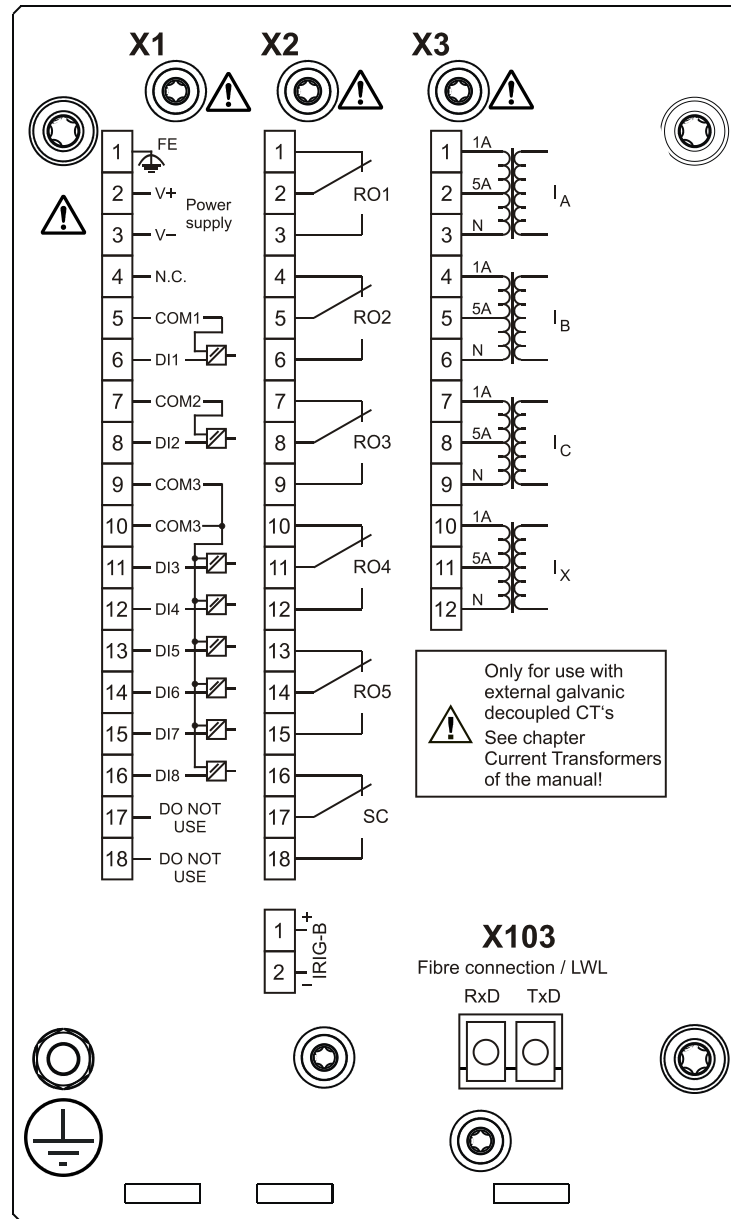

EDR-3000-2B0LB

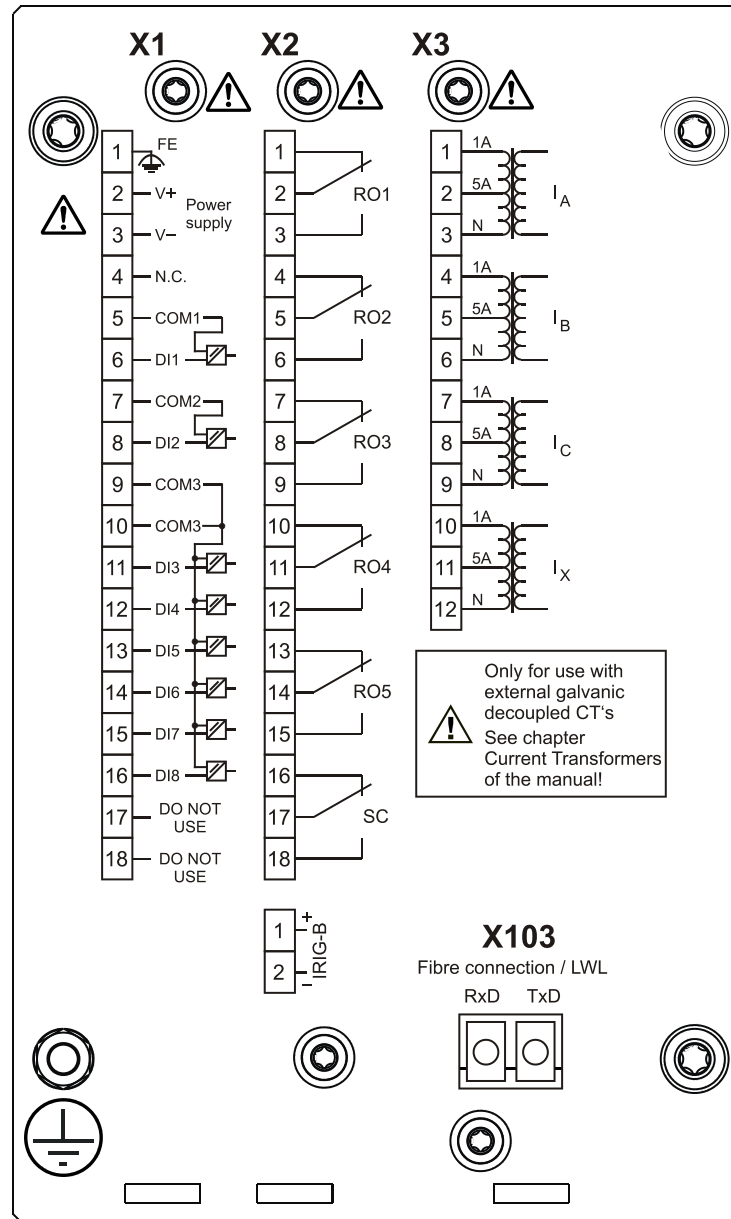

EDR-3000-2B1AA

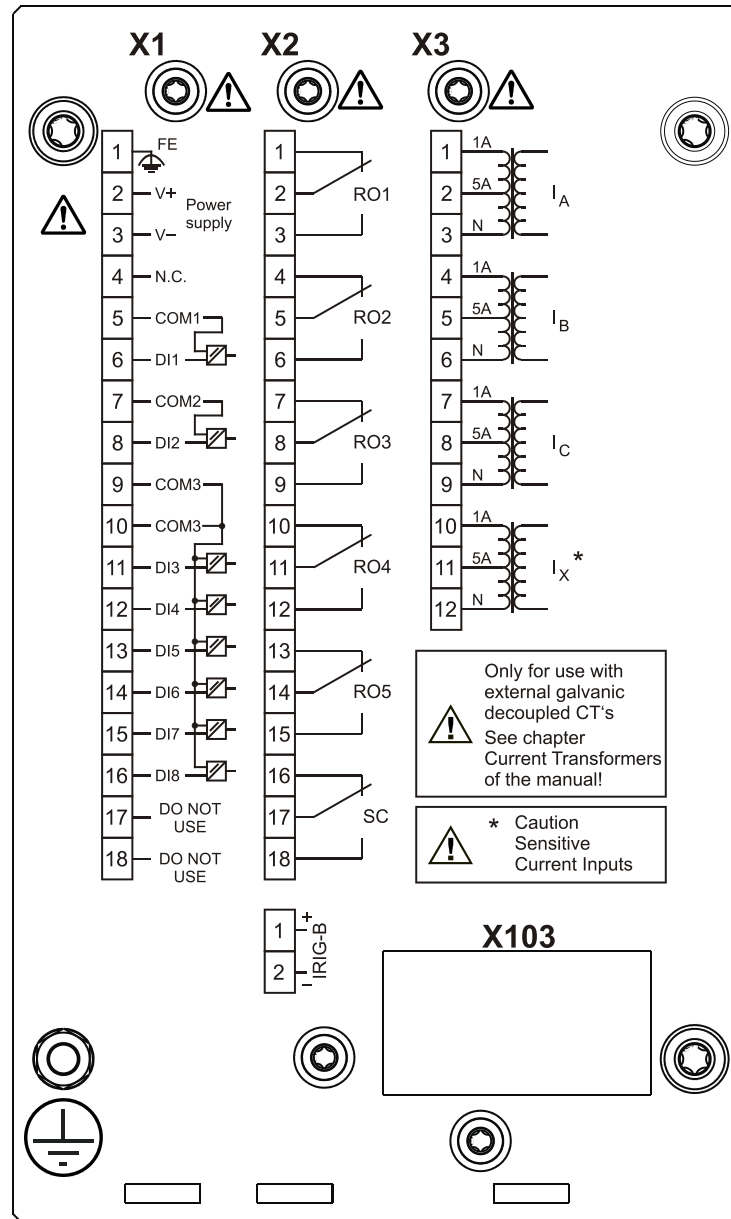

EDR-3000-2B1AB

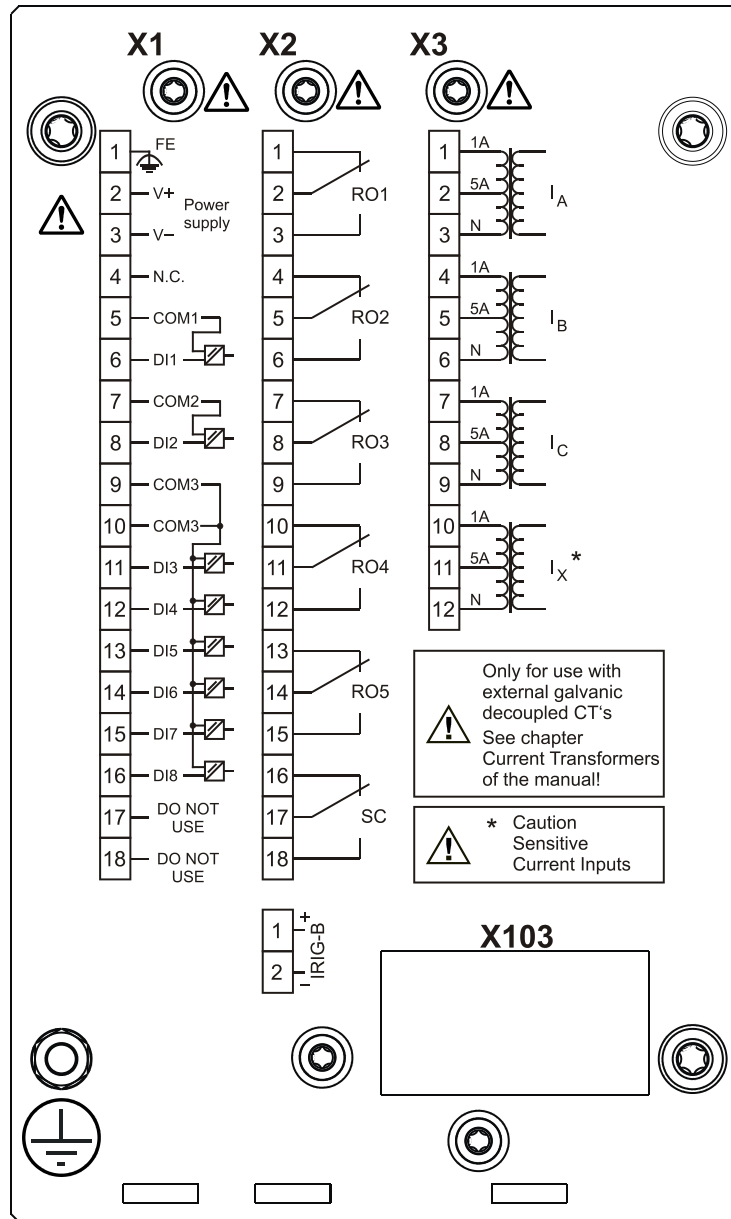

EDR-3000-2B1BA

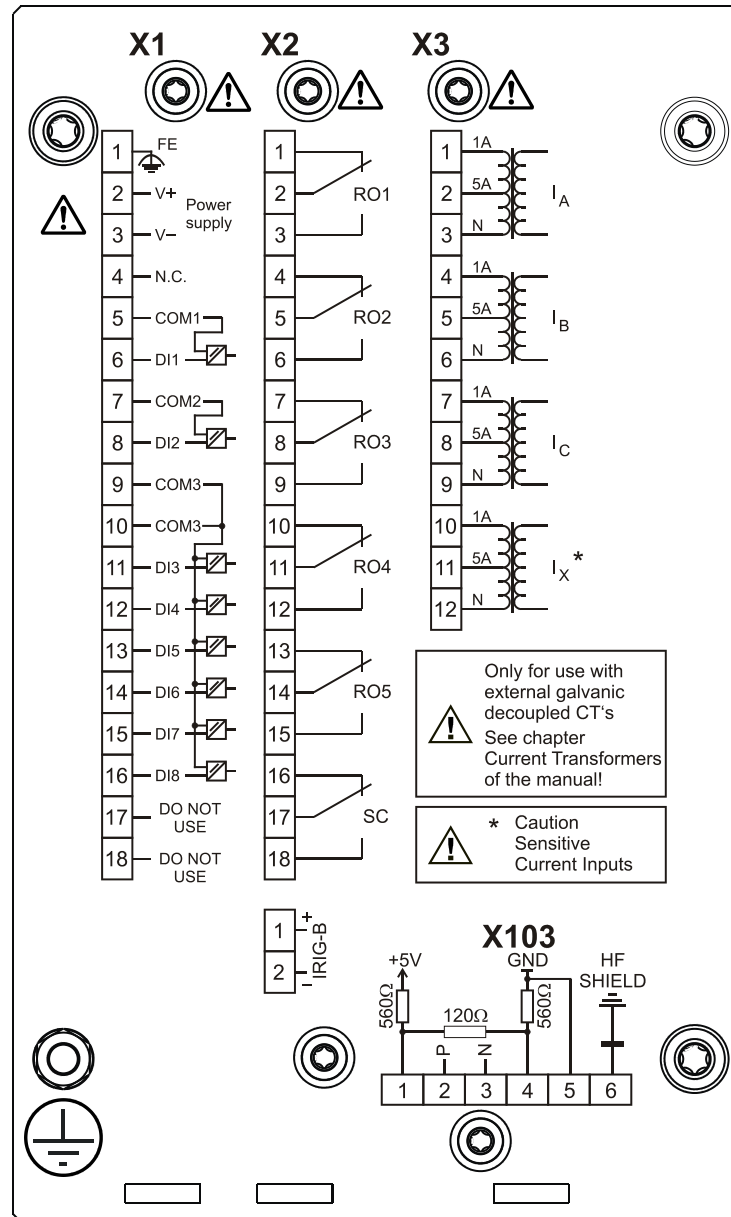

EDR-3000-2B1BB

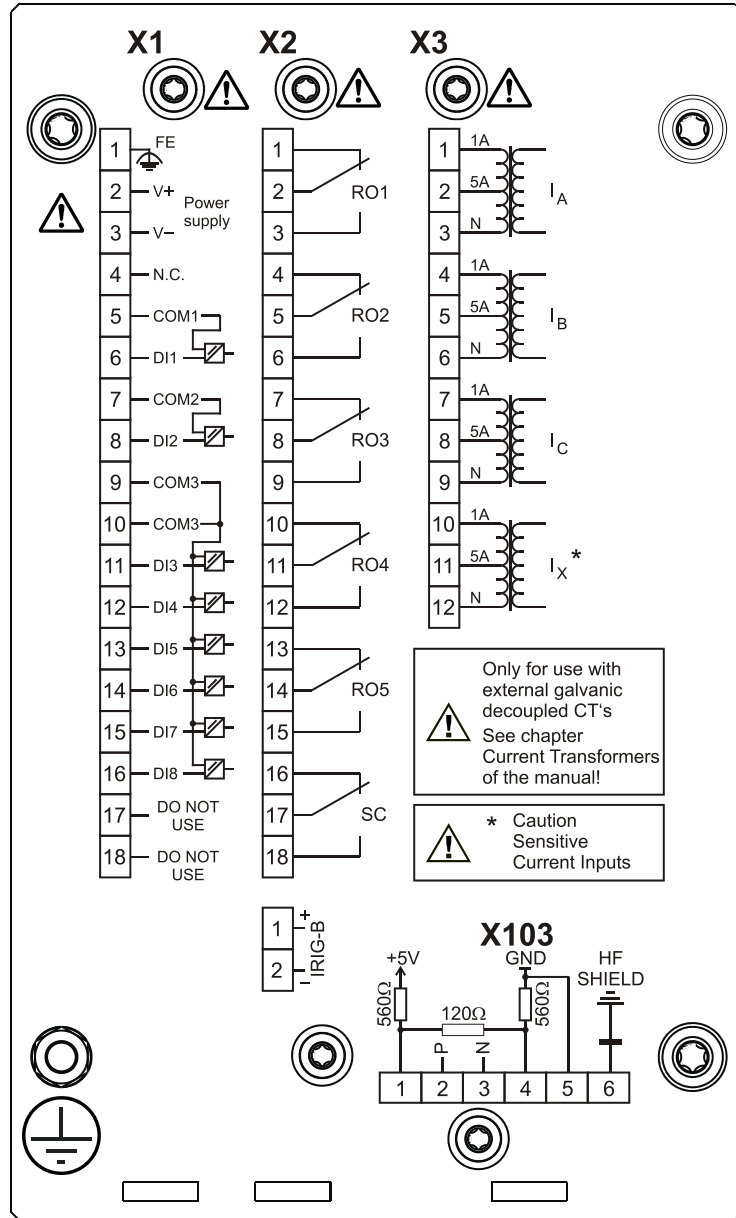

EDR-3000-2B1CA

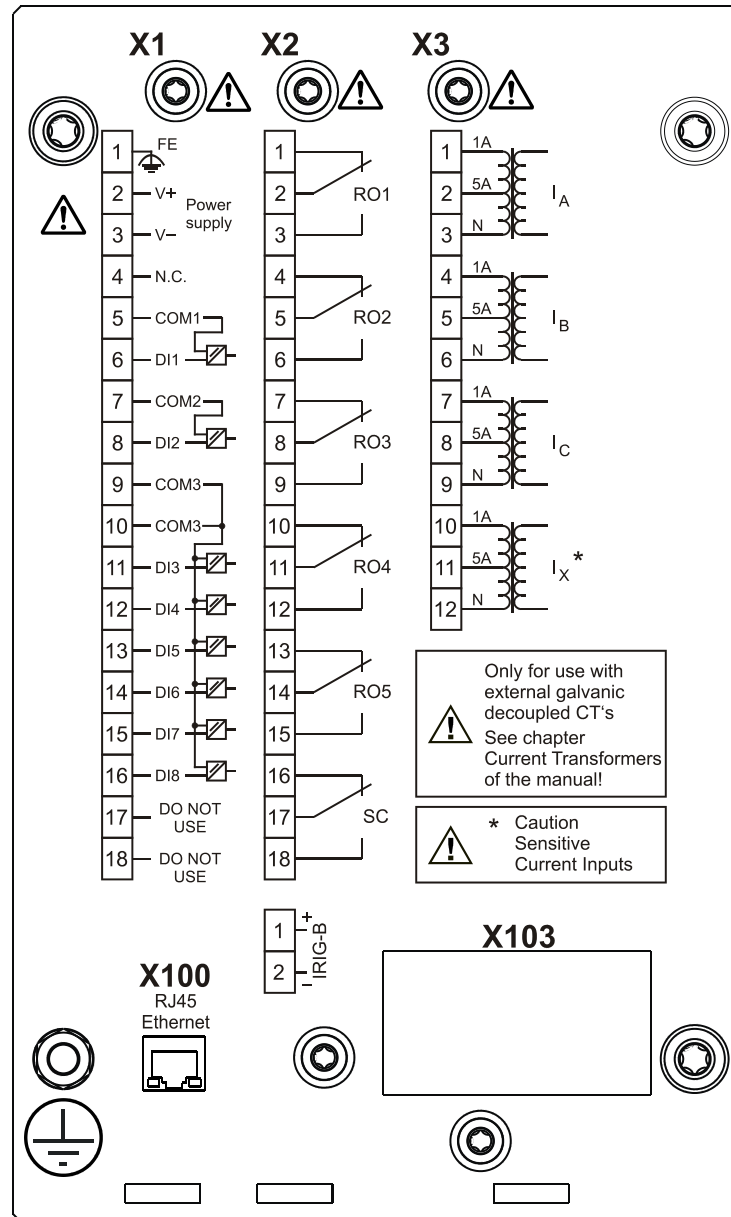

EDR-3000-2B1CB

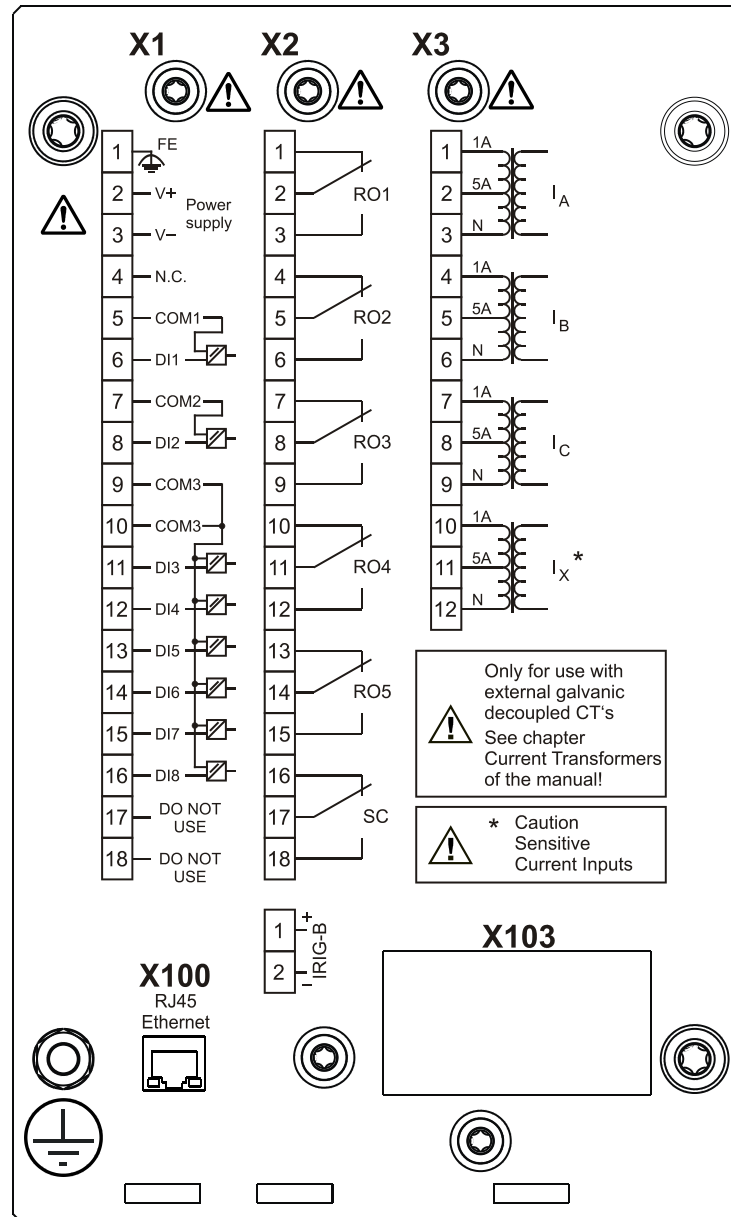

EDR-3000-2B1DA

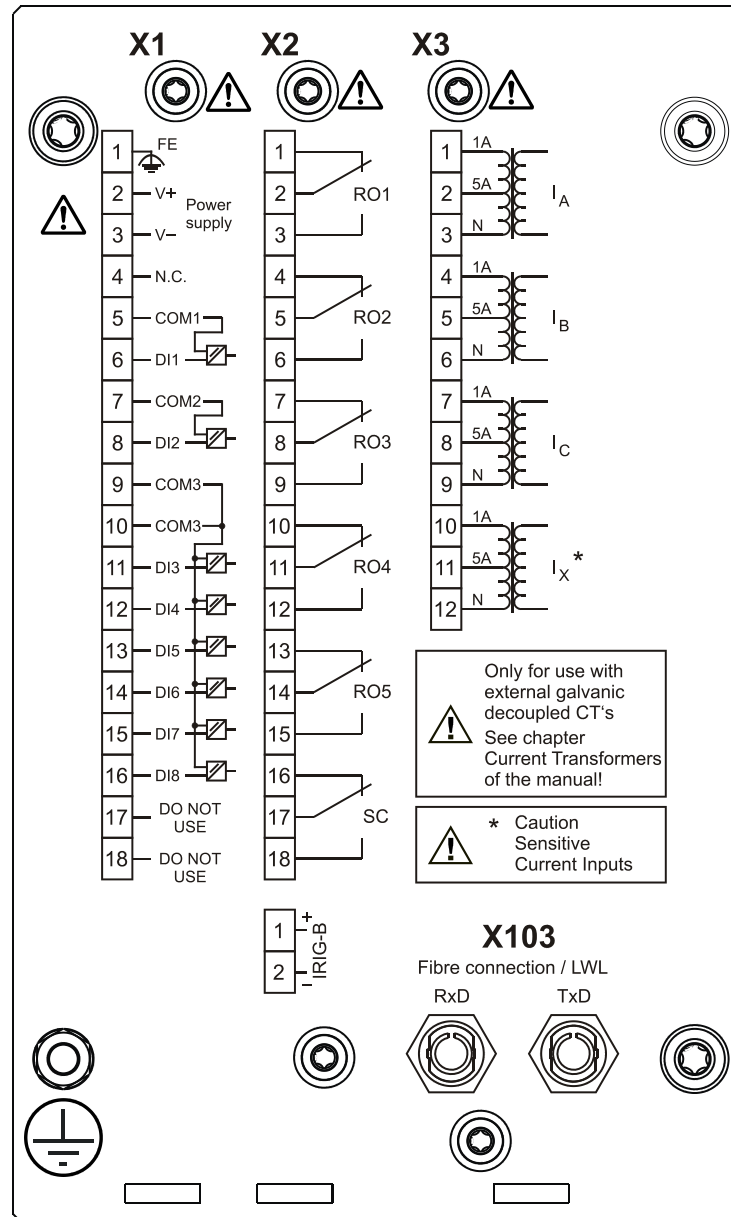

EDR-3000-2B1DB

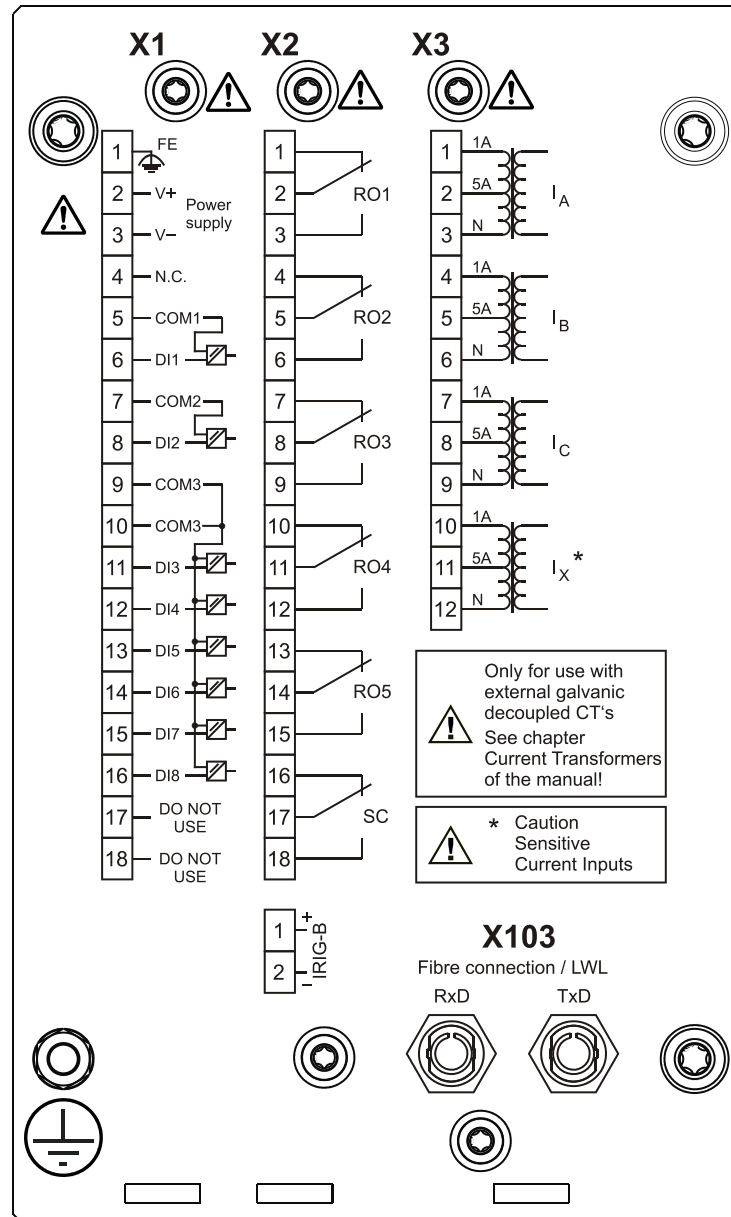

EDR-3000-2B1EA

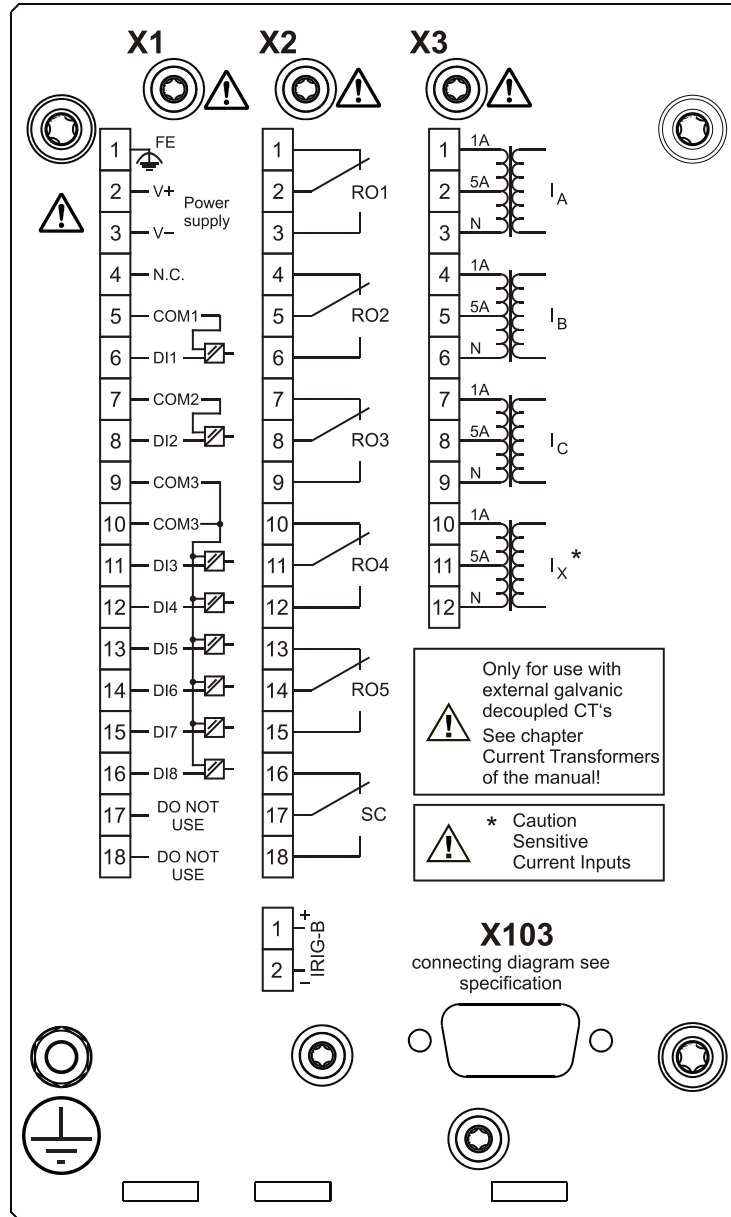

EDR-3000-2B1EB

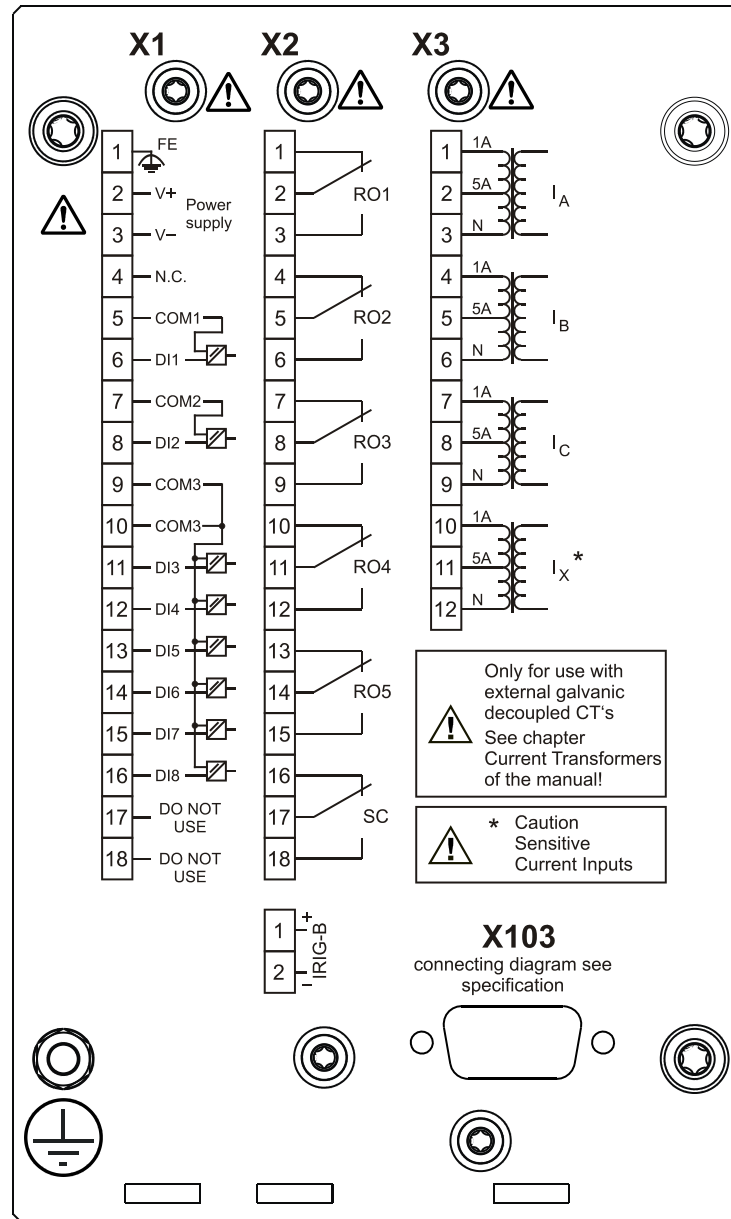

EDR-3000-2B1FA

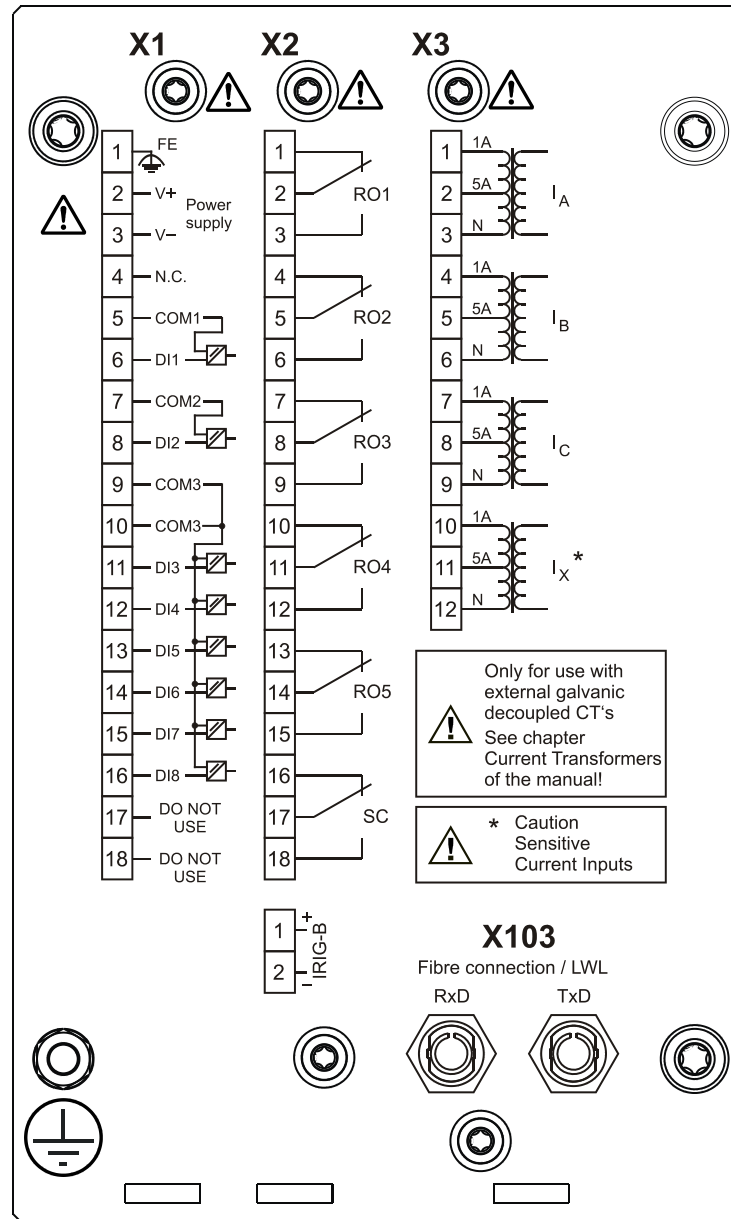

EDR-3000-2B1FB

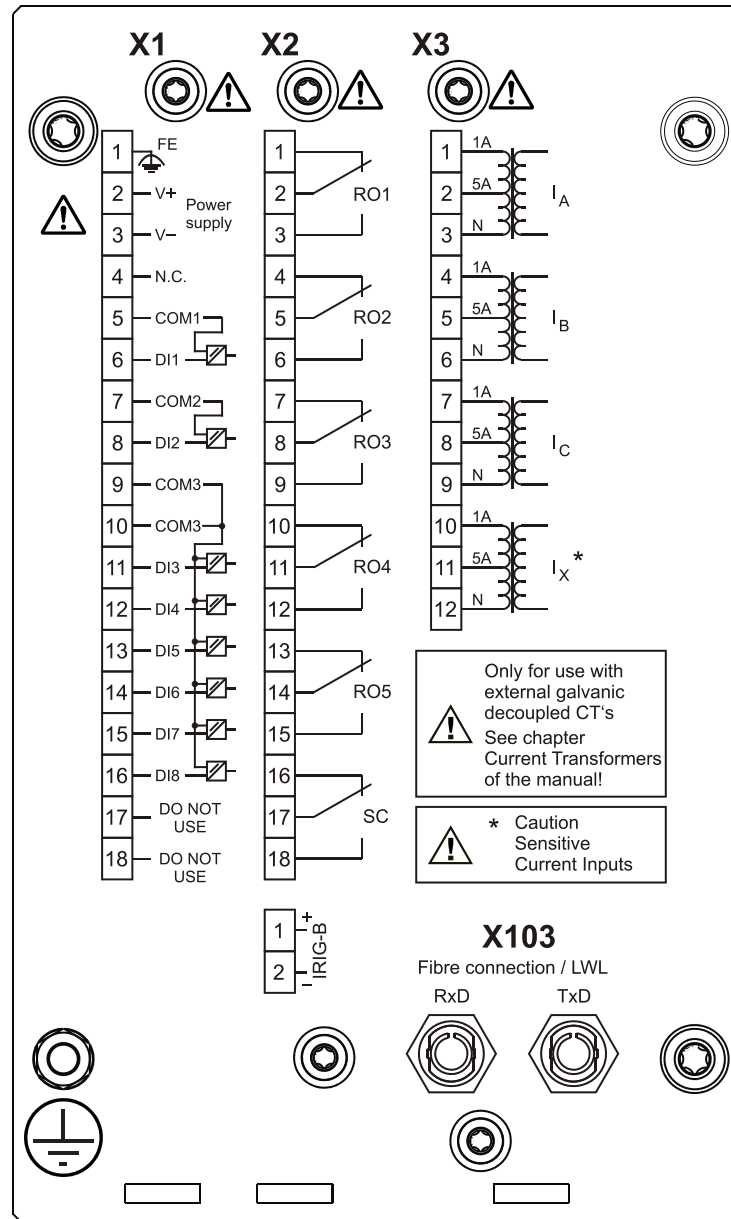

EDR-3000-2B1GA

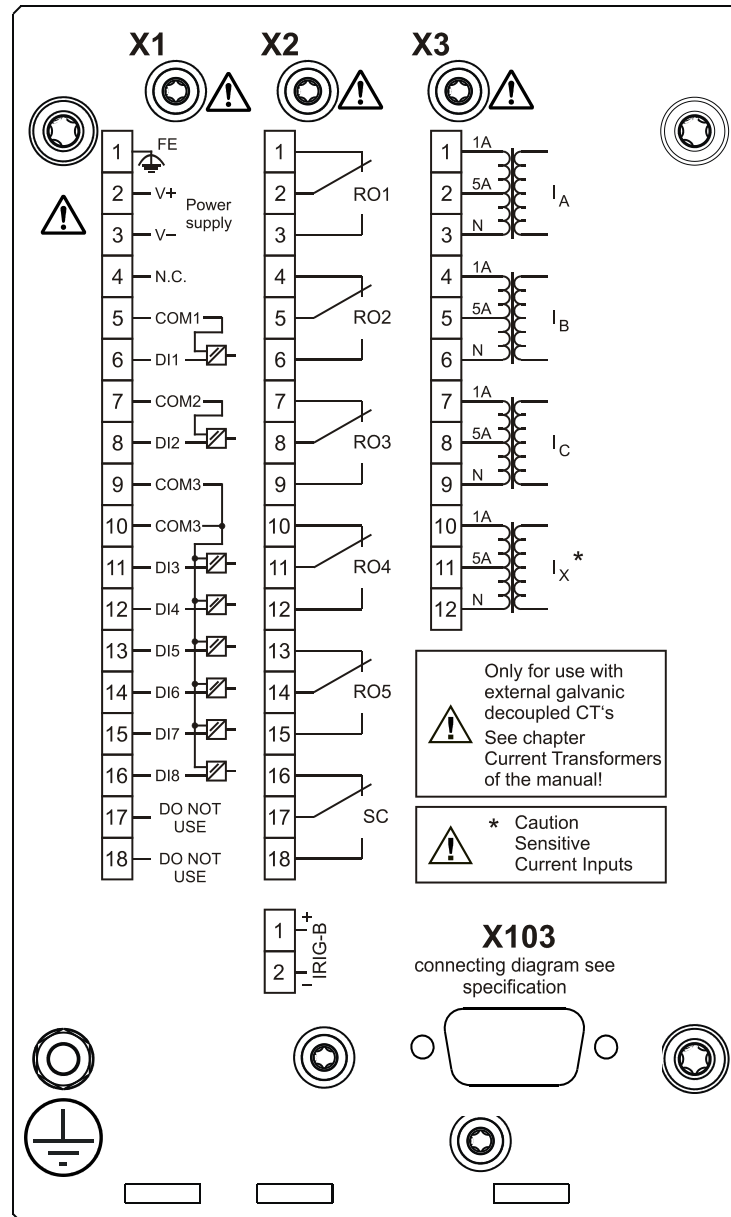

EDR-3000-2B1GB

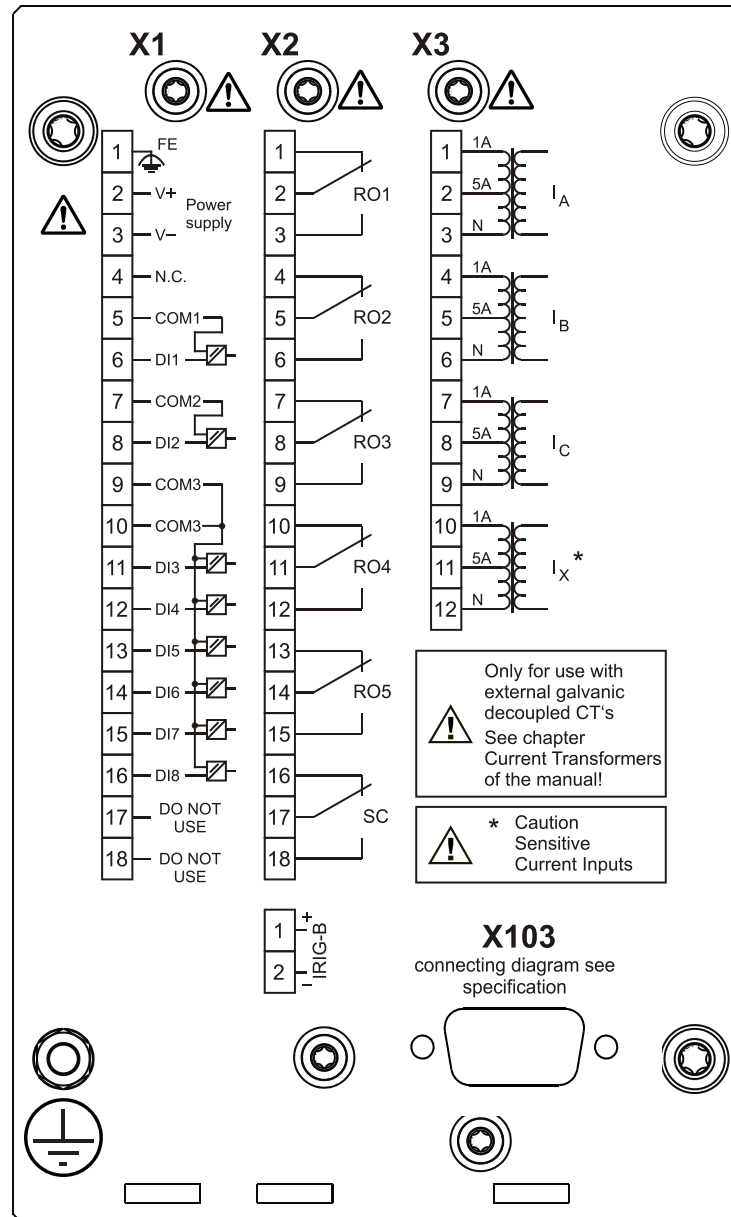

EDR-3000-2B1HA

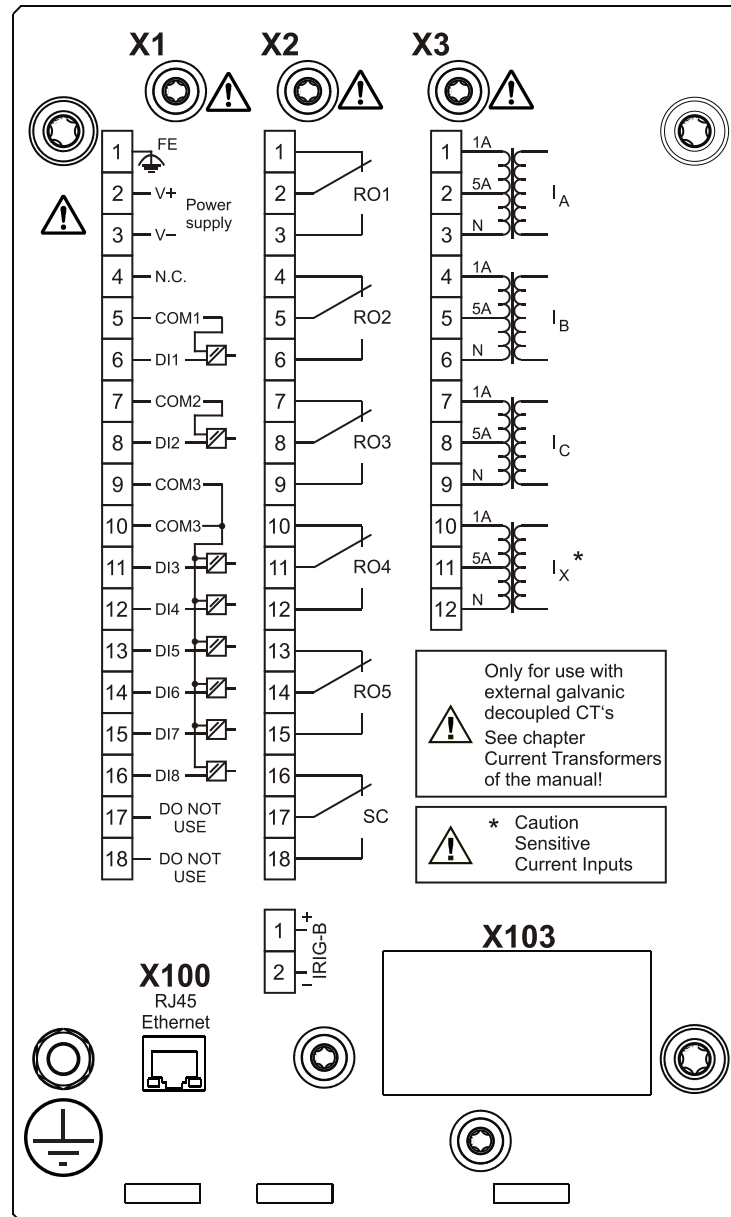

EDR-3000-2B1HB

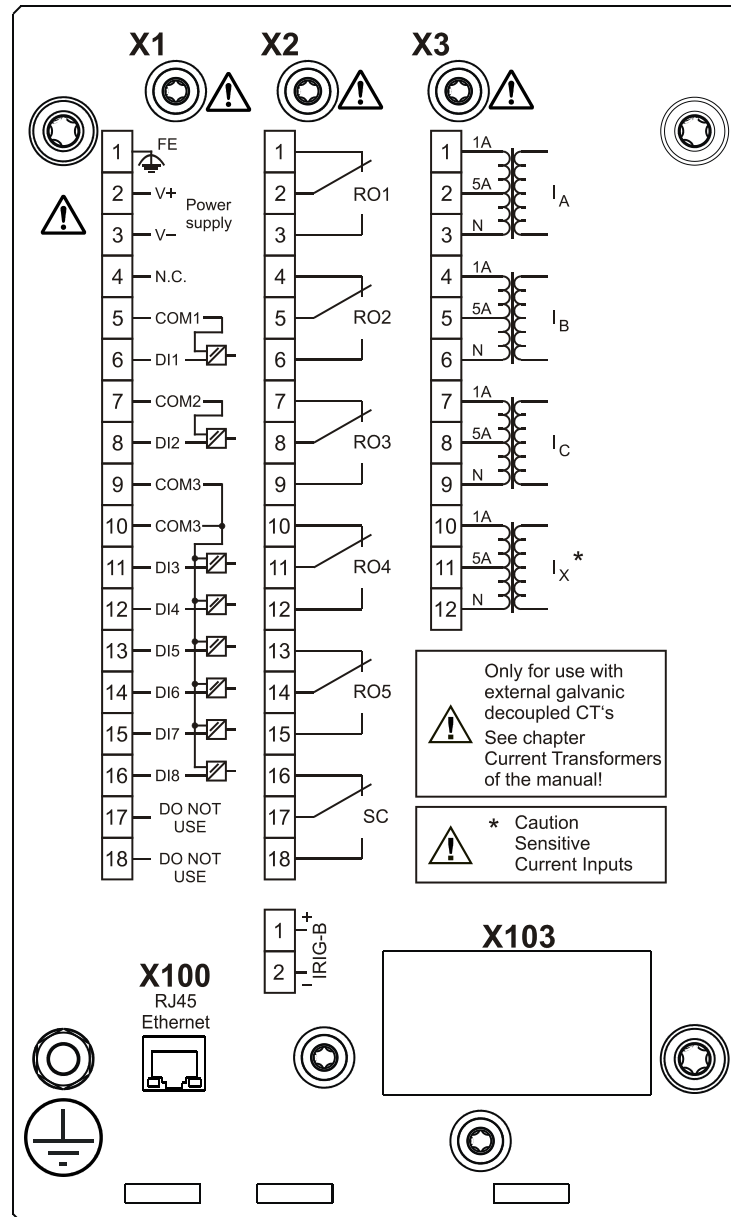

EDR-3000-2B1IA

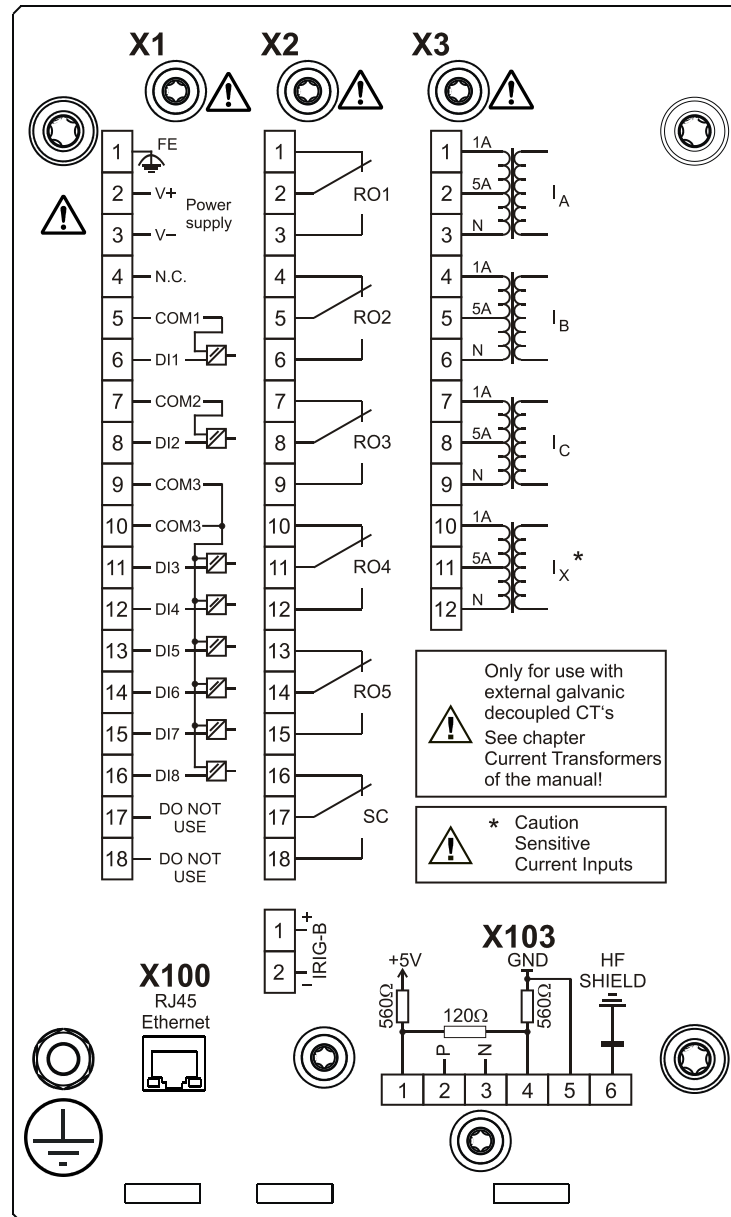

EDR-3000-2B1IB

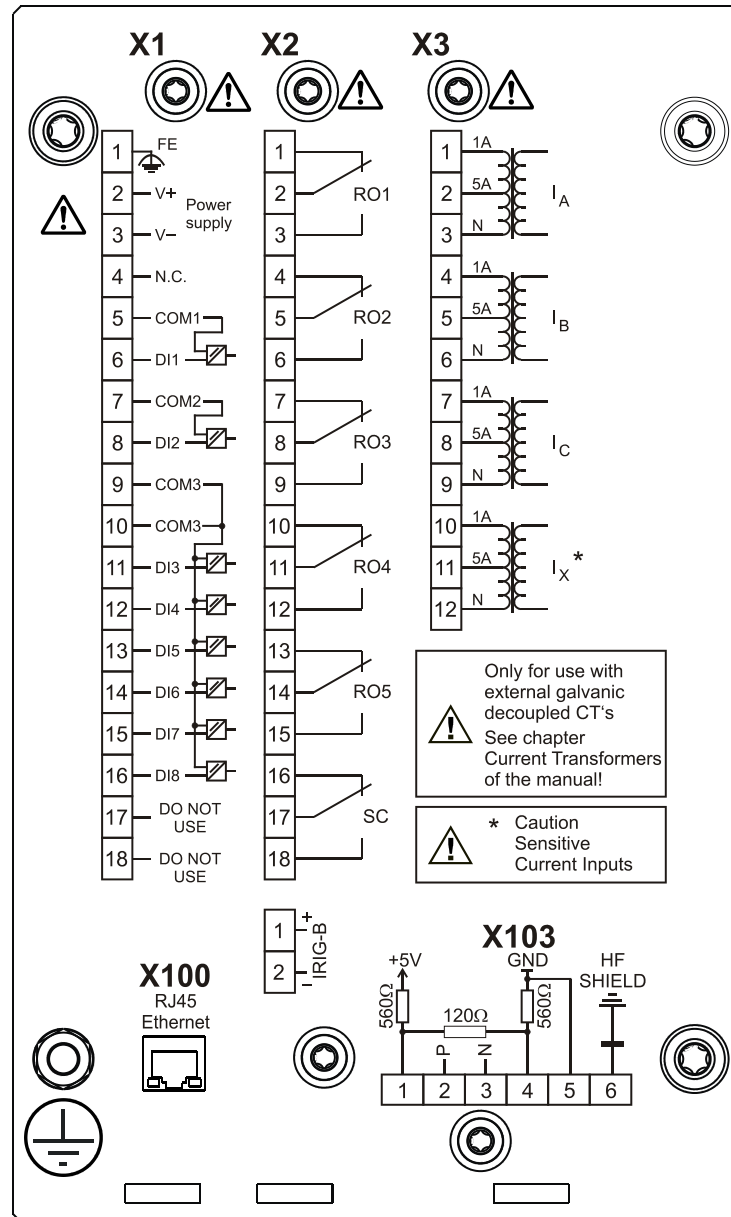

EDR-3000-2B1KA

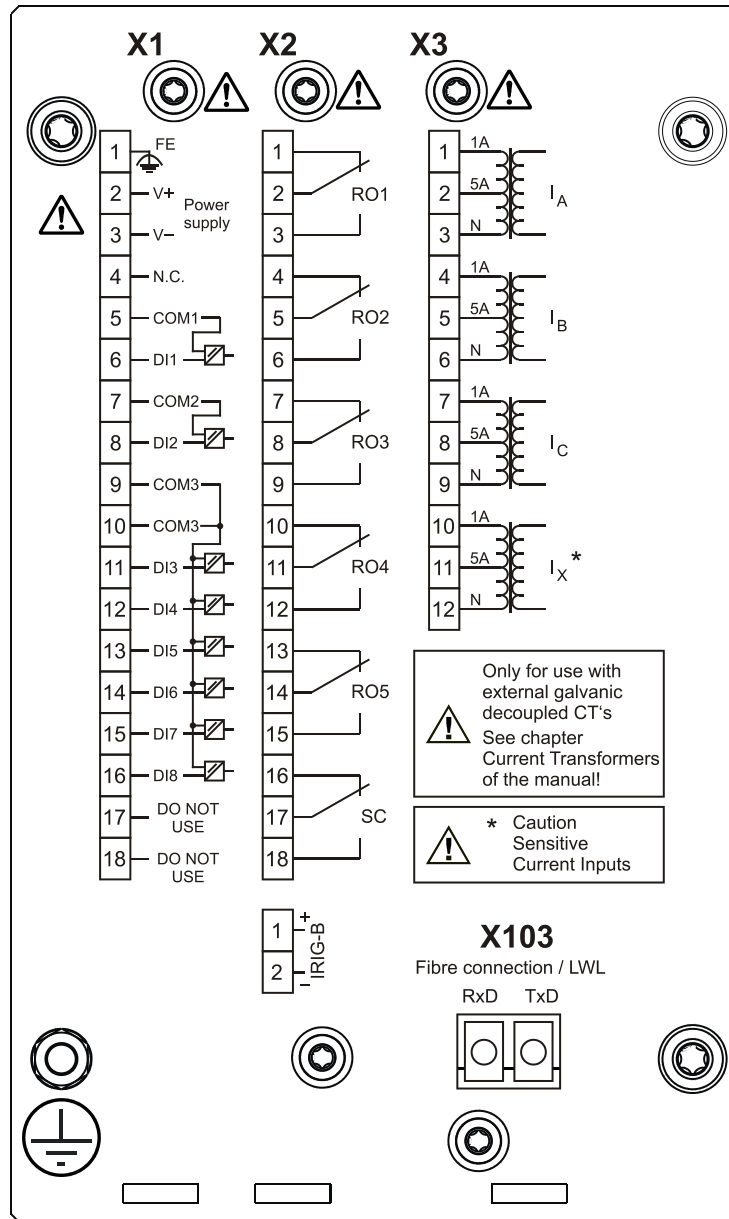

EDR-3000-2B1KB

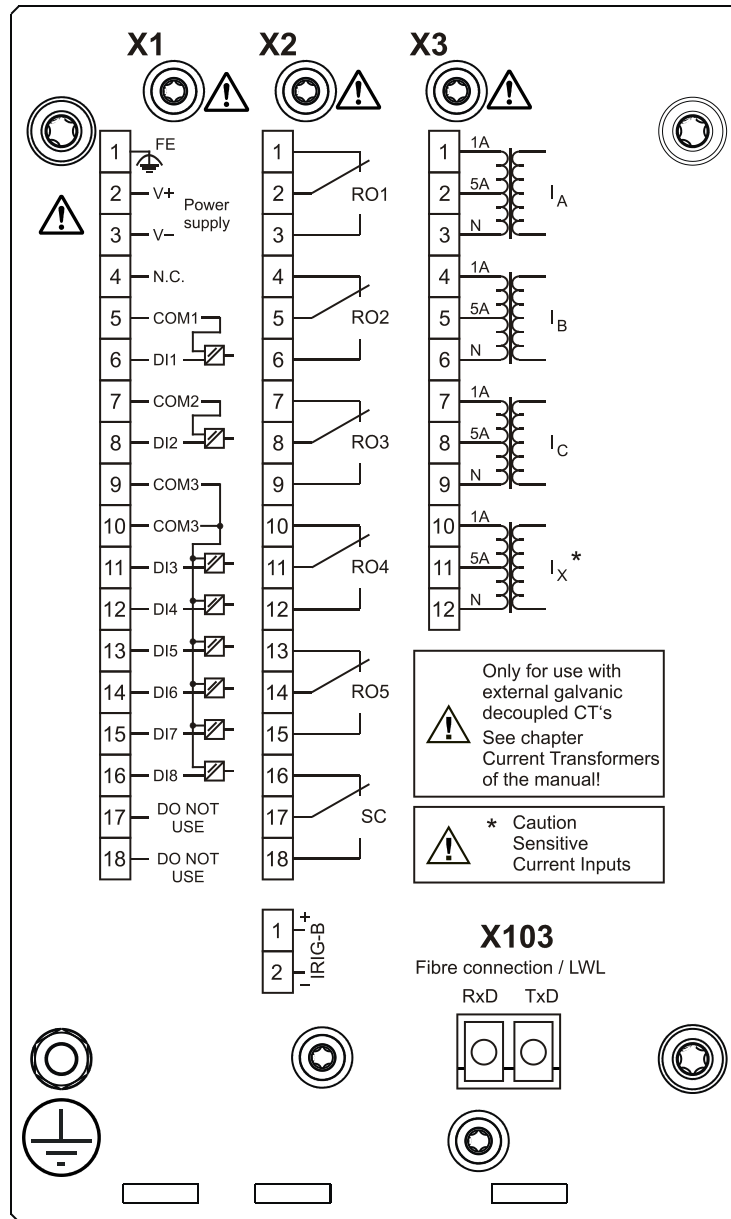

EDR-3000-2B1LA

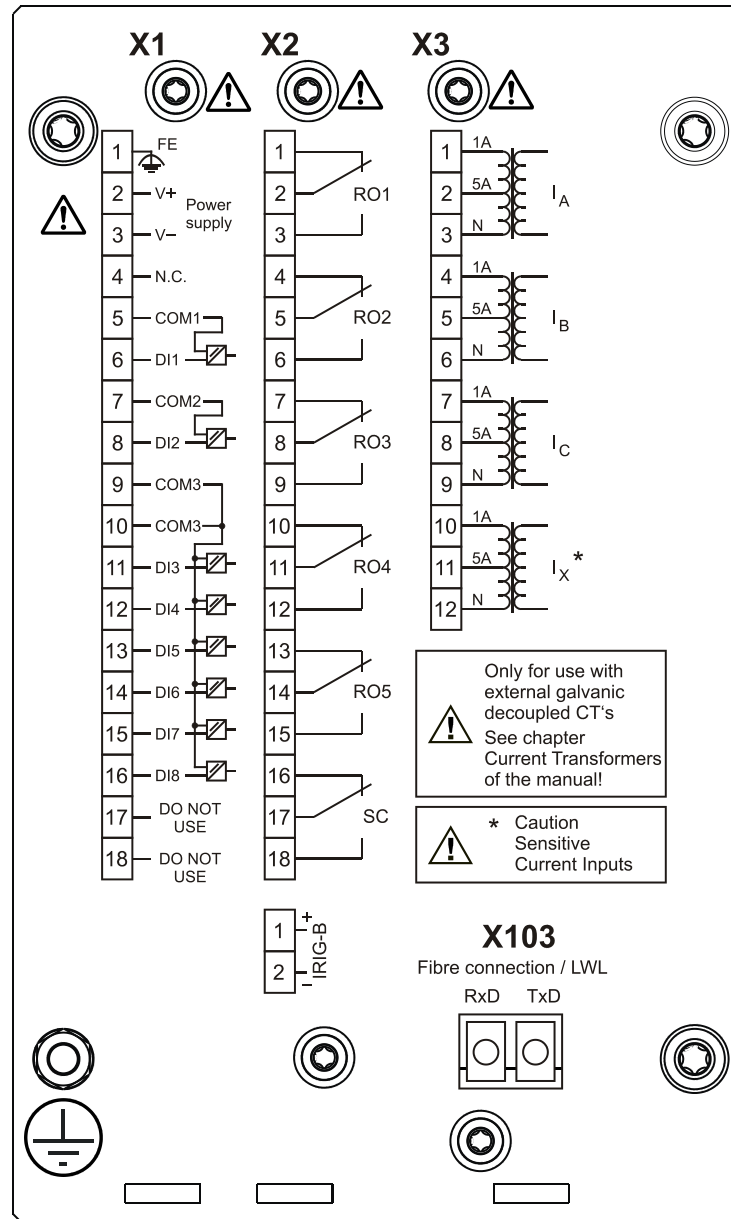

EDR-3000-2B1LB

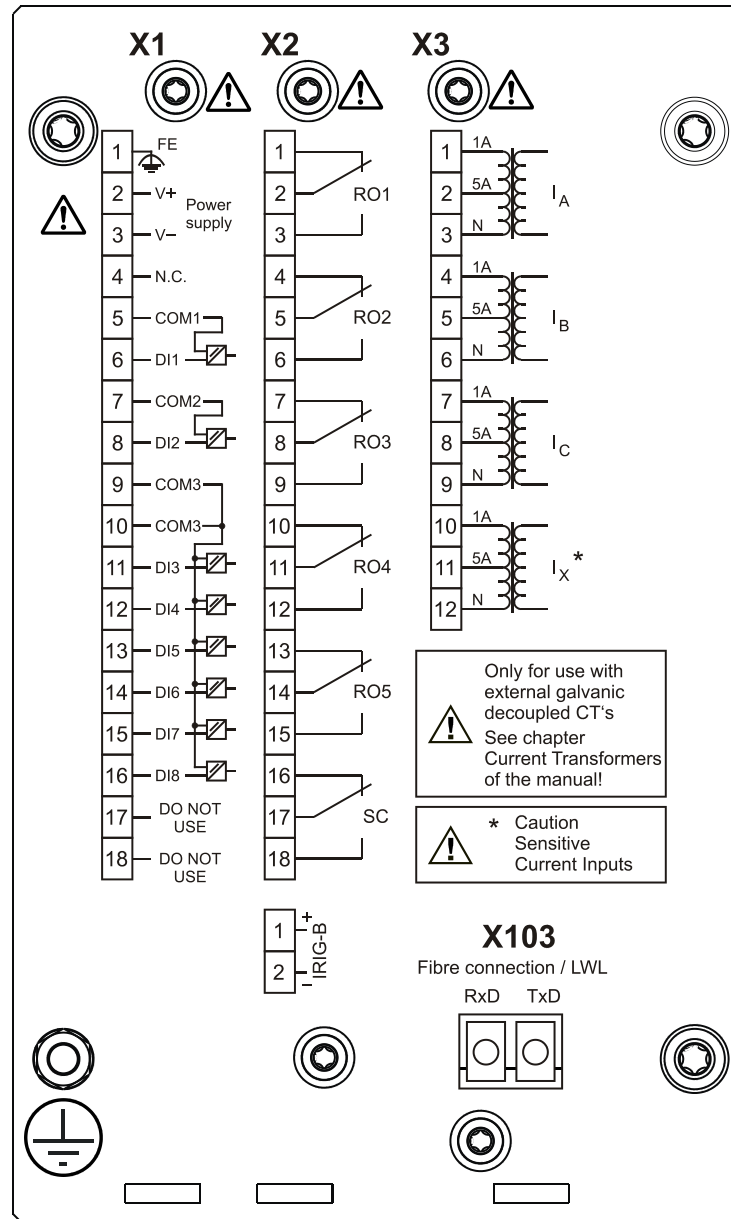

EDR-3000-2C0AA

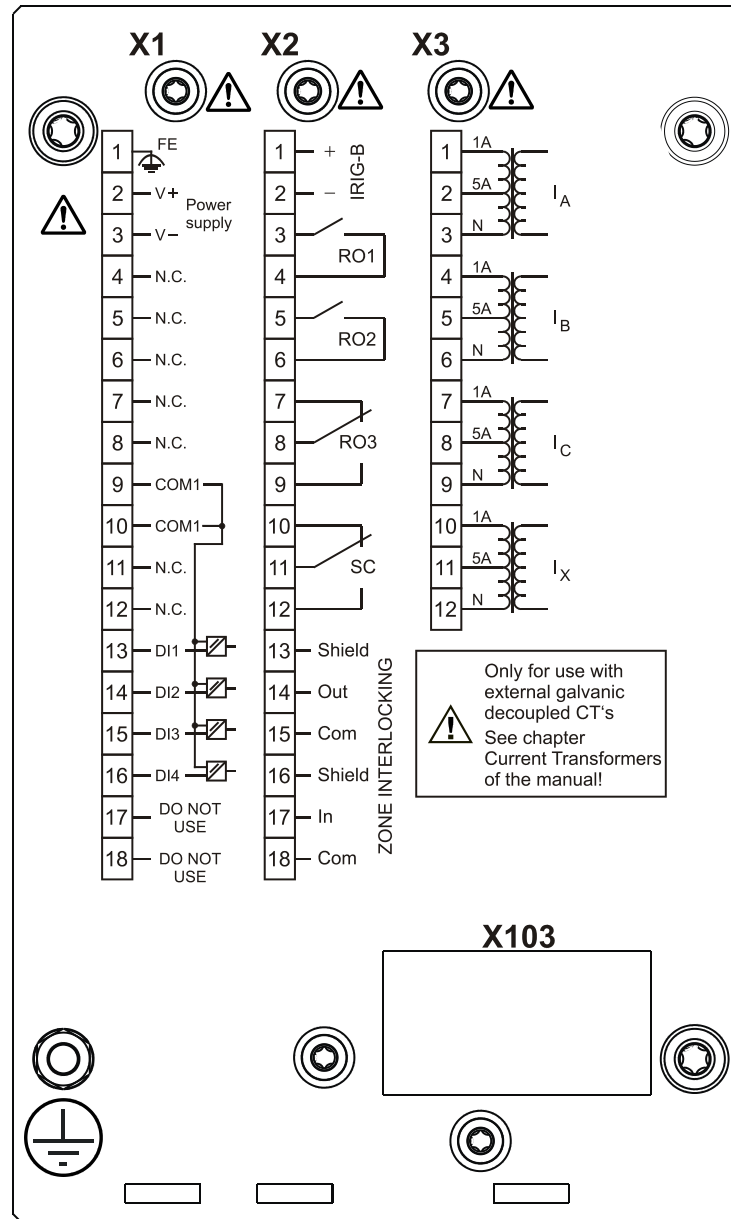

EDR-3000-2C0AB

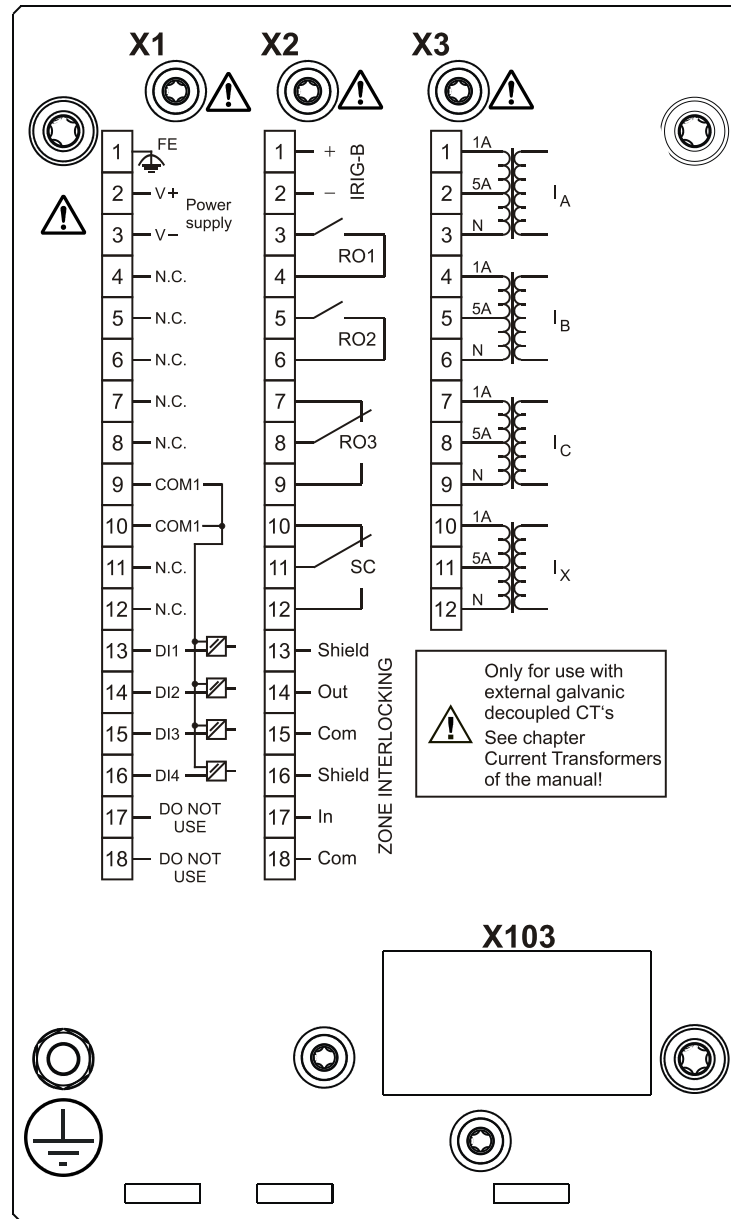

EDR-3000-2C0BA

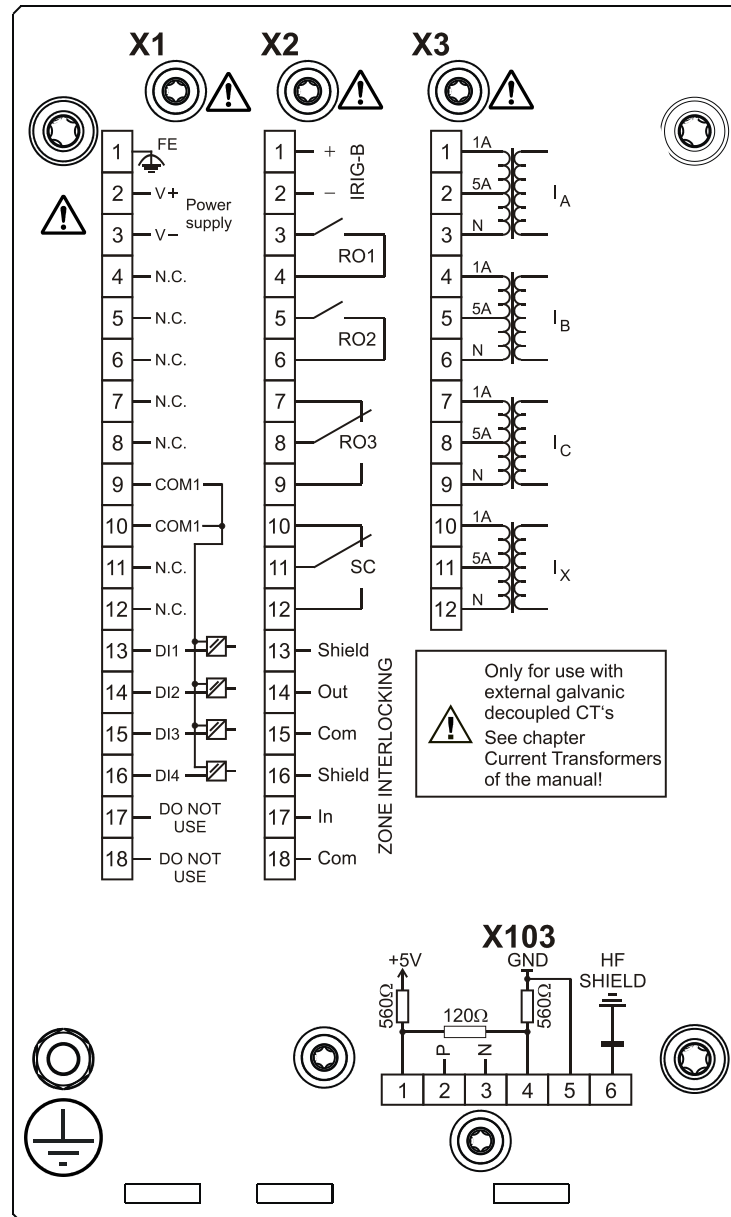

EDR-3000-2C0BB

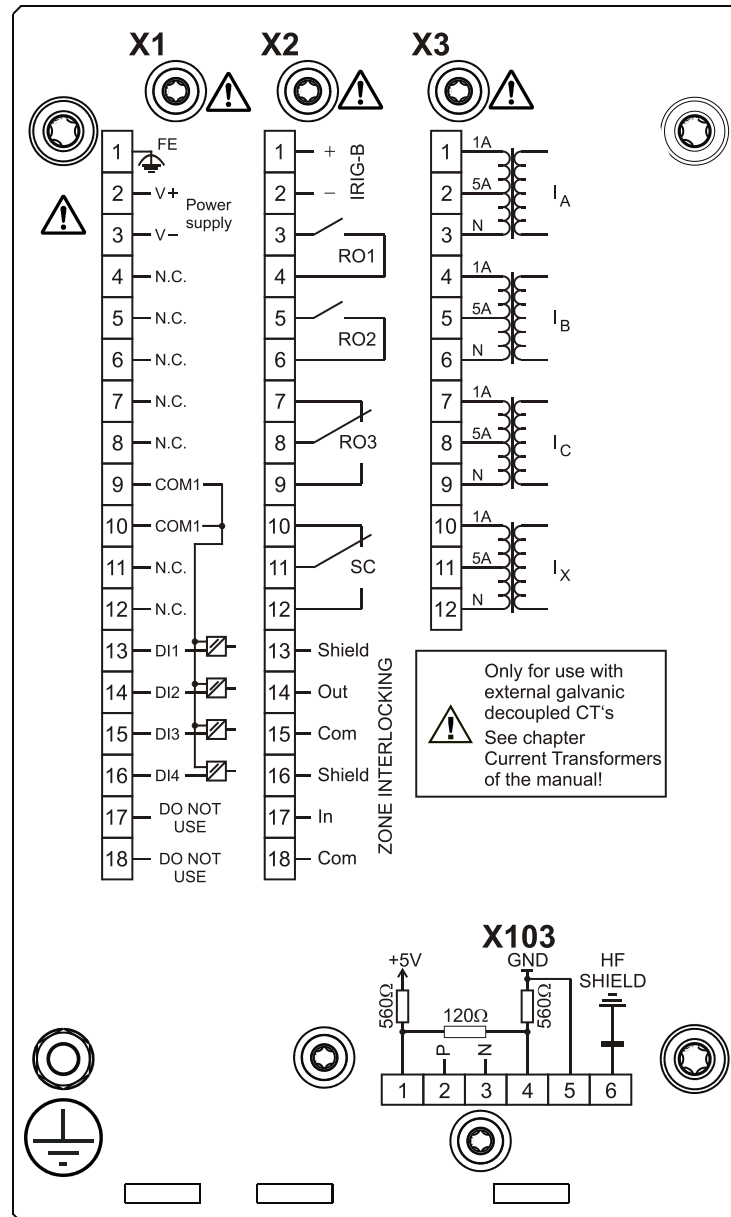

EDR-3000-2C0CA

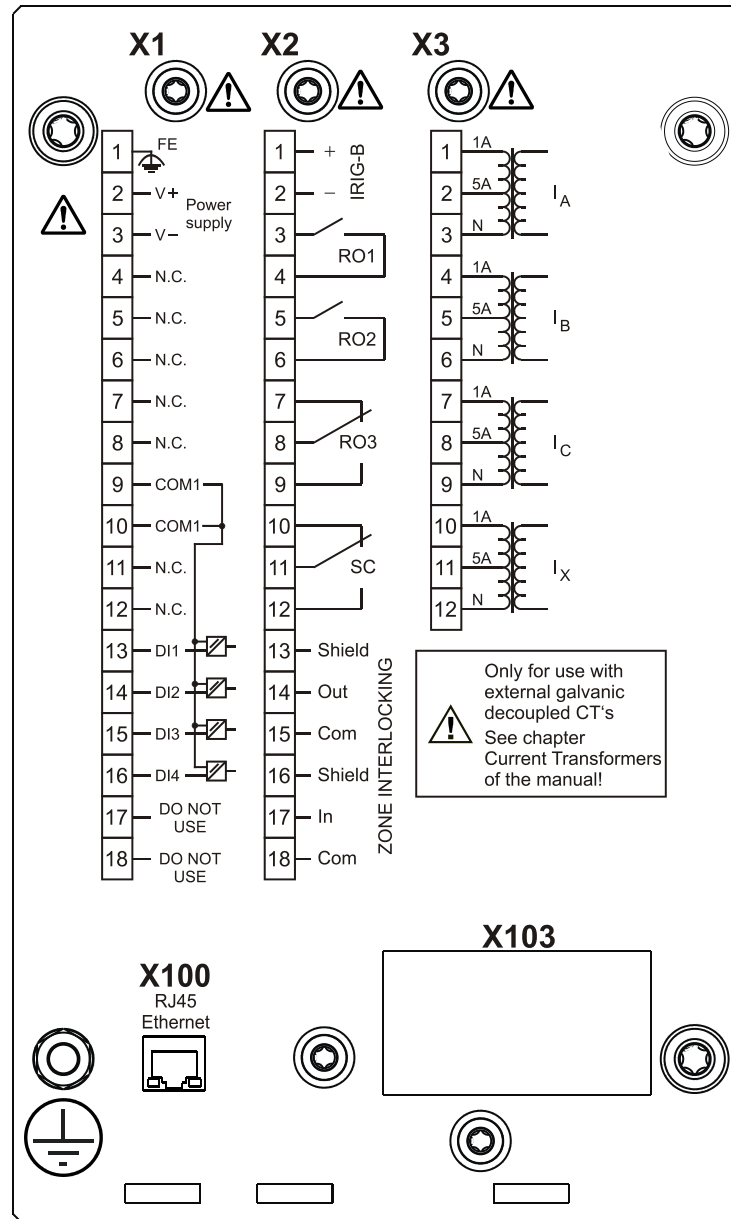

EDR-3000-2C0CB

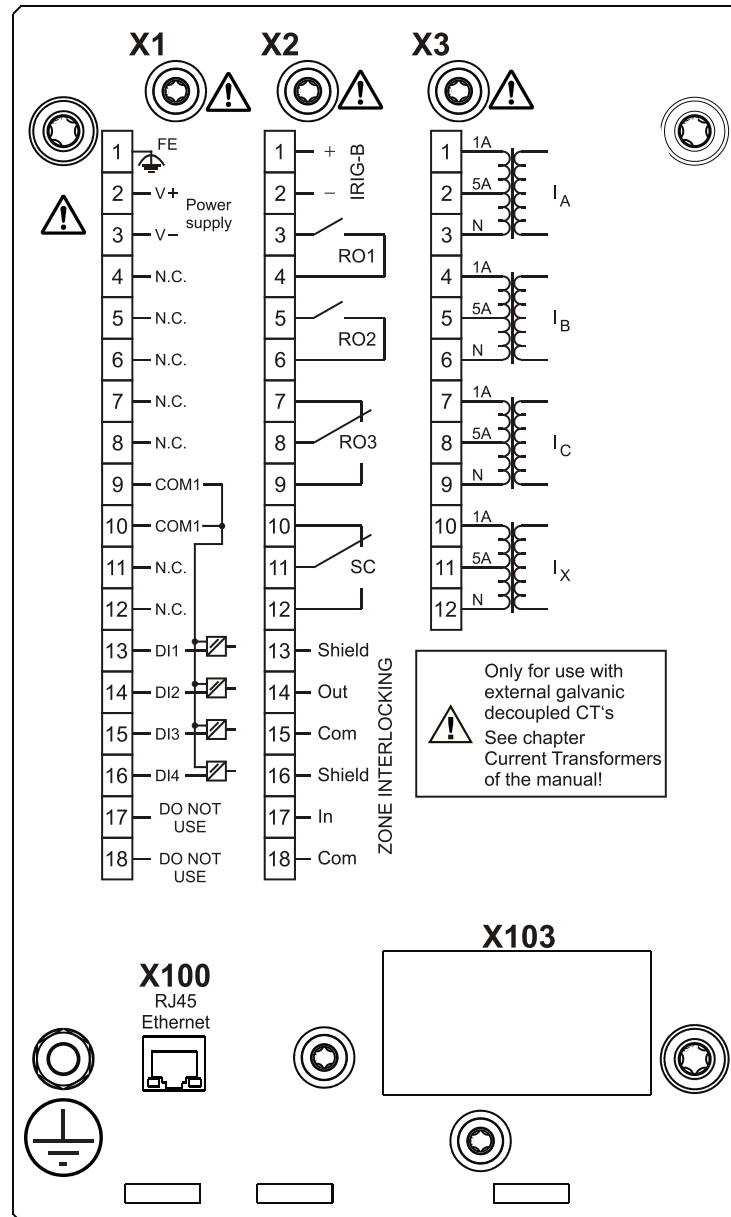

EDR-3000-2C0DA

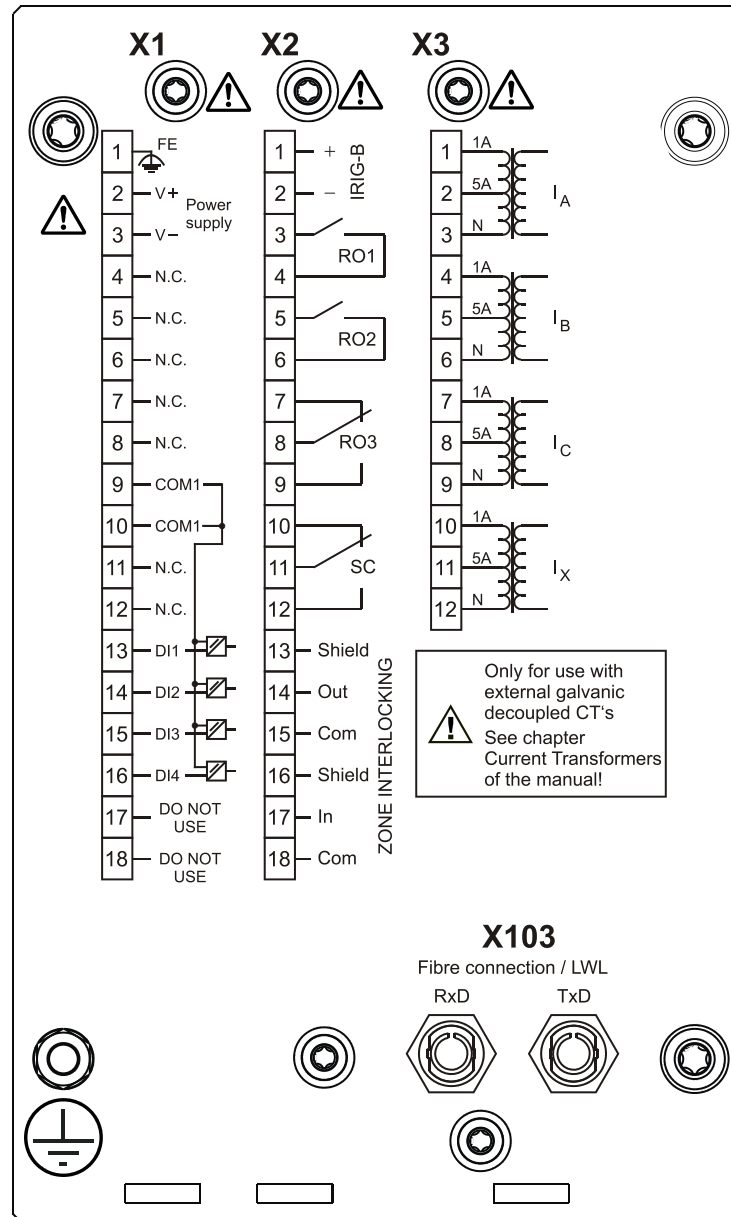

EDR-3000-2C0DB

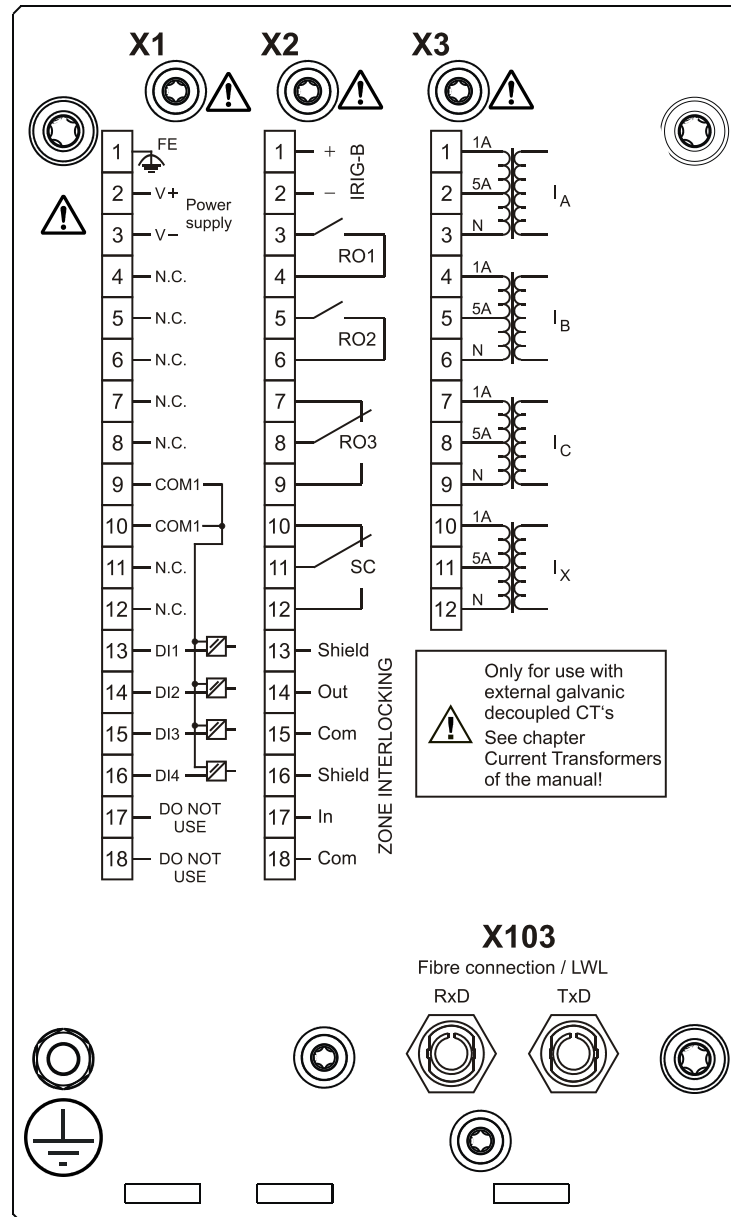

EDR-3000-2C0EA

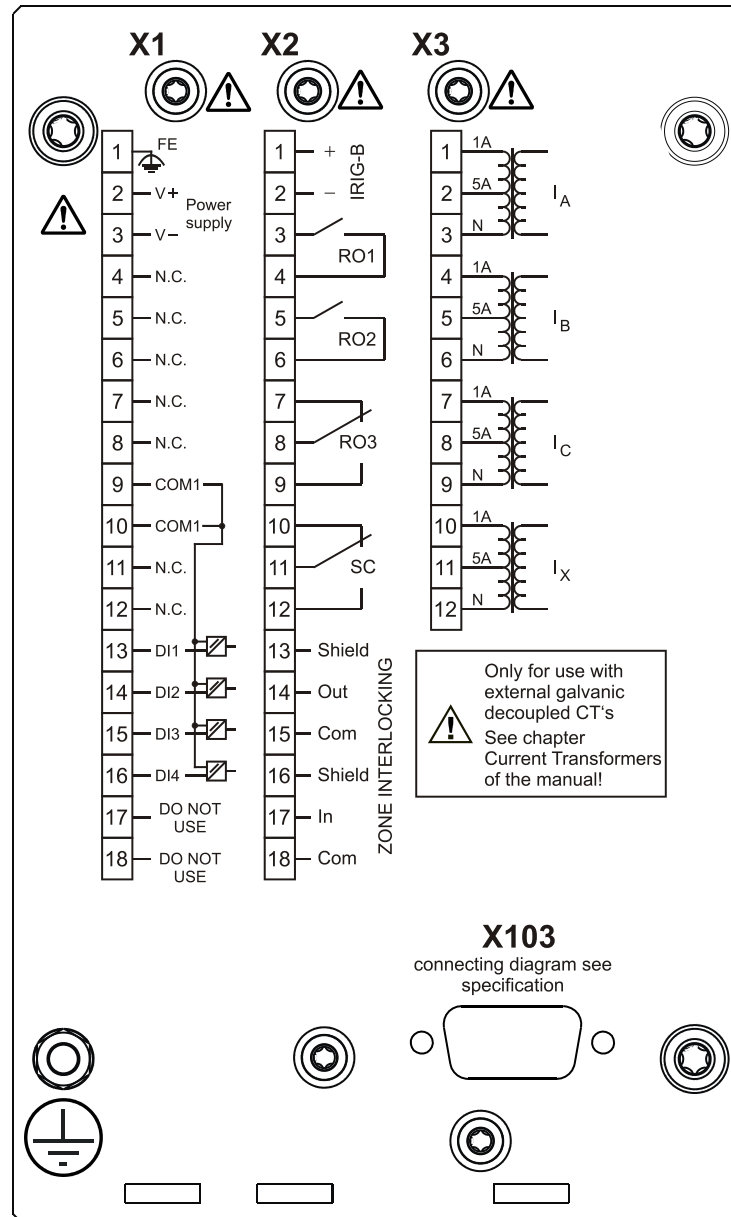

EDR-3000-2C0EB

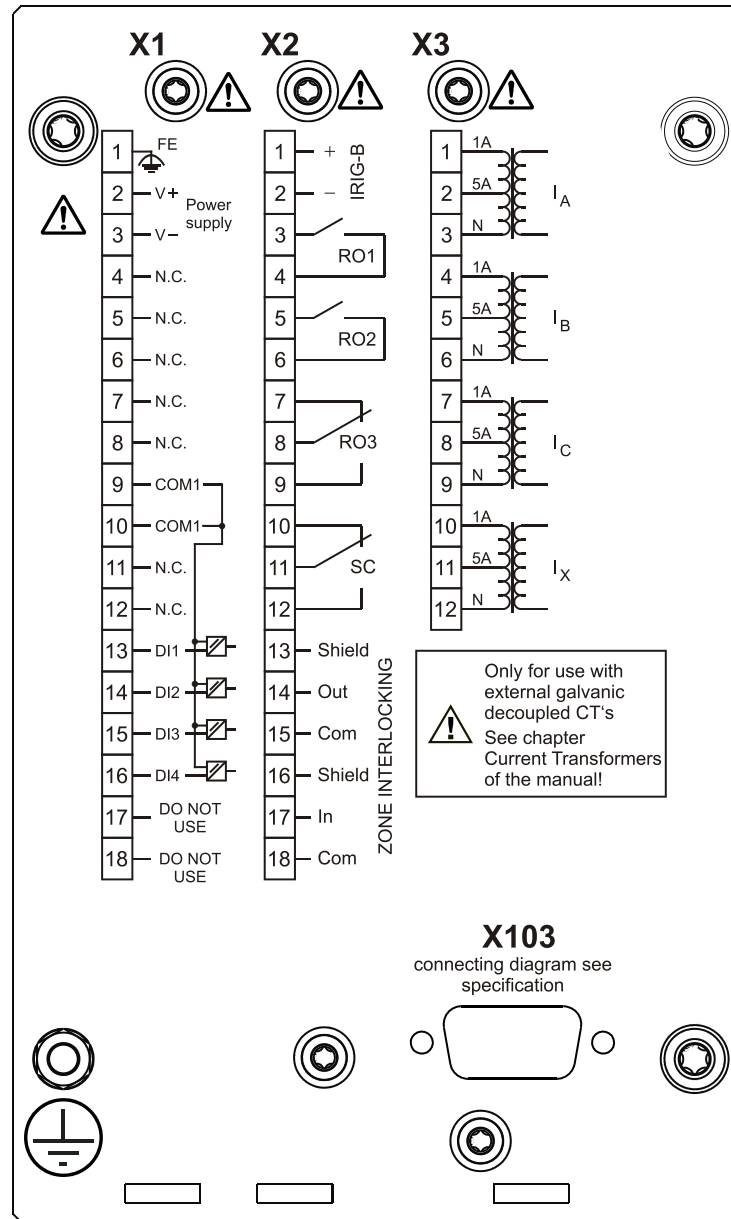

EDR-3000-2C0FA

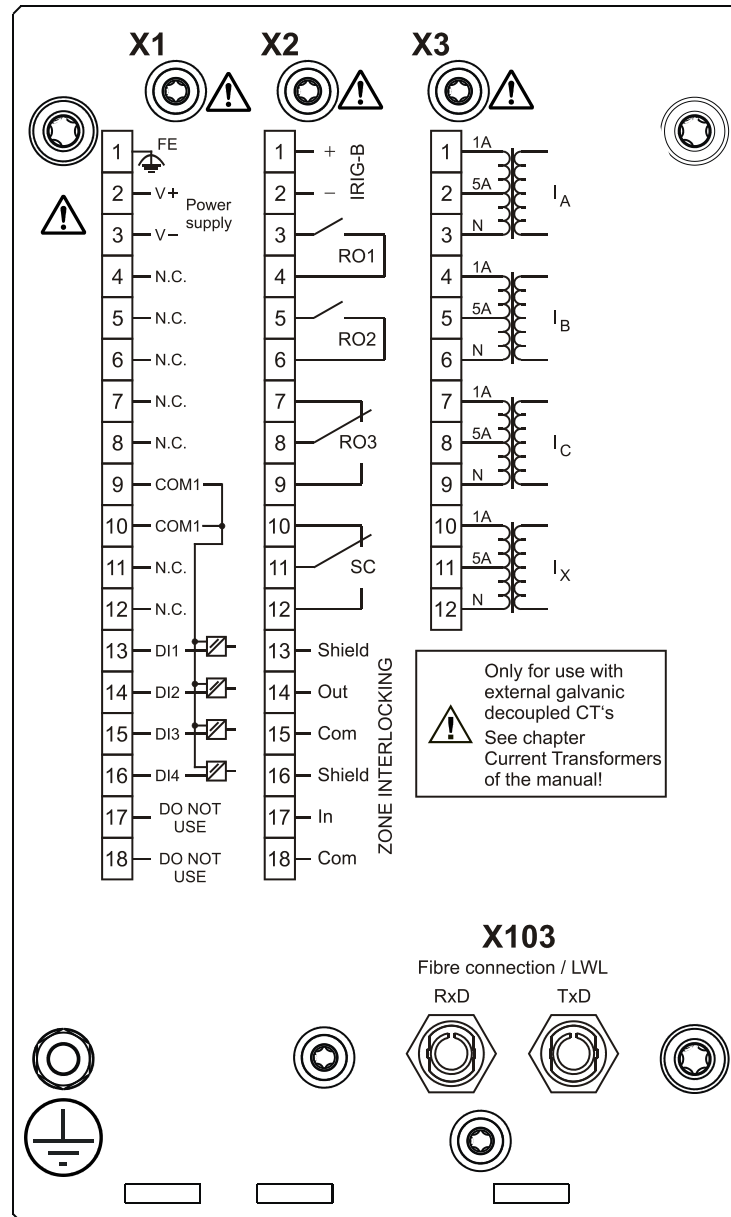

EDR-3000-2C0FB

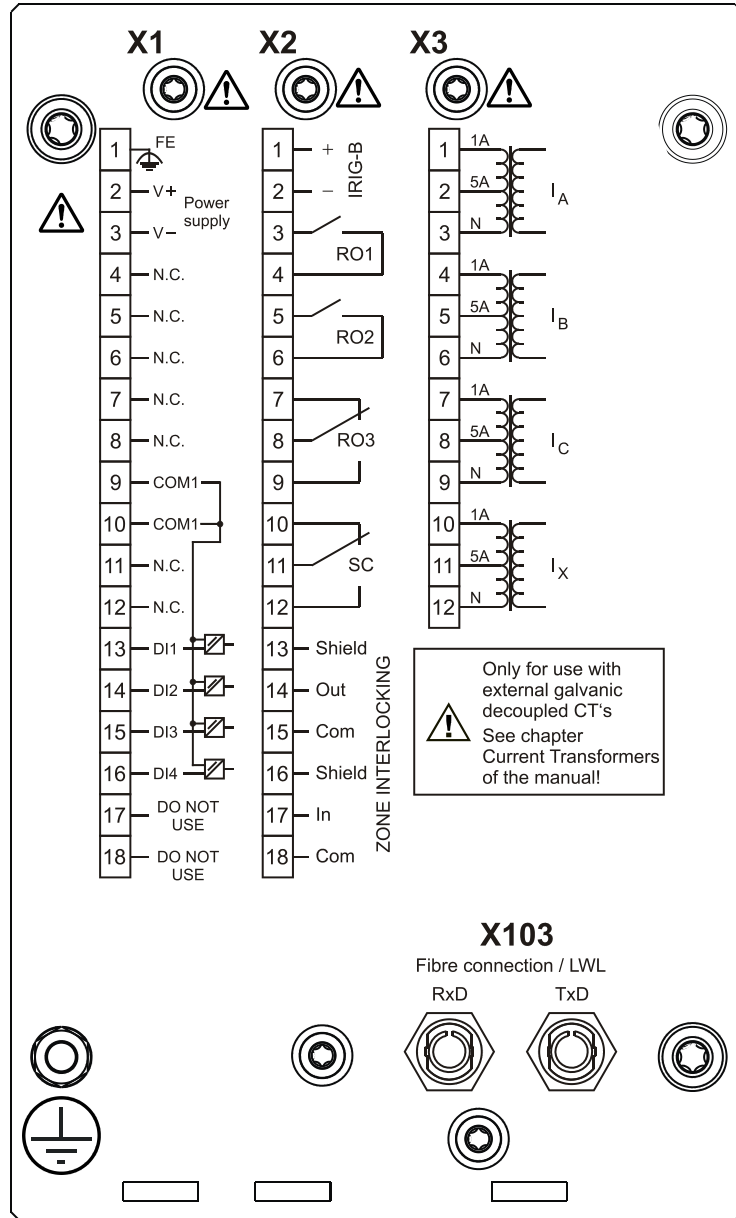

EDR-3000-2C0GA

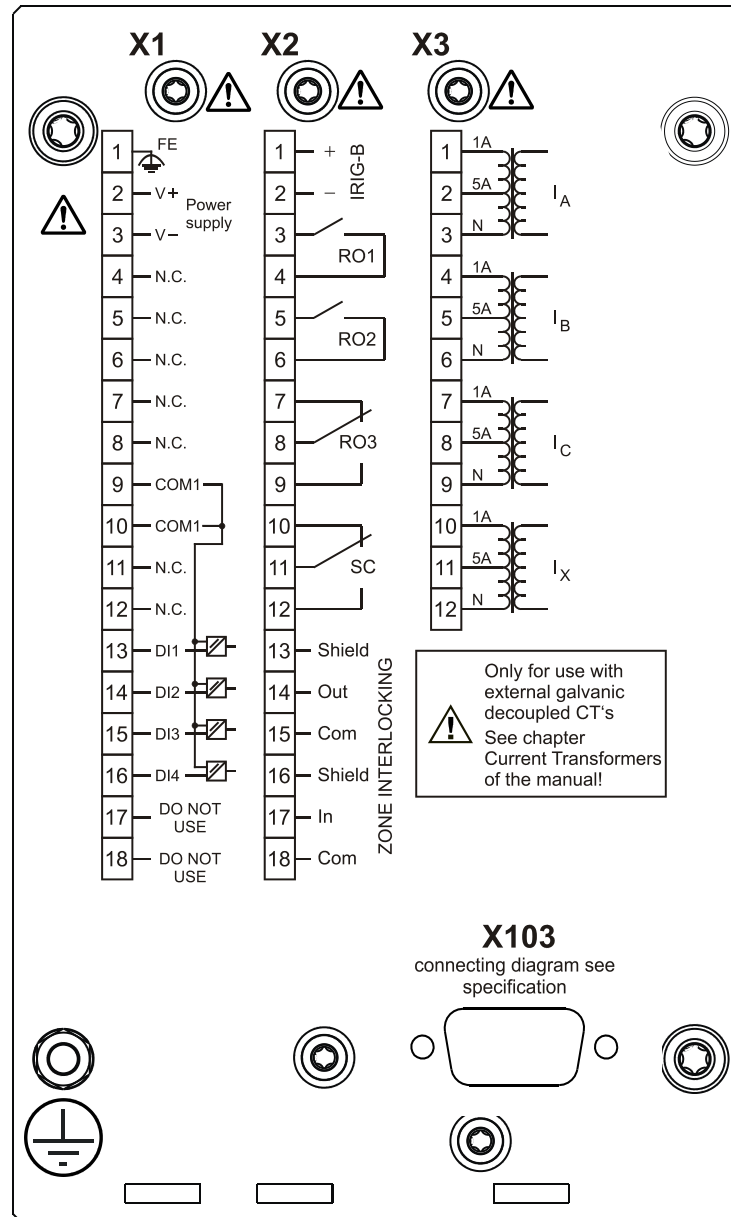

EDR-3000-2C0GB

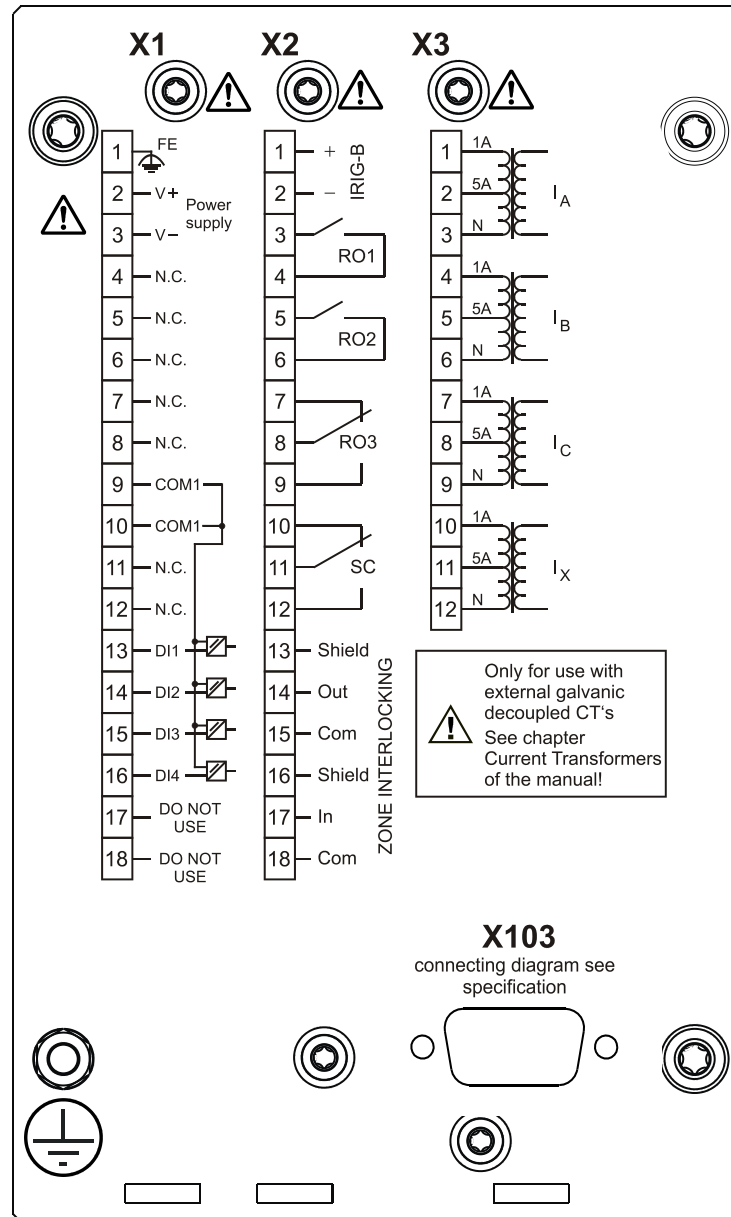

EDR-3000-2C0HA

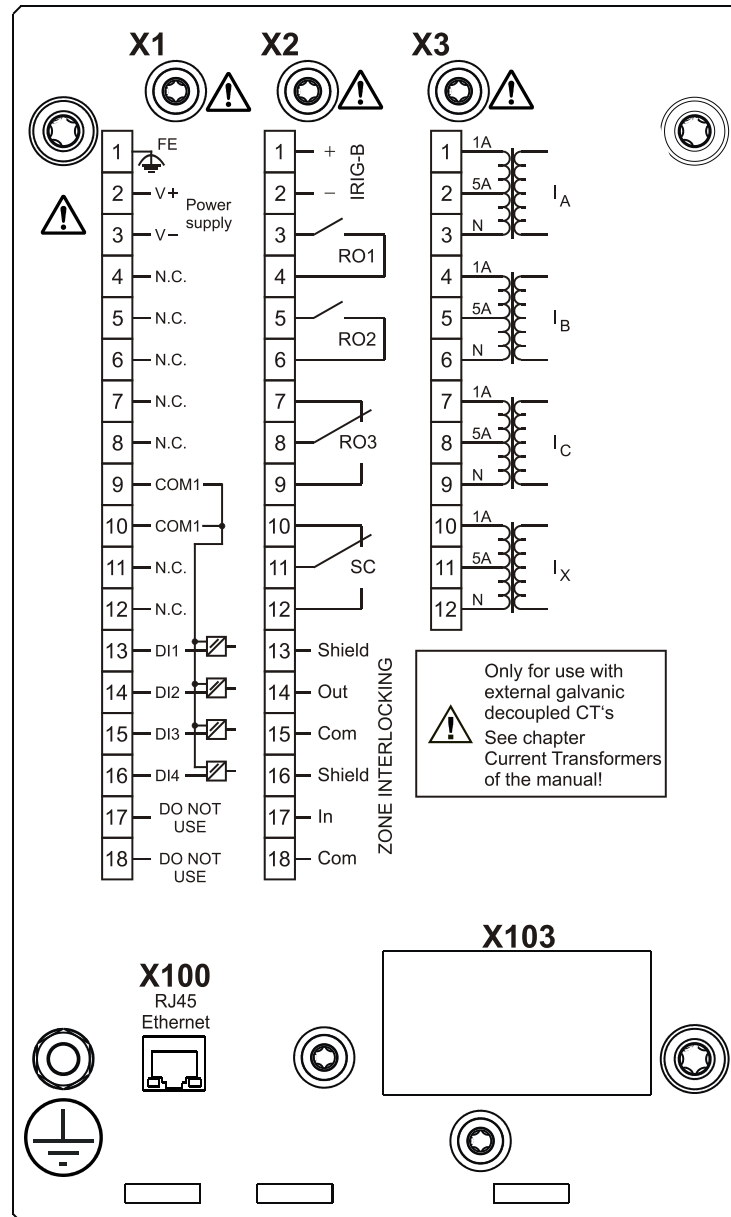

EDR-3000-2C0HB

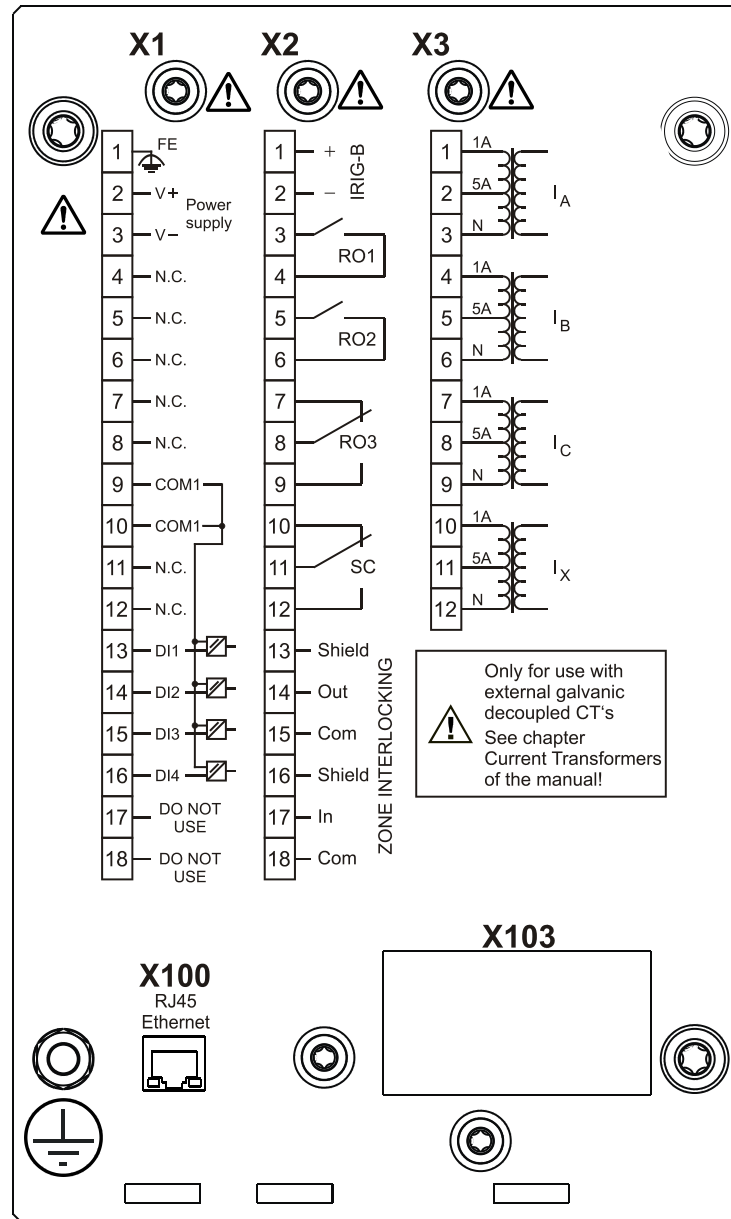

EDR-3000-2C01A

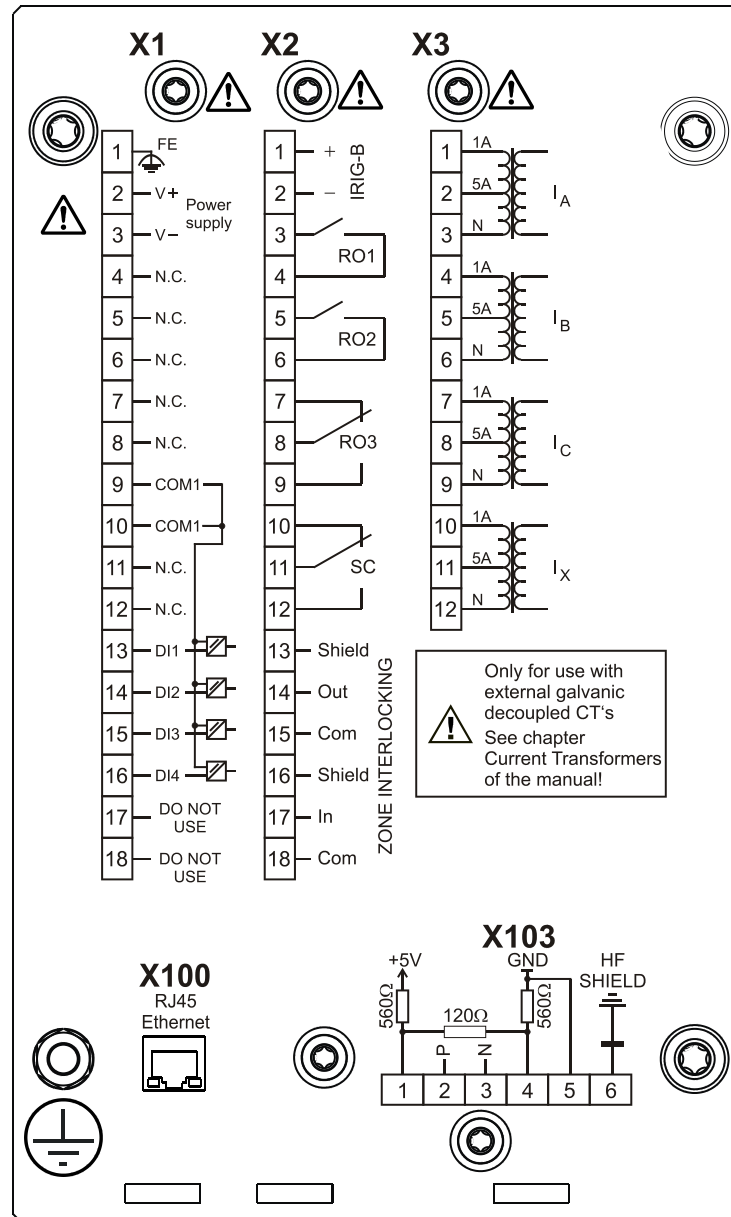

EDR-3000-2C0IB

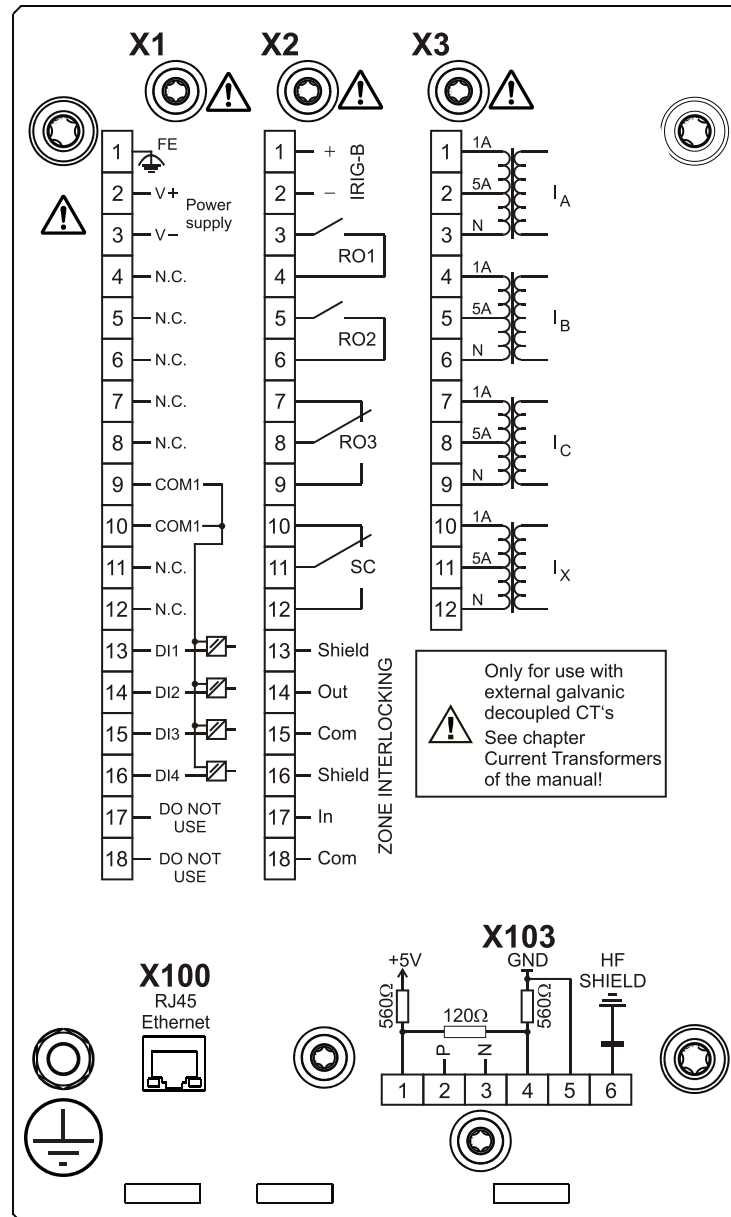

EDR-3000-2C0KA

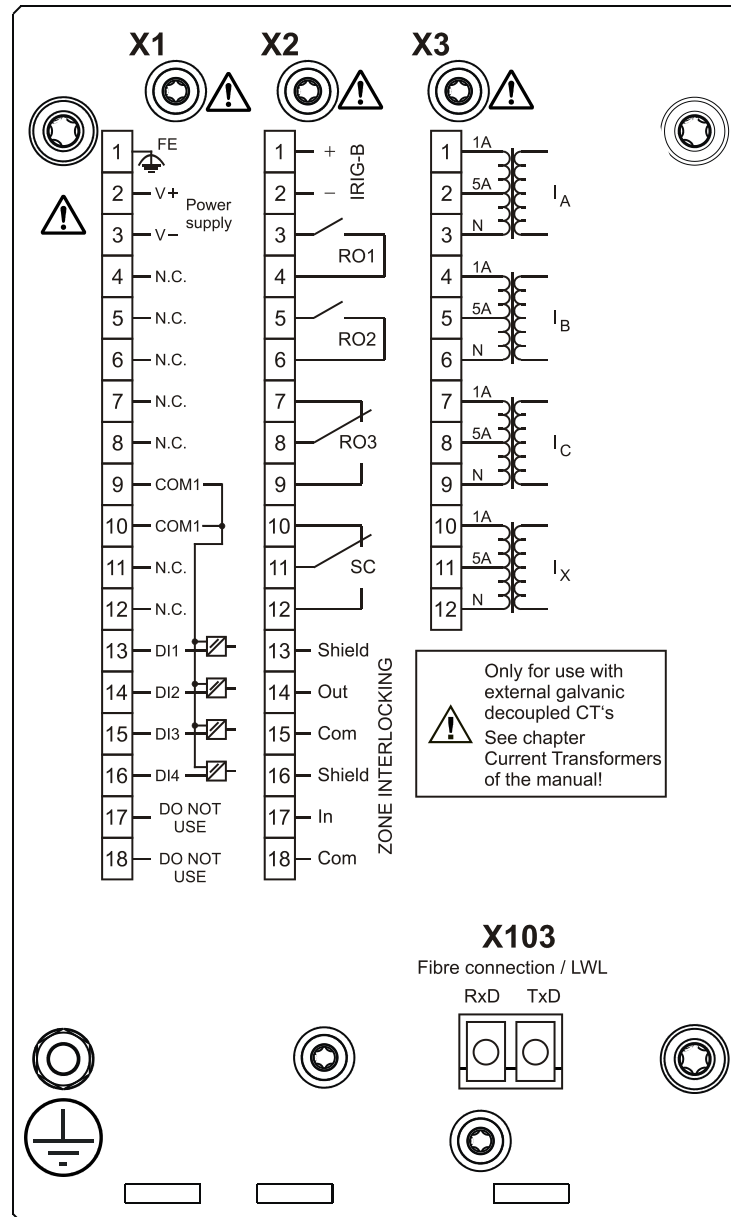

EDR-3000-2C0KB

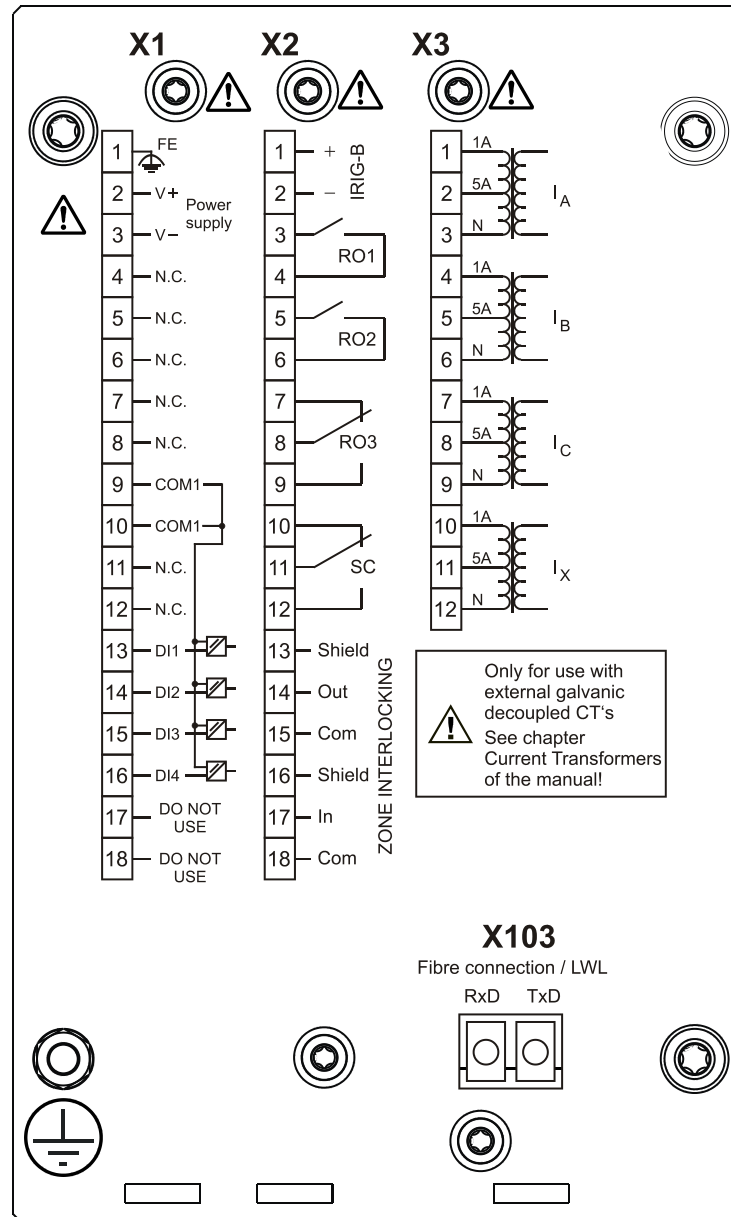

EDR-3000-2C0LA

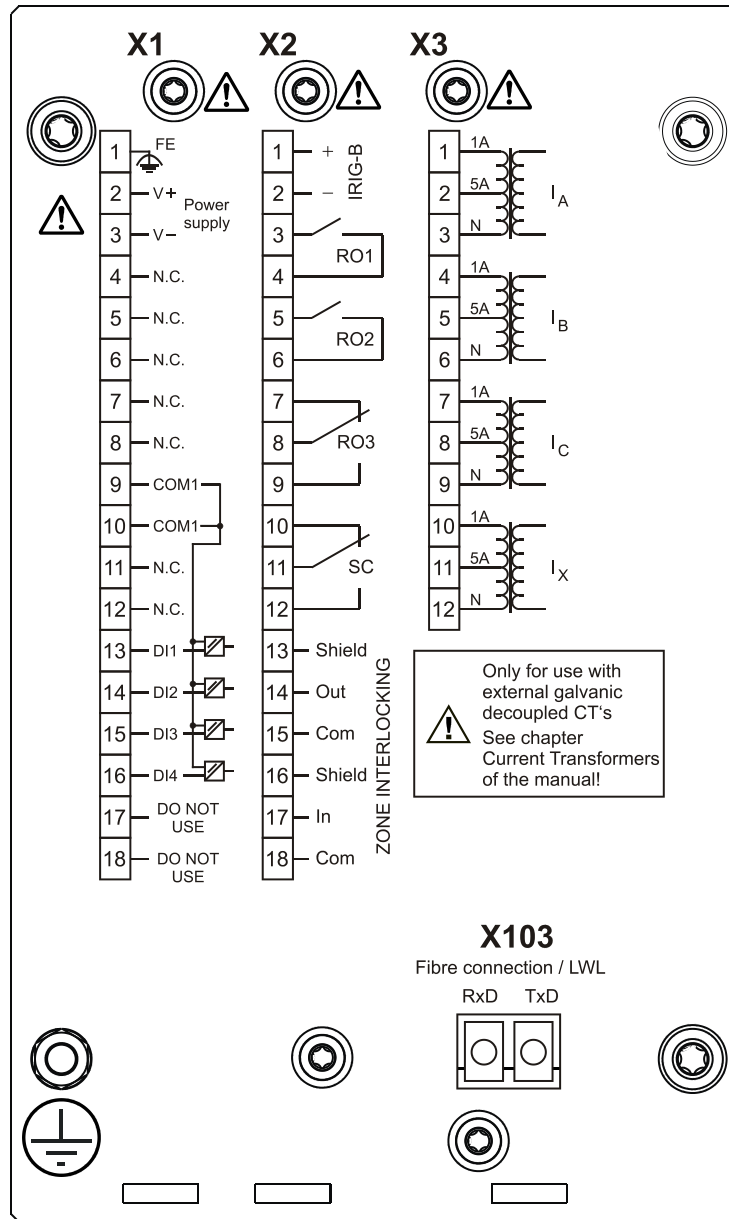

EDR-3000-2C0LB

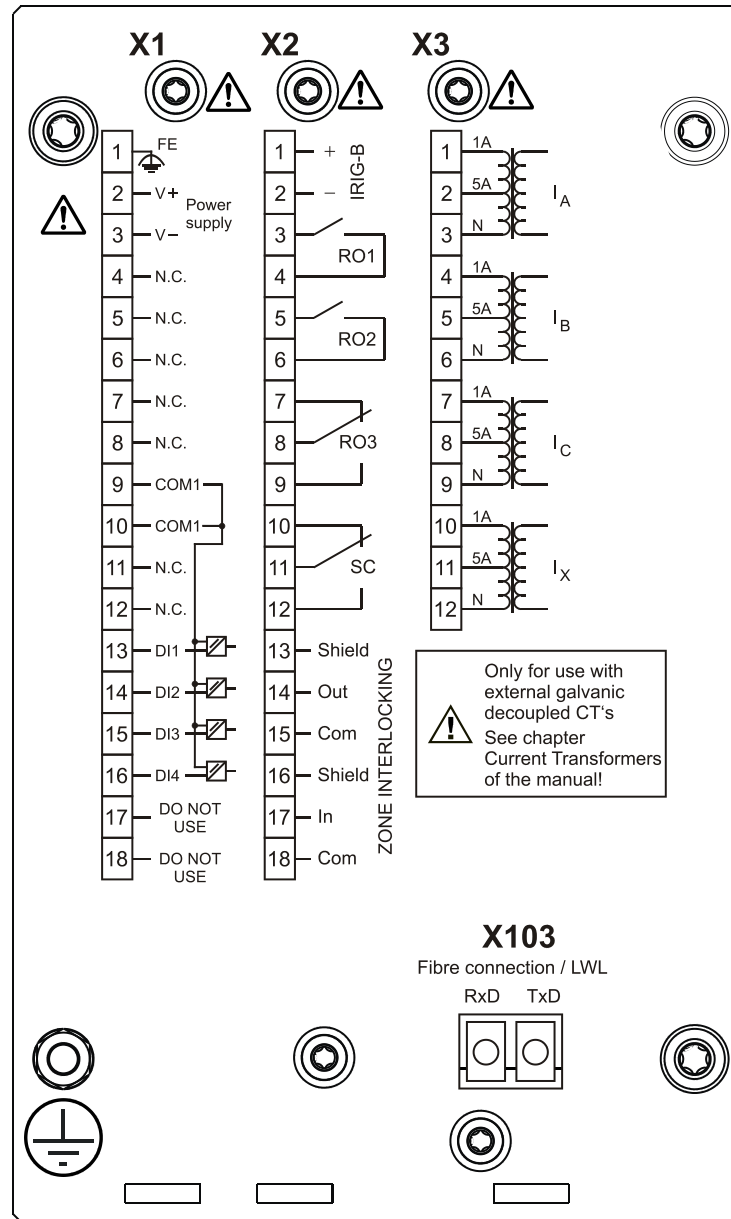

EDR-3000-2C1AA

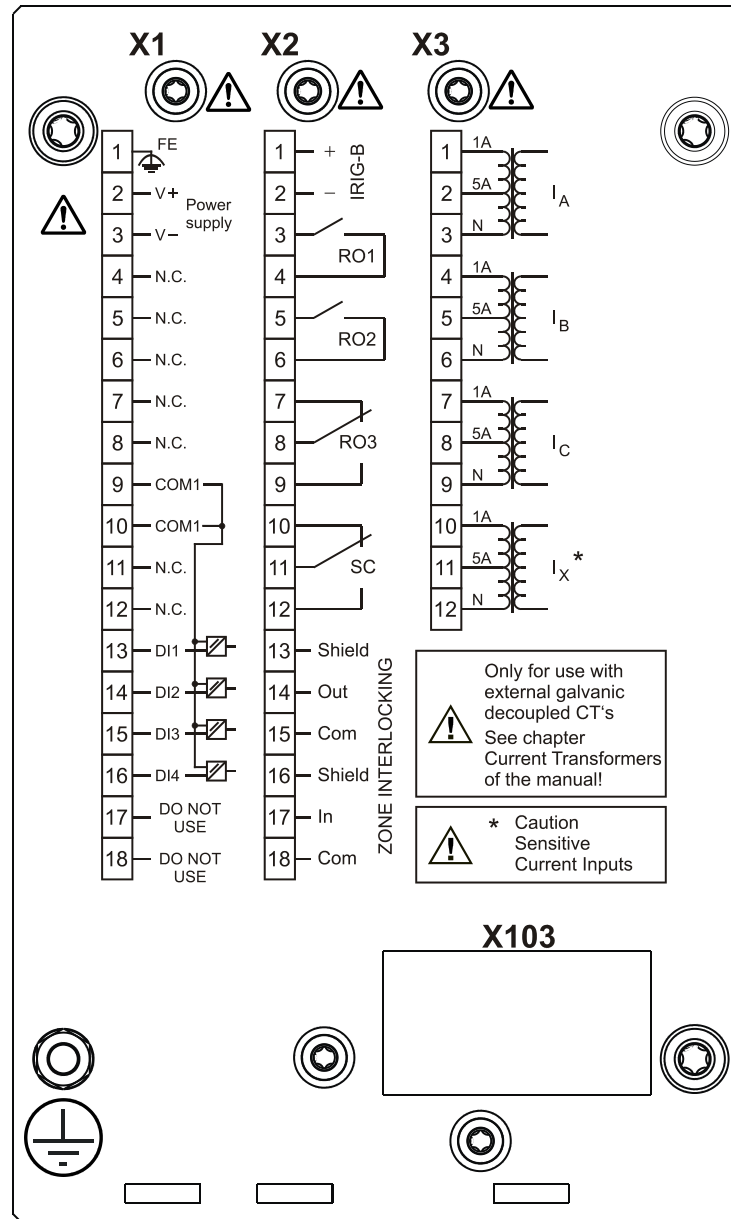

EDR-3000-2C1AB

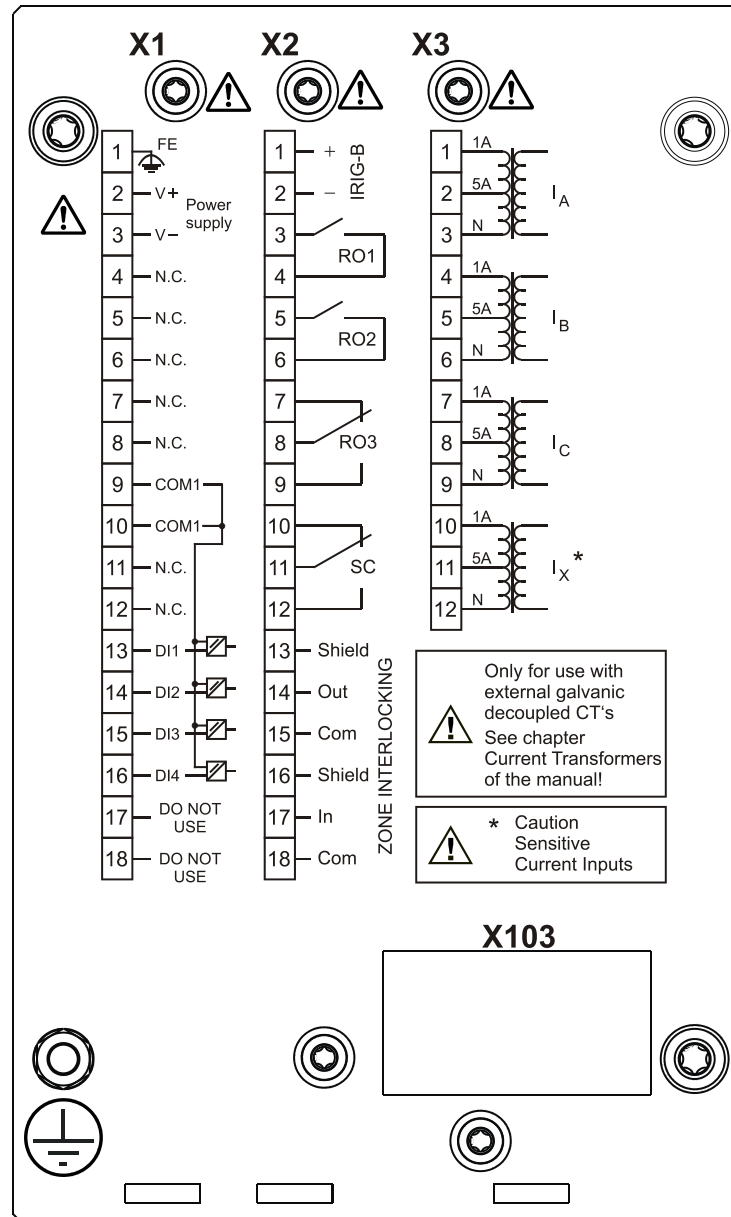

EDR-3000-2C1BA

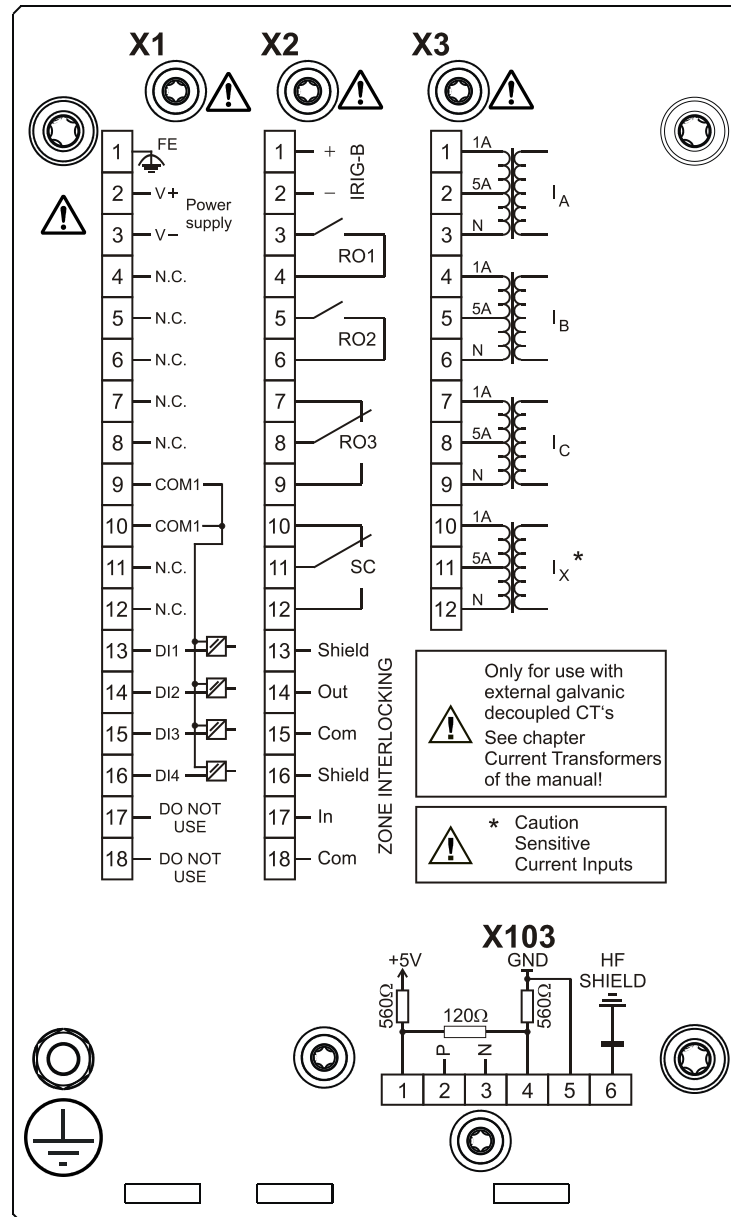

EDR-3000-2C1BB

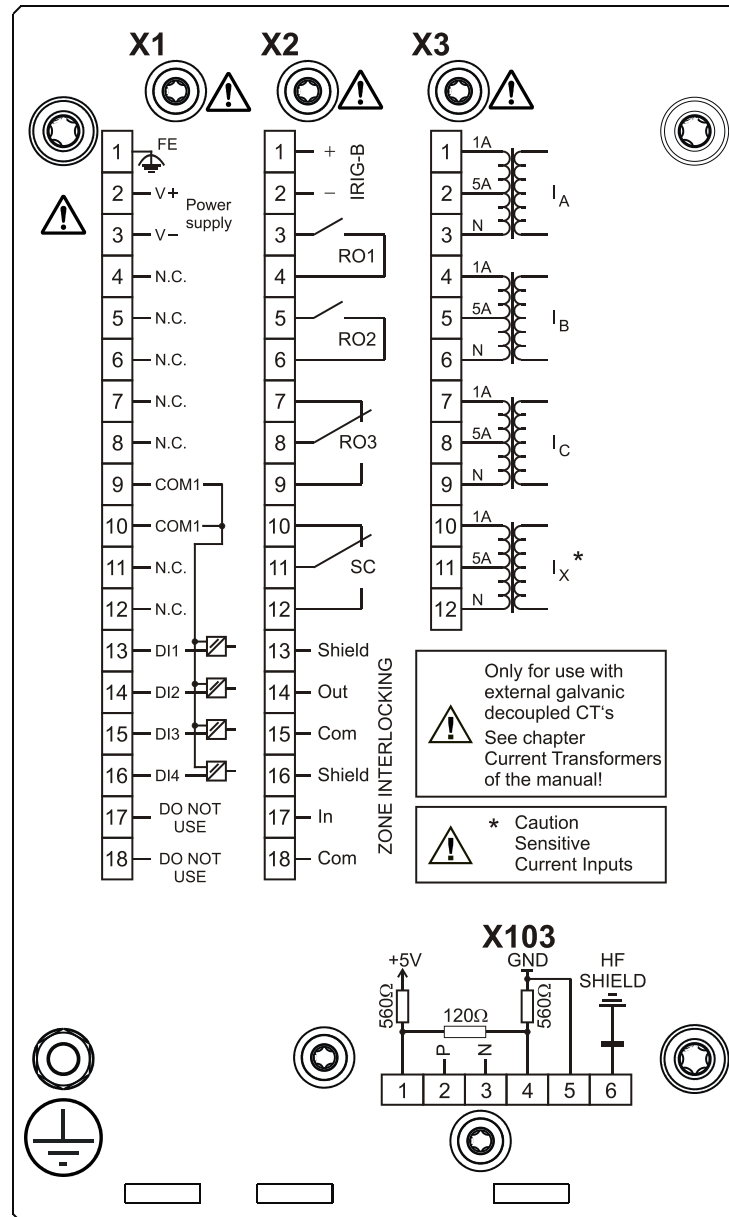

EDR-3000-2C1CA

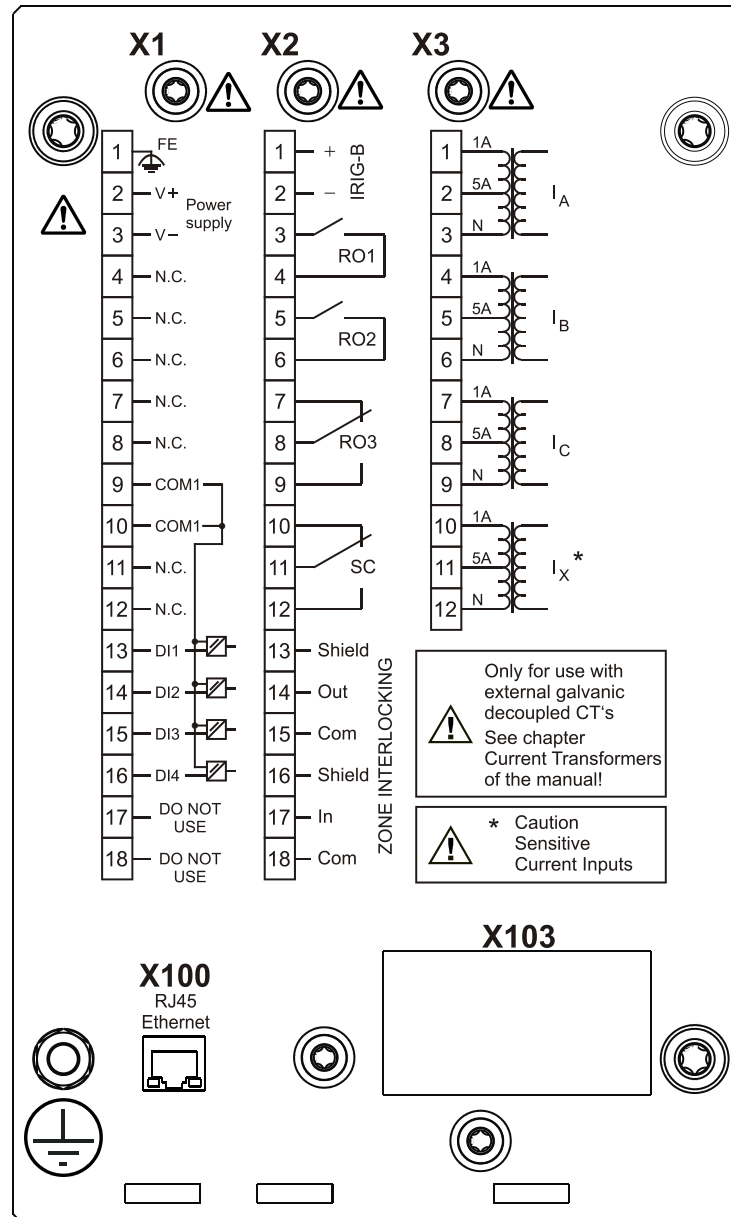

EDR-3000-2C1CB

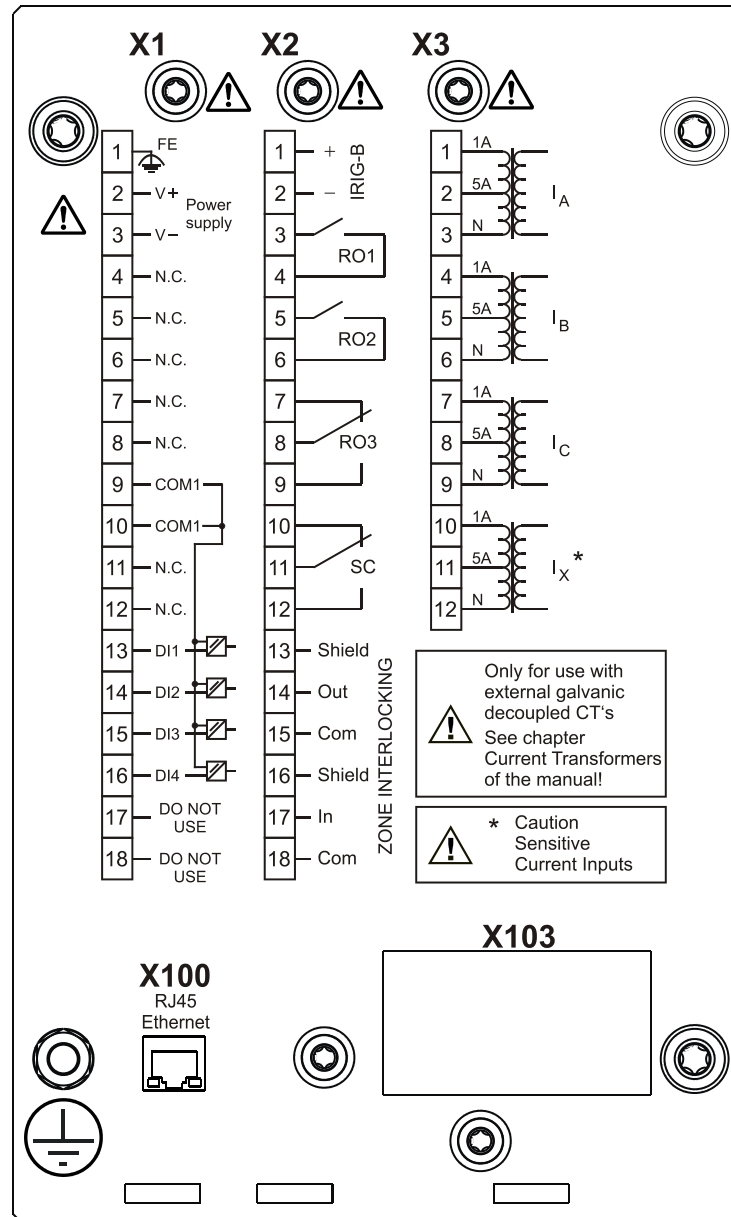

EDR-3000-2C1DA

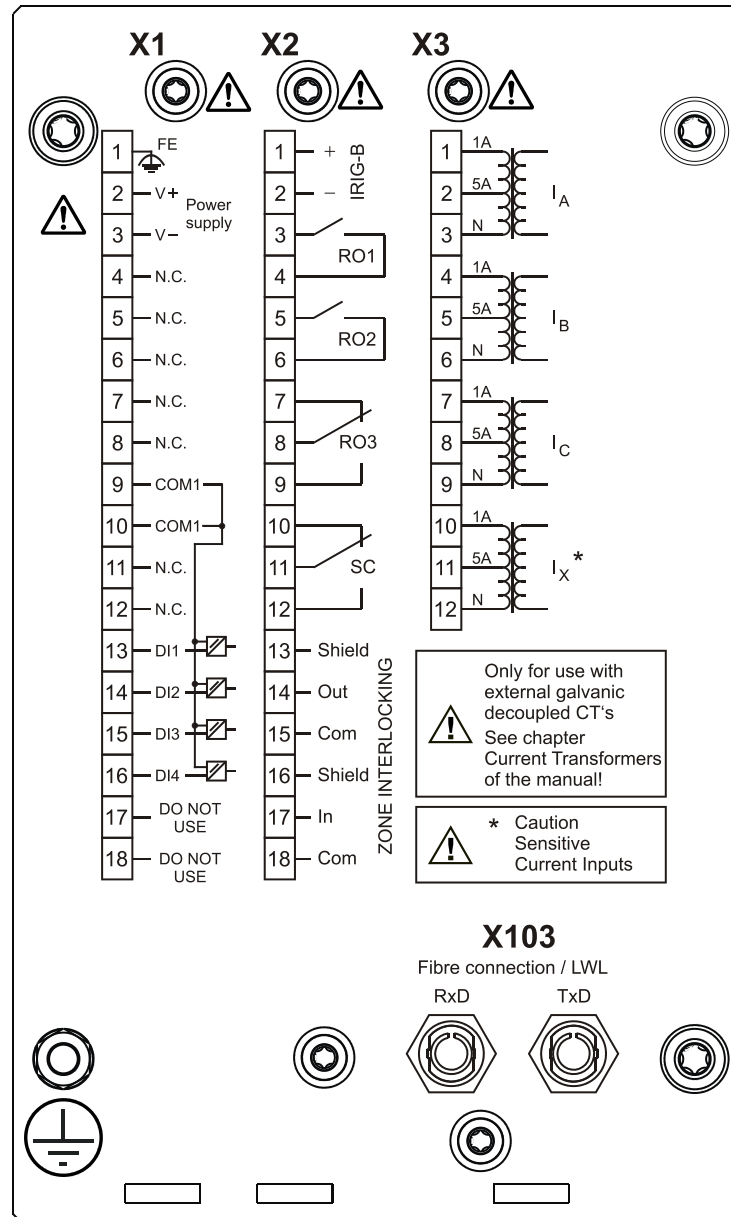

EDR-3000-2C1DB

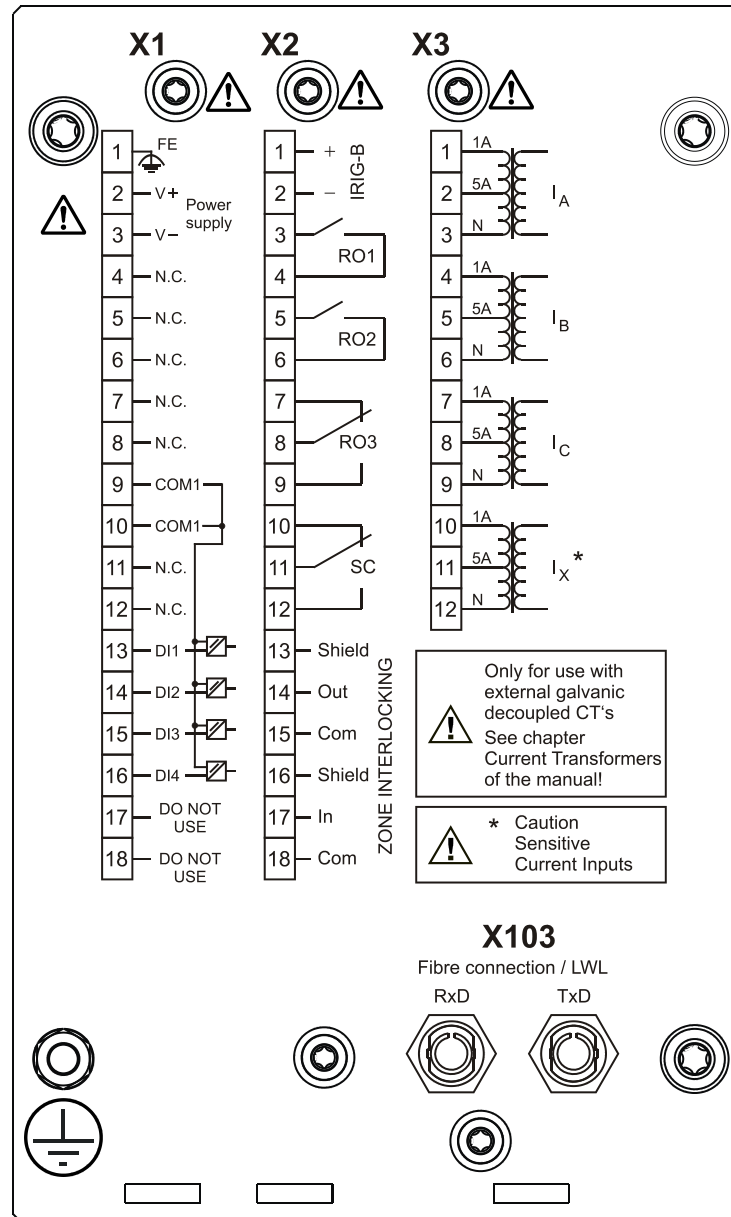

EDR-3000-2C1EA

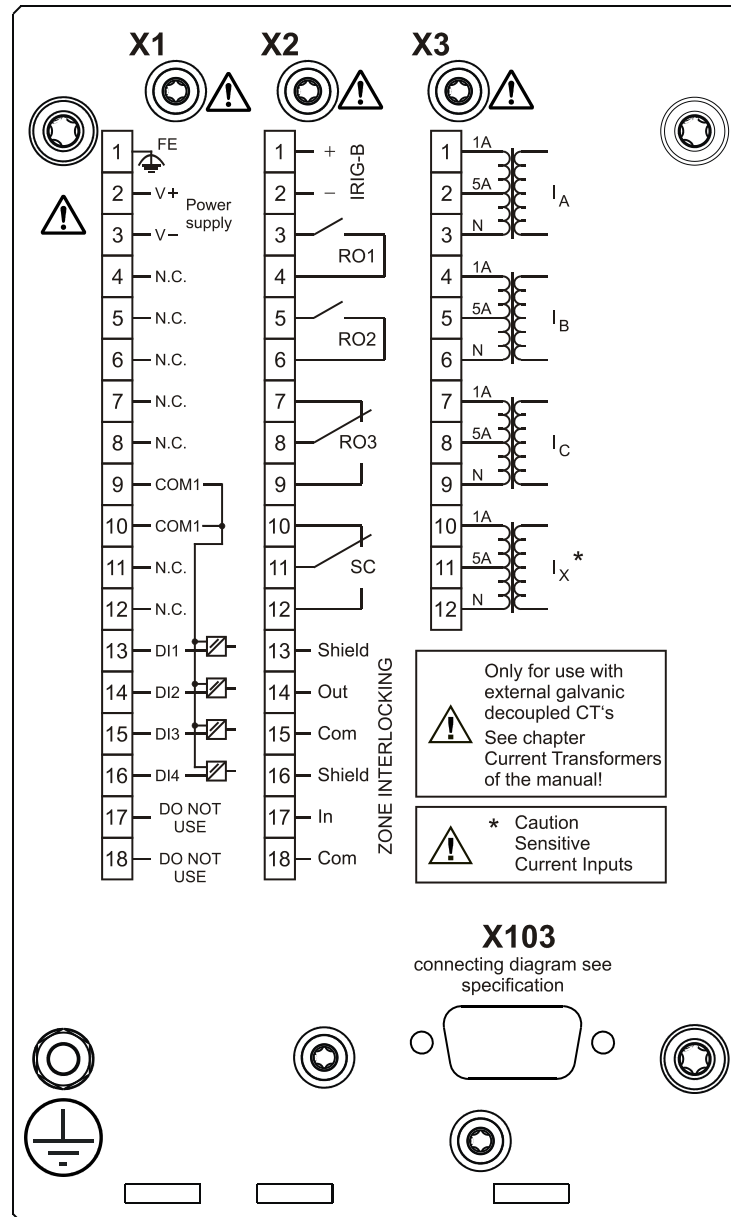

EDR-3000-2C1EB

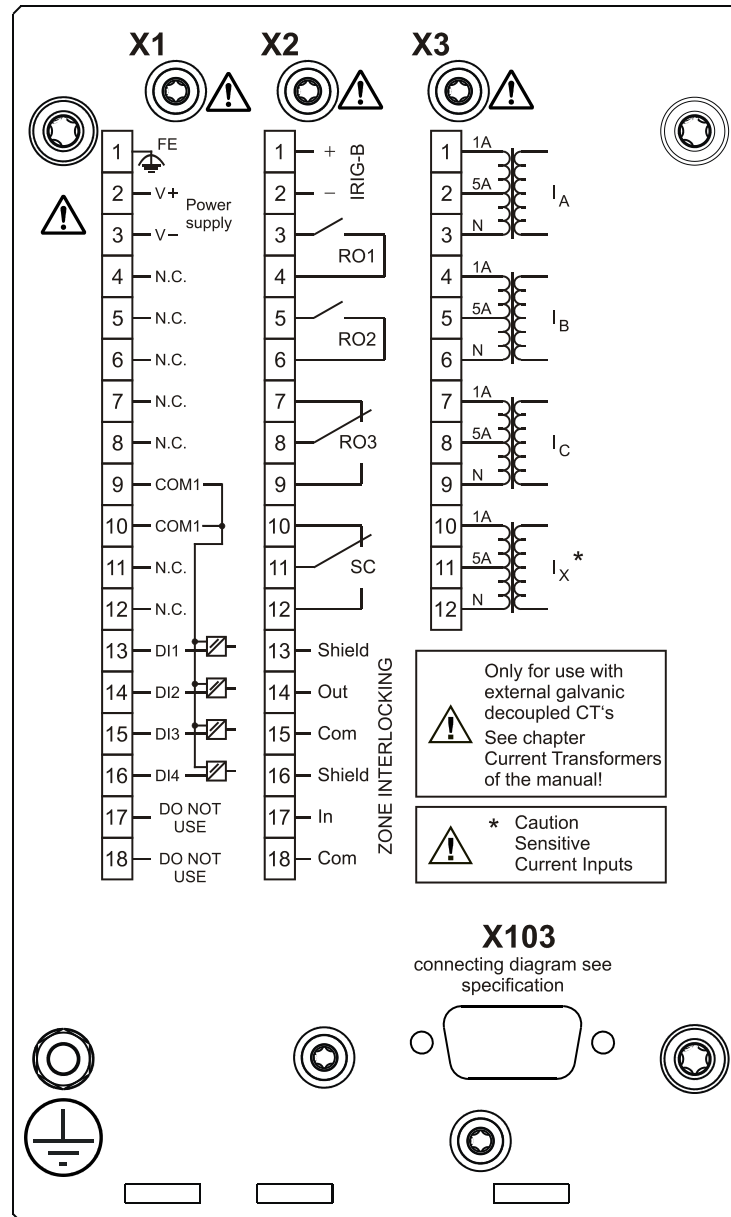

EDR-3000-2C1FA

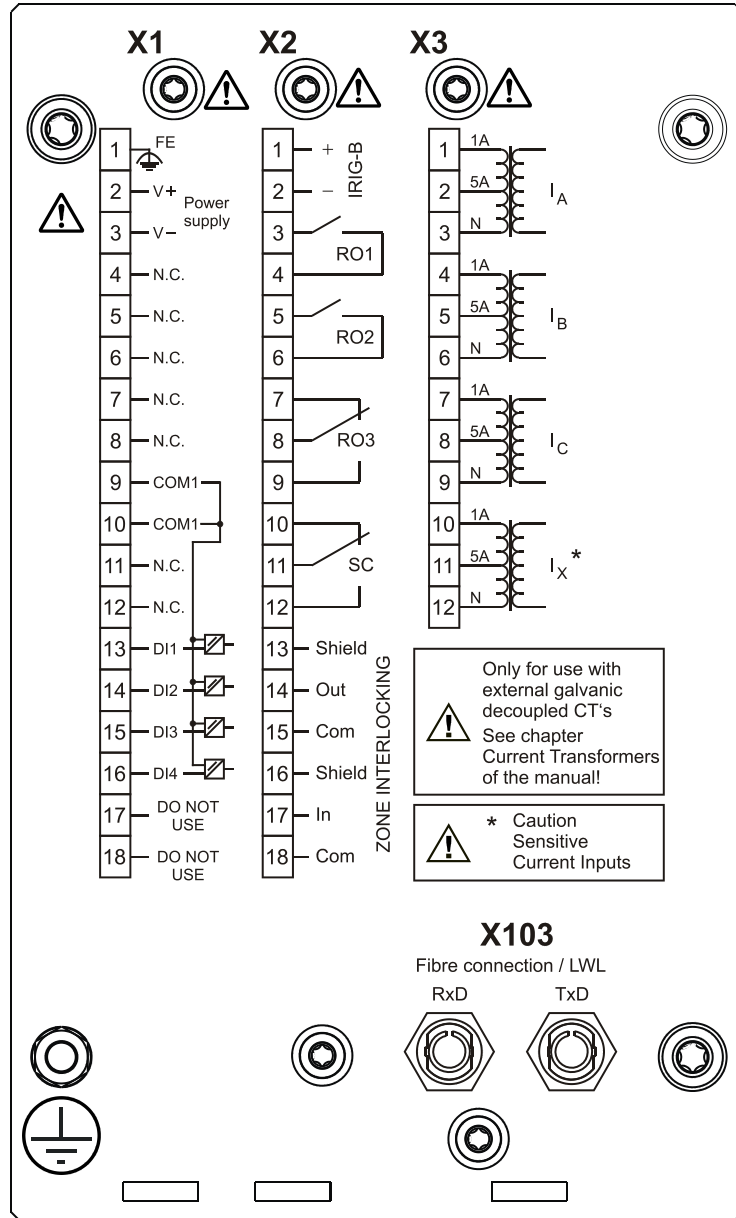

EDR-3000-2C1FB

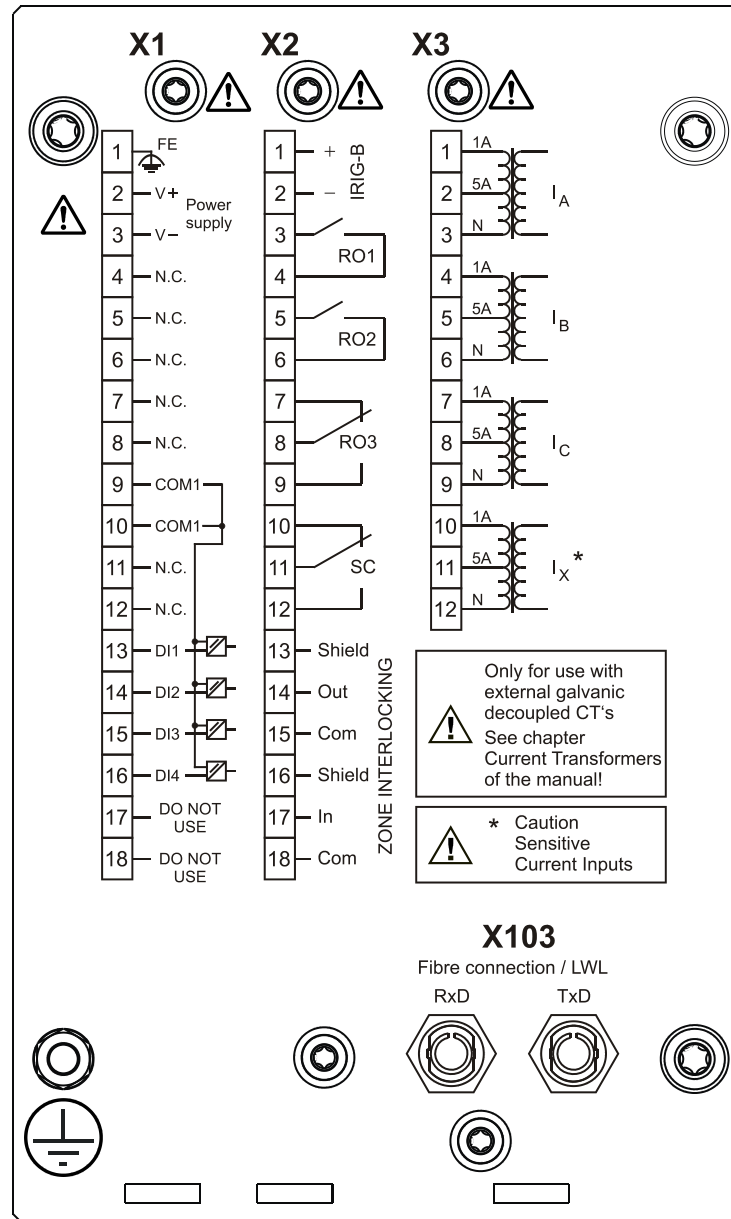

EDR-3000-2C1GA

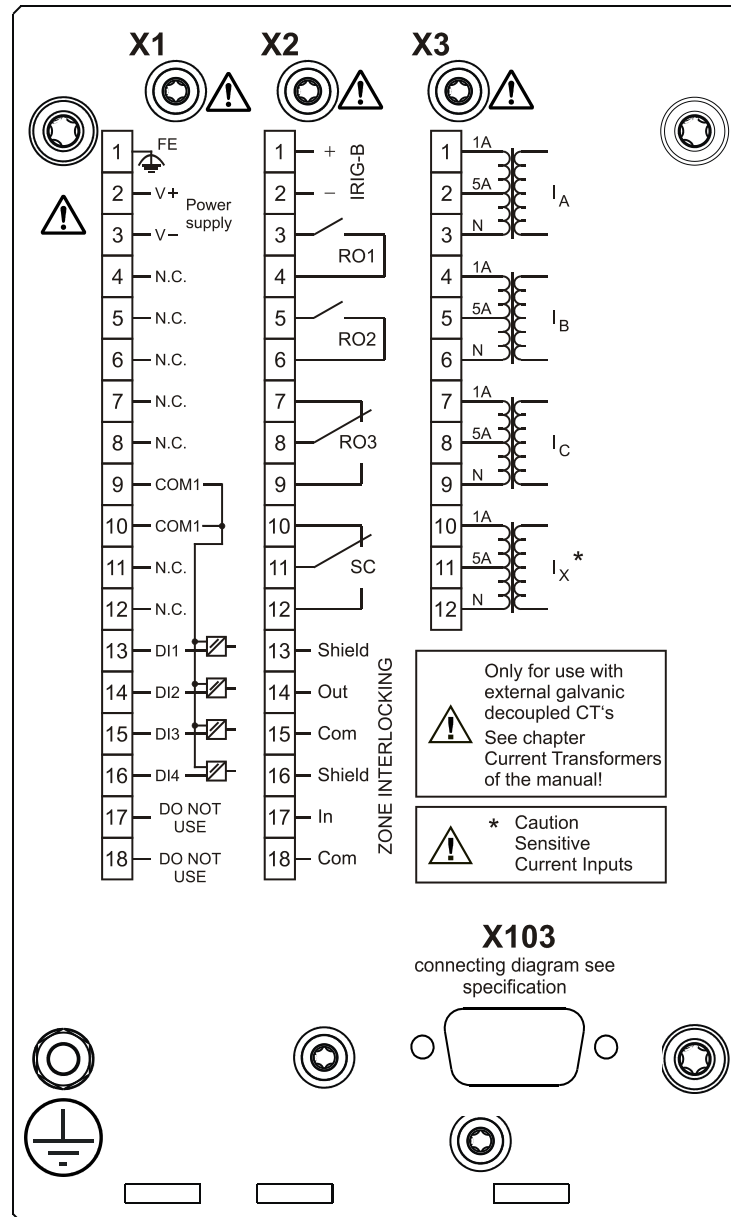

EDR-3000-2C1GB

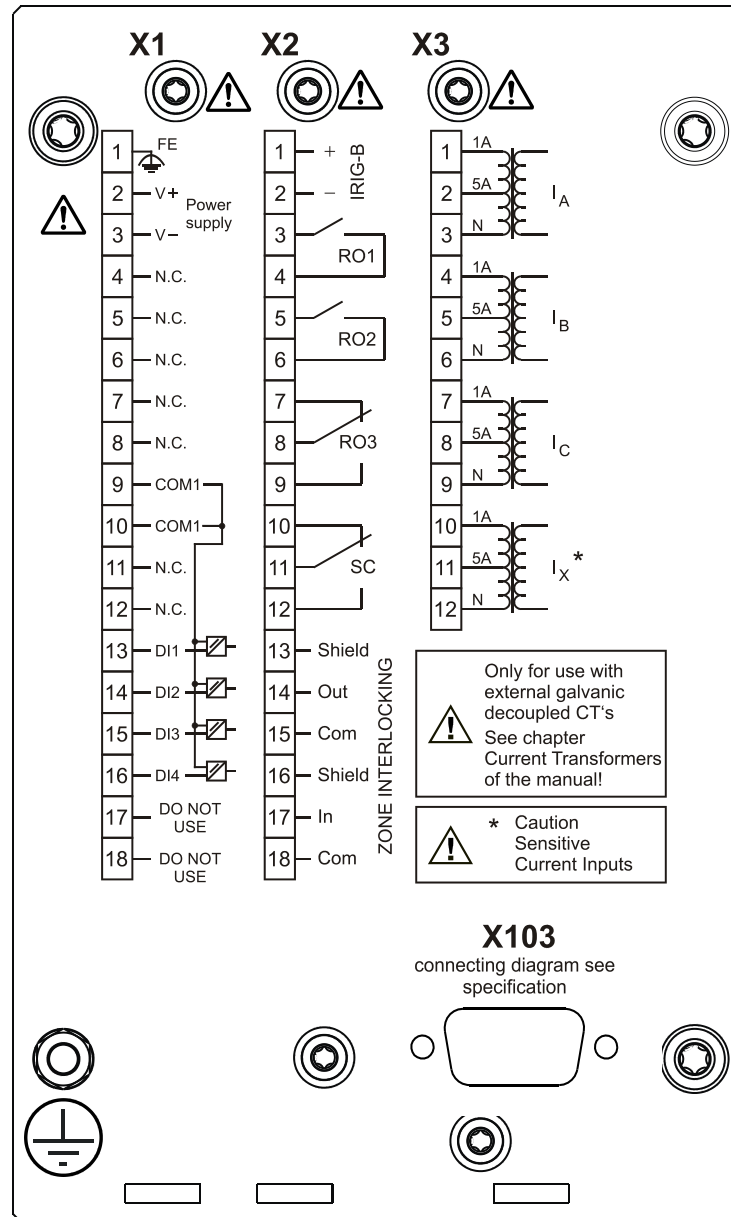

EDR-3000-2C1HA

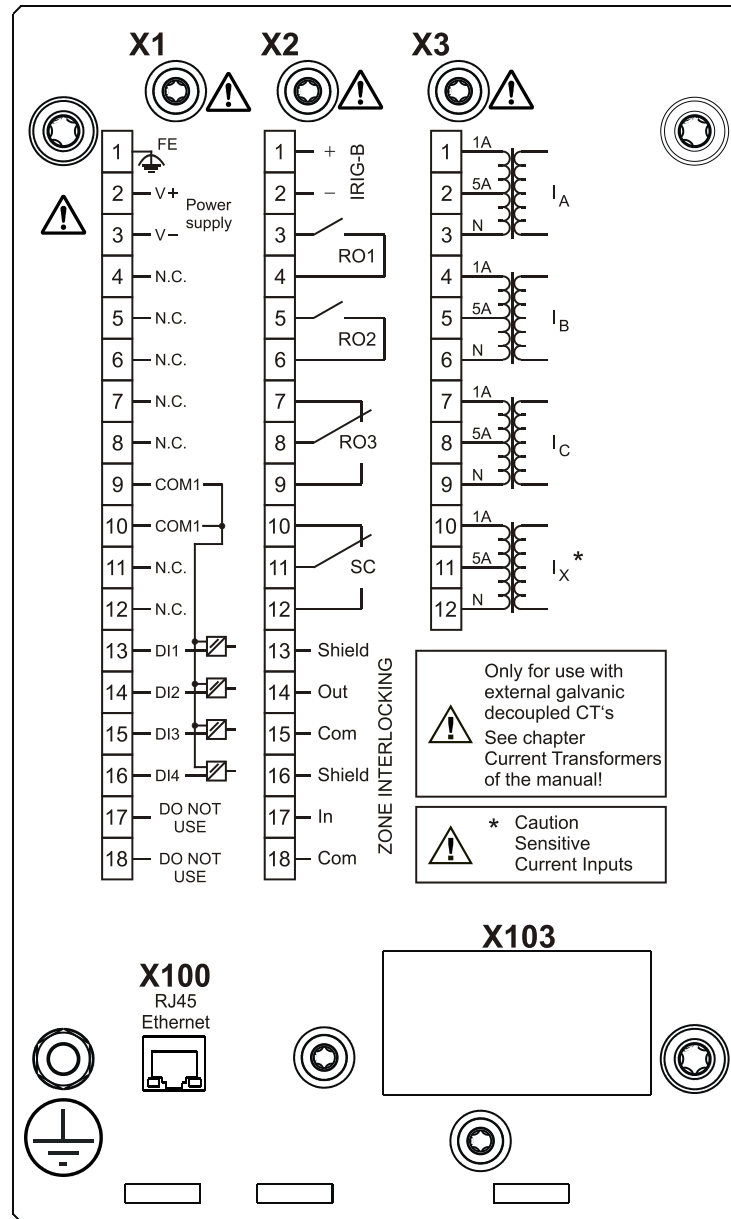

EDR-3000-2C1HB

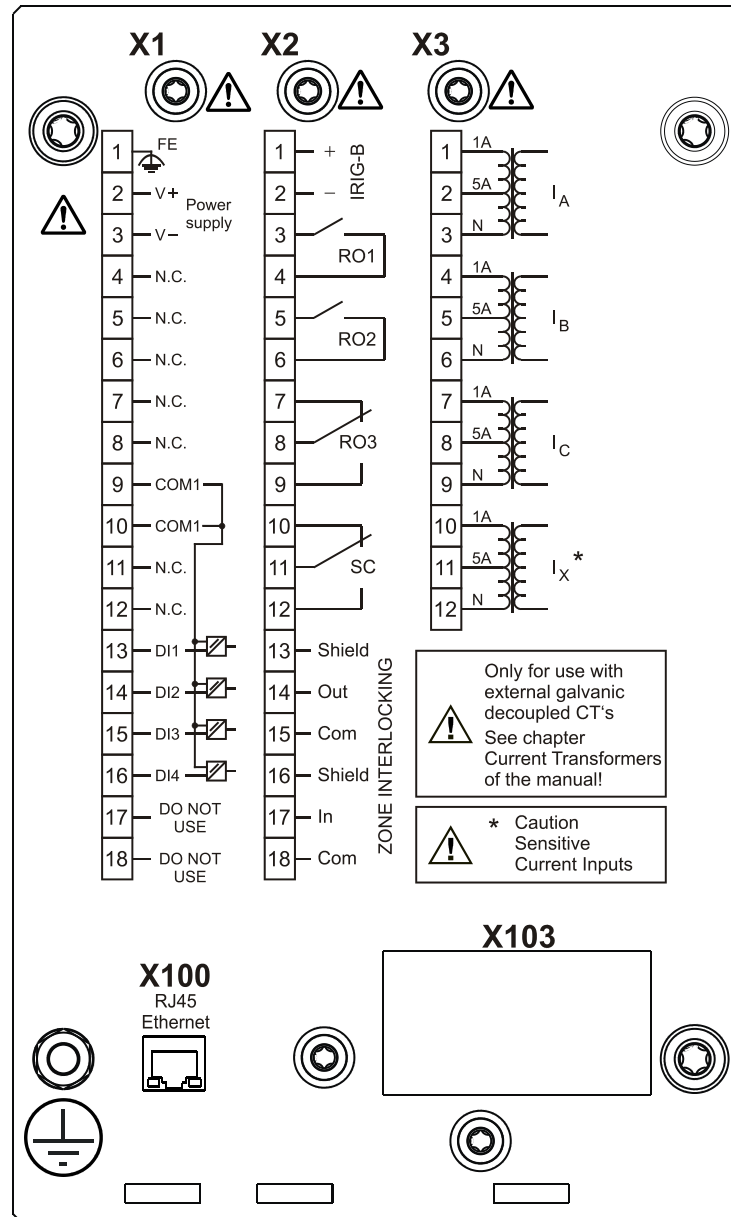

EDR-3000-2C11A

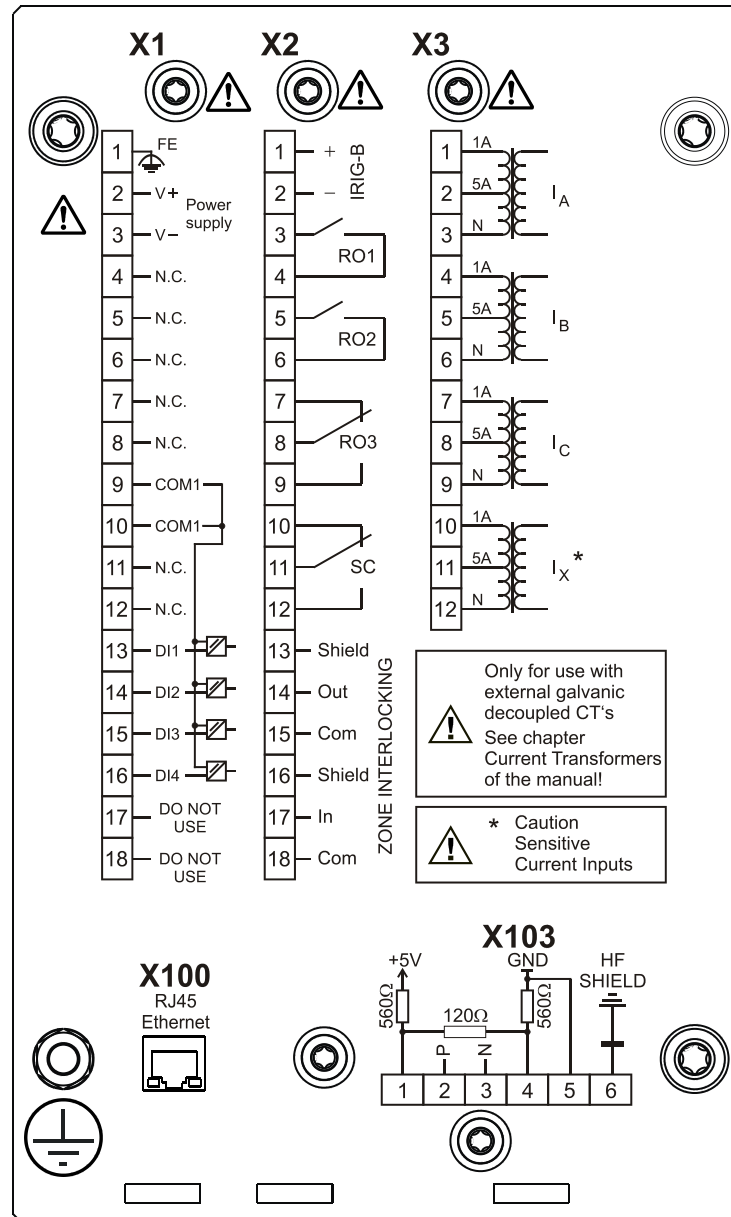

EDR-3000-2C1IB

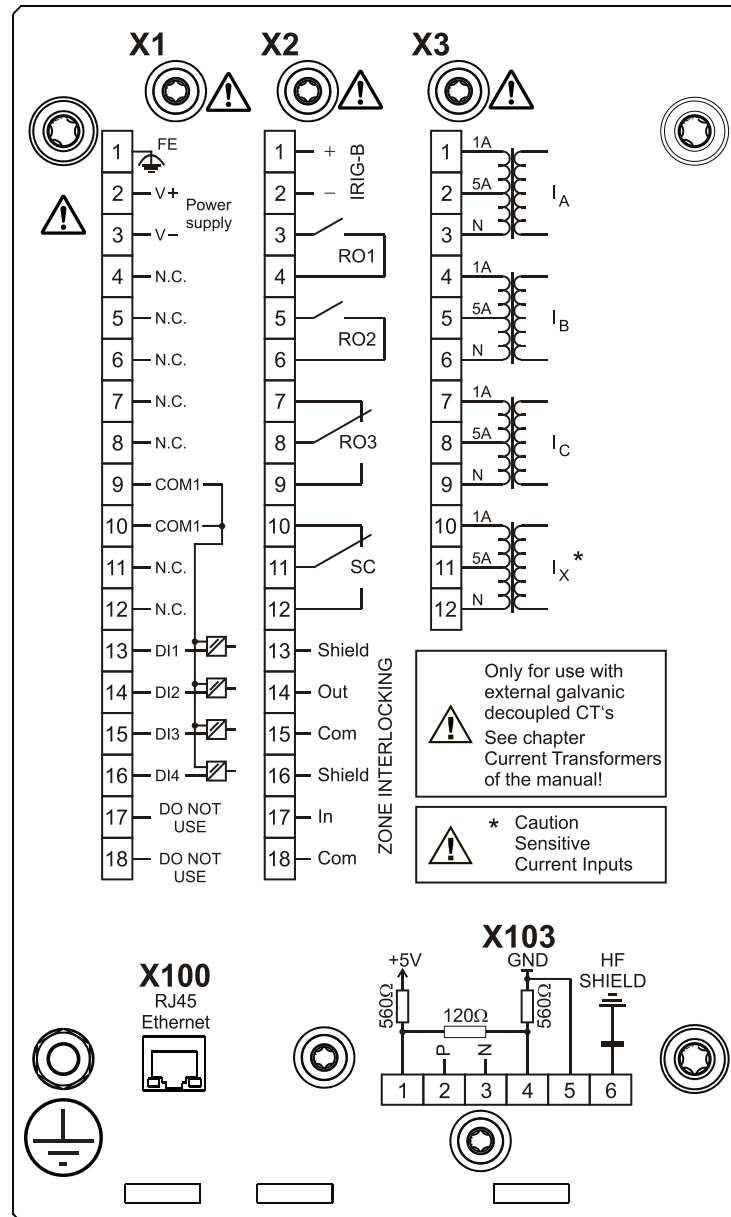

EDR-3000-2C1KA

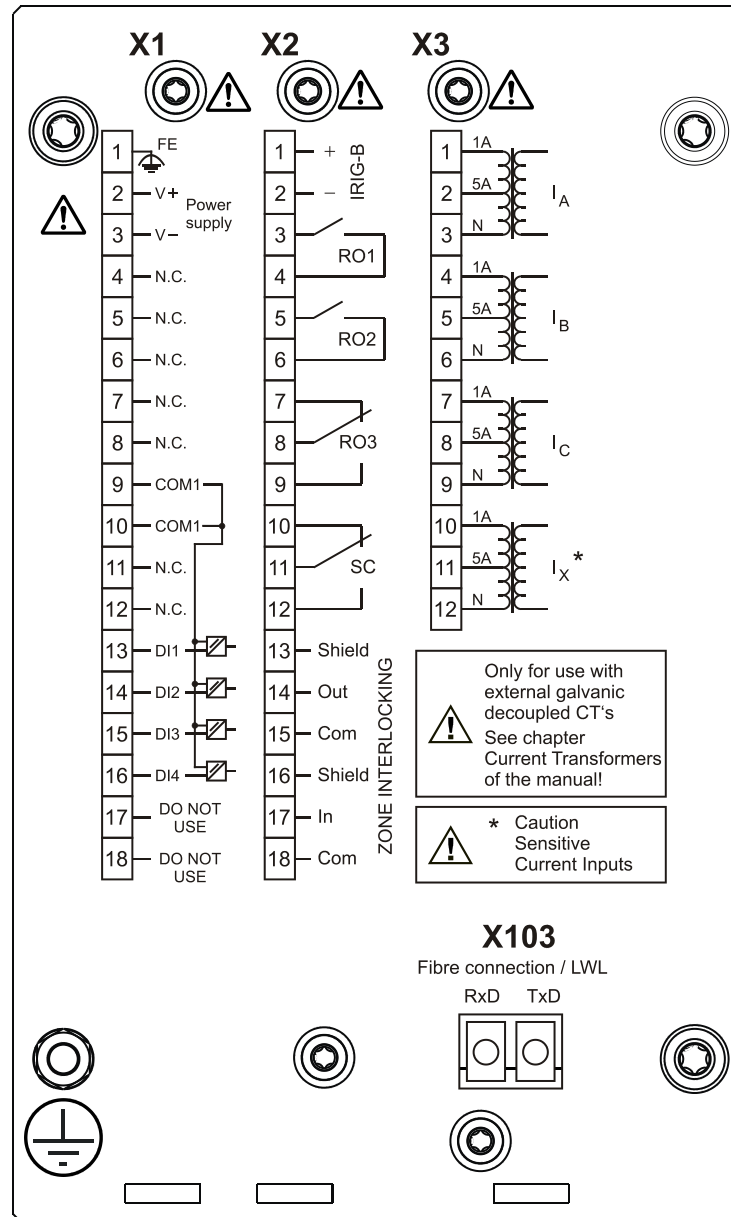

EDR-3000-2C1KB

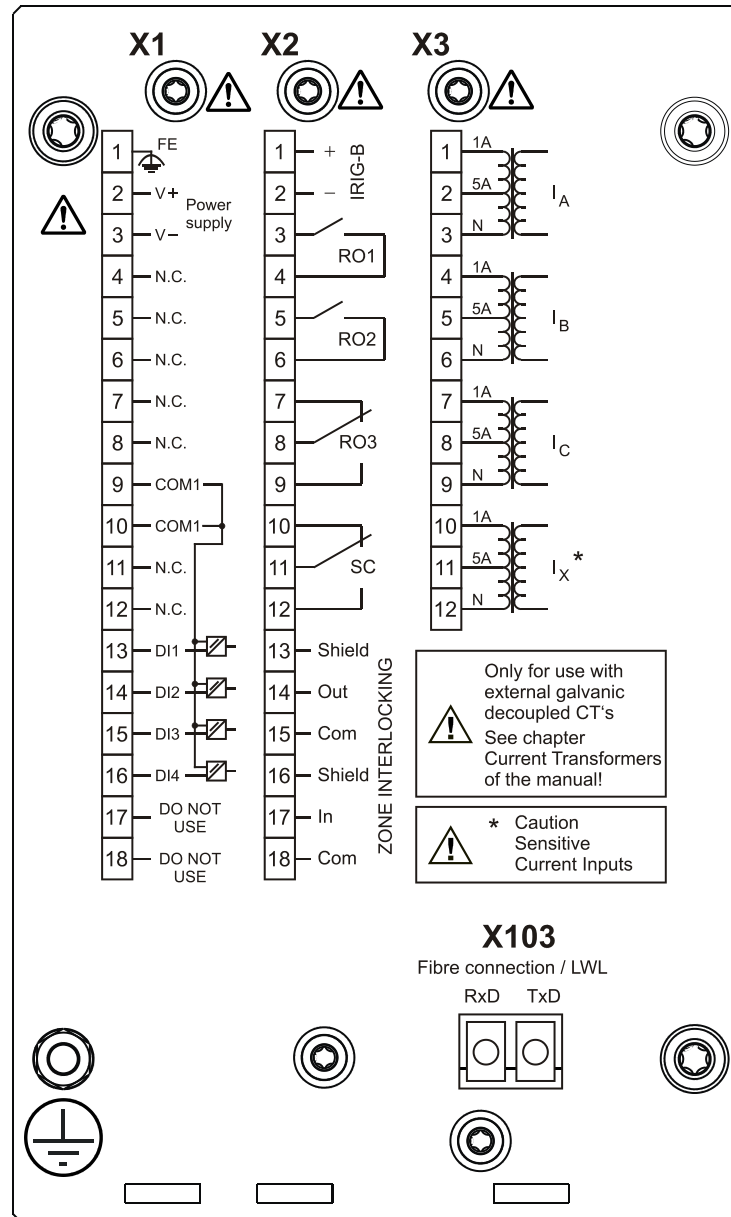

EDR-3000-2C1LA

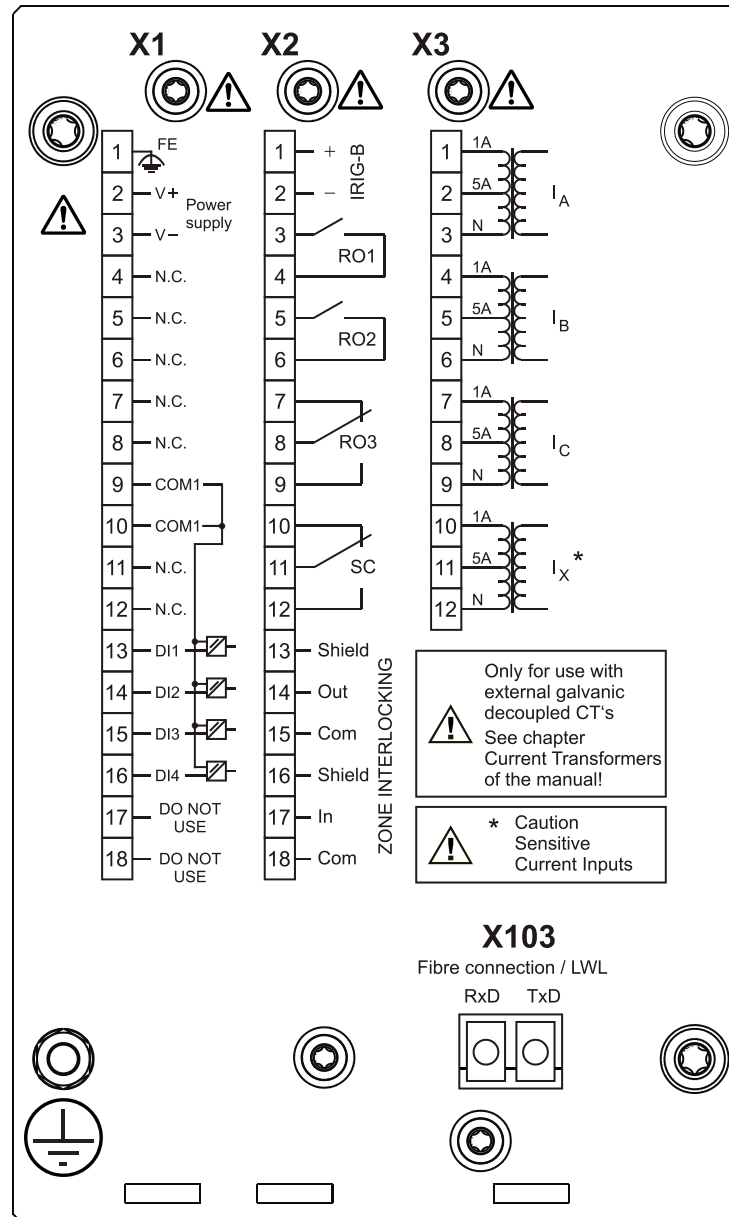

EDR-3000-2C1LB

