

NOTES:

1. HOLD ROUGH-IN DIMENSIONS ± 1/8" (3.2mm)
2. WHEN INSTALLING THIS UNIT, LOCAL, STATE OR FEDERAL CODES SHOULD BE ADHERED TO. FOR INSTALLATION HEIGHTS OTHER THAN SHOWN, DIMENSIONS MARKED (*) MUST BE ADJUSTED ACCORDINGLY.
3. ALIGN HOLES IN CHILLER SUPPORT TRAY WITH HOLES IN FRAME AND FASTEN WITH #10 SHEET METAL SCREWS.
4. REFER TO 5874 SERIES OPERATION AND MAINTENANCE MANUAL FOR PUSH BUTTON AND VALVE INSTALLATION/MAINTENANCE INSTRUCTIONS.
5. REFER TO MTGFR.LG INSTALLATION DRAWING FOR ROUGH-IN DIMENSIONS.
6. INSERT 5/16"-18 PANEL INSERTS FROM OPPOSITE SIDE AT LOCATIONS SHOWN BY DARKENED HOLES. HOLE COMBINATIONS SHOWN ARE FOR USE WITH LOW FOUNTAIN ON THE RIGHT AND THE HI FOUNTAIN ON THE LEFT. USE OPPOSITE HOLES FOR HI ON RIGHT AND LOW ON LEFT.
7. HOLE COMBINATION SHOWN BELOW IS FOR USE WITH LOW FOUNTAIN ON THE RIGHT AND HIGH FOUNTAIN ON THE LEFT. USE OPPOSITE HOLES FOR HIGH ON RIGHT AND LOW ON LEFT.
8. TO CHANGE FOUNTAIN MTG. SCREW LOCATIONS: FIRST REMOVE SCREWS AND THEN SQUEEZE CLIPS ON NUT RETAINER TO POP OUT. SNAP INTO NEW POSITIONS AND RE-ASSEMBLE SCREWS.
9. IMPORTANT: A L.H. LOW (OPTIONAL) CONFIGURATION WILL REQUIRE A DIFFERENT BACK PANEL AND THE WASTE AND SUPPLY DIMENSIONS SHOWN (*) MUST BE REVERSED.

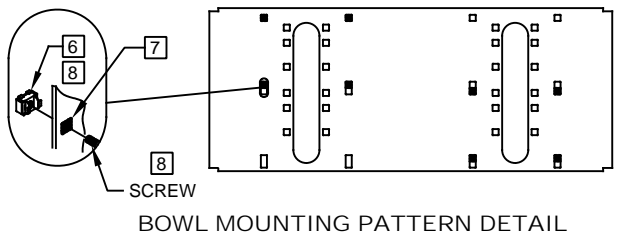
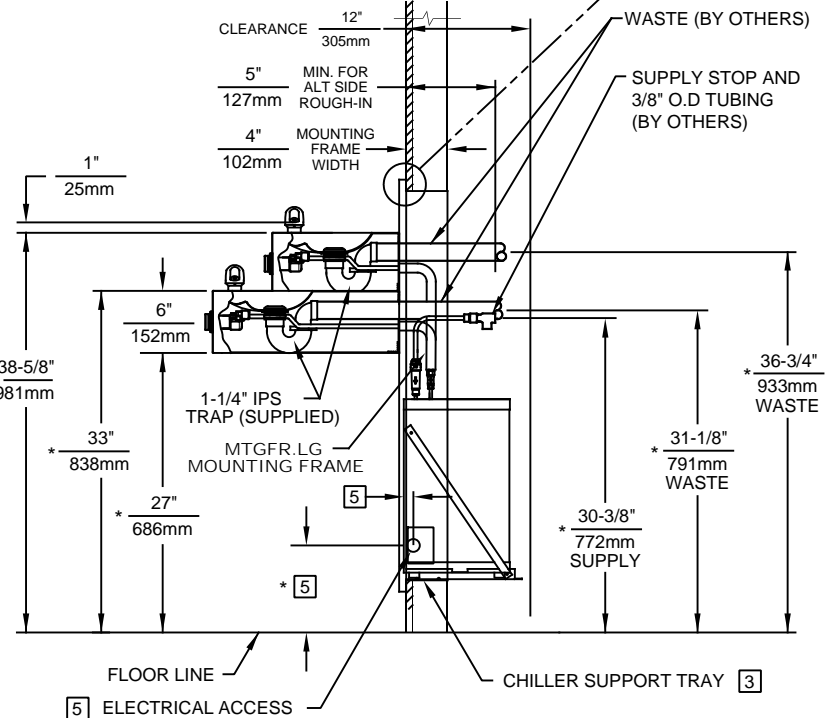
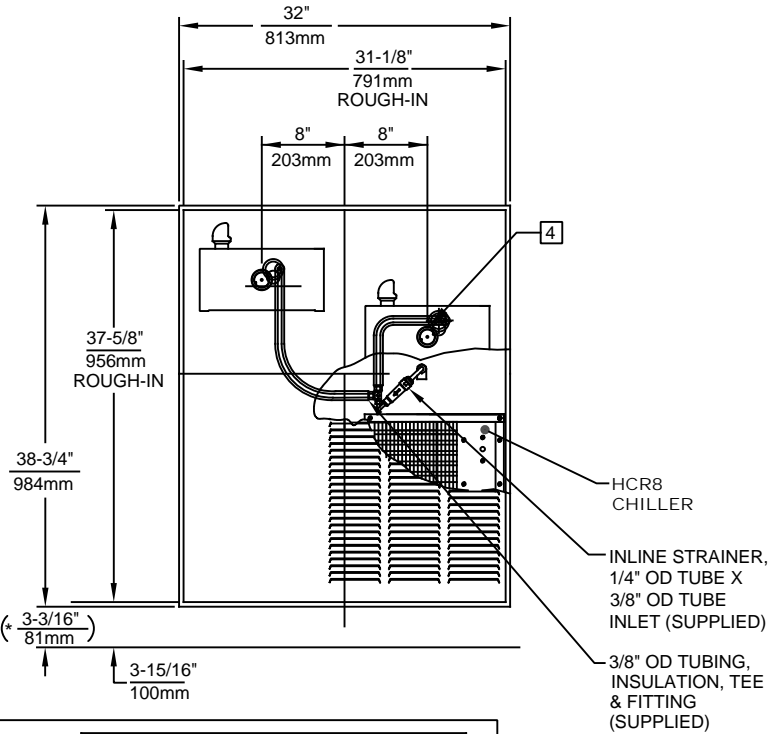
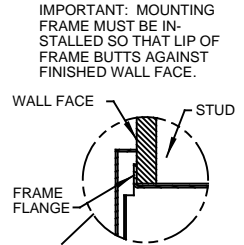
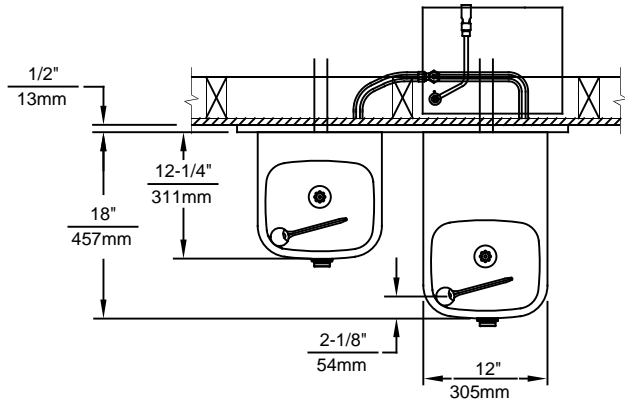

1455 KLEPPE LANE
SPARKS, NEVADA 89431
(775) 359-4712 FAX (775) 359-7424
E-MAIL: HAWS@HAWS.CO.COM
WEBSITE: WWW.HAWS.CO.COM

ECN NO. REVISED PER BY:		MODEL(S)		PART NUMBER	
ECN: 5190		JP		H1119.8	
DRAWN: F.VASQUEZ		DATE: 09-01-98		REVISION	
APPROVED: FV		DATE: 07/07/17		21	
SCALE: 1:19		DRAWING TYPE: INSTALLATION		SIZE: A SHEET 1 OF 1	