

ITEM	DESCRIPTION	PART NO.
1	STRAINER ASSEMBLY	6462
2	BACK PANEL	0004023580
3	HEAD	5703M
4	BUTTON, PUSH, FLANGED, ASSY	PBA6
5	BUTTON, PUSH, FLANGED, WITH VALVE	5874PBF
6	BOTTOM PLATE (LONG)	PBM1109
7	BOTTOM PLATE (SHORT)	PBM1105
8	MOUNTING FRAME	MTGFR.LG
9	CHILLER	HCR8-300
10	SPANNER WRENCH	0006983506
11	GRILLE	0002626651
12	TRAP	0005982900
13	VALVE REPAIR KIT	VRK5874

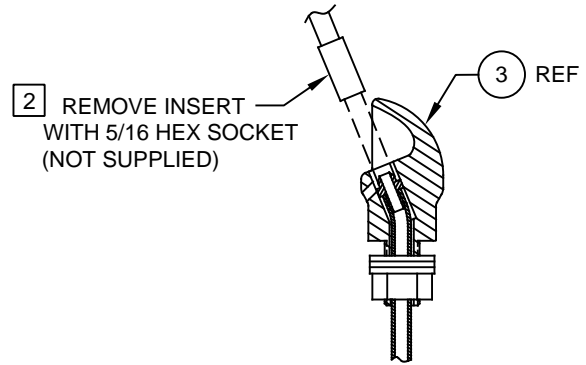

DETAIL A  
ROTATED 90° INTO VIEW

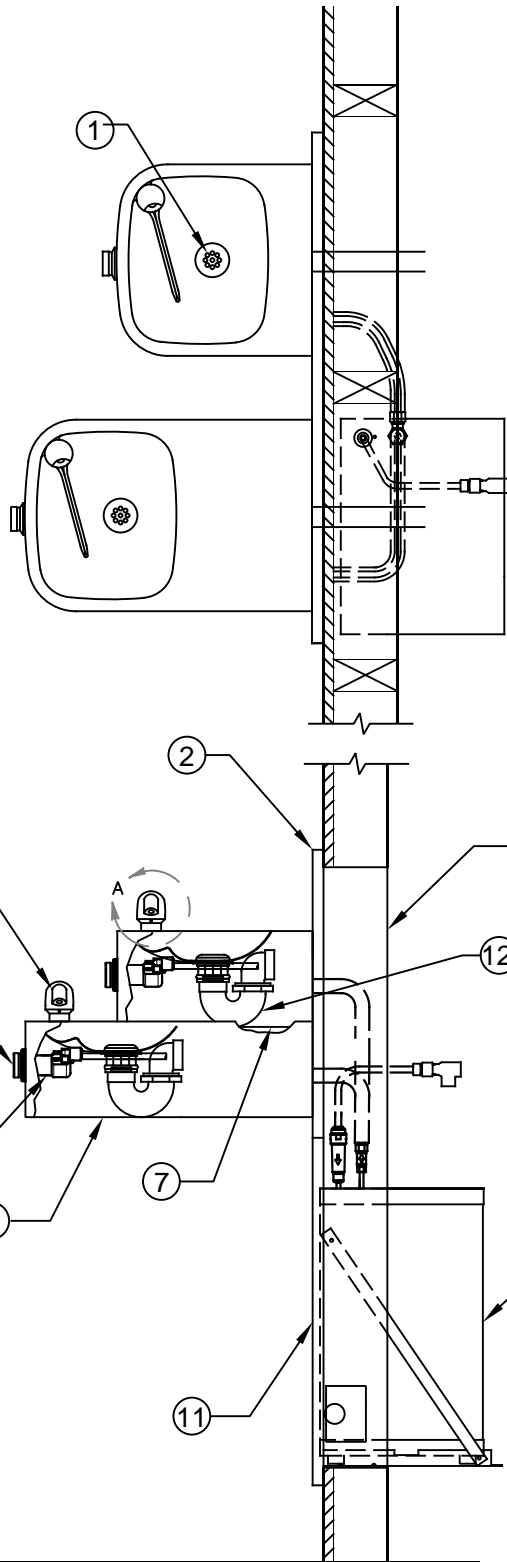
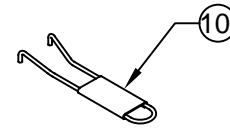

NOTES:

- 1 5874PBF (ITEM 5) INCLUDES VRK5874 CARTRIDGE ASSEMBLY (ITEM 13) AND PBA6 FLANGED PUSH BUTTON (ITEM 4).
- 2 ENSURE TUBE IS DISCONNECTED FROM PUSH BUTTON VALVE BODY PRIOR TO REMOVAL. APPLY ONE DROP OF LOCTITE 222MS TO NOZZLE THREADS PRIOR TO FASTENING BACK ONTO BUBBLER HEAD. RE-ATTACH TUBE TO VALVE.

# PARTS BREAKDOWN

WHEN ORDERING PARTS PLEASE SPECIFY MODEL NUMBER.

		<b>Haws</b> <sup>®</sup>		1455 KLEPPE LANE SPARKS, NEVADA 89431 (775) 359-4712 FAX (775) 359-7424 E-MAIL: HAWS@HAWS.CO.COM WEBSITE: WWW.HAWS.CO.COM	
				ECN NO. REVISED PER BY ECN: 5190 JP	MODEL(S) H1119.8
DRAWN F. VASQUEZ	DATE 09-04-98	CHKD VWC			
APPROVED FV	DATE 07/08/17	SCALE: 1:4	DRAWING TYPE: PARTS BREAKDOWN	SIZE: A	SHEET 1 OF 1